



FORD E40D "UPDATE HANDBOOK"

**PREVIOUS
MENU**

GO TO PAGE

INDEX

VALVE BODY AND CHECKBALL CHANGES THRU 1996	3
1989-1995 VALVE BODY CHECKBALL LOCATIONS	6
1996 VALVE BODY CHECKBALL LOCATIONS	7
EARLY 1989 CASE CHECKBALL LOCATIONS	8
LATE 1989 CASE CHECKBALL LOCATIONS	9
1990-1995 CASE CHECKBALL LOCATIONS	10
1996 CASE CHECKBALL LOCATIONS	11
SPACER PLATES AND IDENTIFICATION	16
MAIN VALVE BODY DIFFERENCES AND IDENTIFICATION	19
LOWER VALVE BODY DIFFERENCES AND IDENTIFICATION	21
CASE DIFFERENCES AND IDENTIFICATION	23
OUTPUT SHAFT CHANGES	27
OVERDRIVE SECTION FAILURE	33
4TH CLUTCH SNAP RING CHANGE	35
LOW ROLLER CLUTCH INNER RACE CHANGE	36
COOLER LINE FITTING CHANGES	37
LOW ROLLER CLUTCH ASSEMBLY CHANGE	41
OVERDRIVE SPRAG CHANGES	43
BALL BEARING CENTER SUPPORT CHANGE	48
OVERDRIVE CARRIER AND INPUT SHAFT CHANGE	55
CAST IRON OVERDRIVE CARRIER	58
DIRECT CLUTCH HOUSING CHANGE	60
SOLENOID PACK CHANGE FOR 1995 MODELS	61
FRONT PUMP CHANGE FOR 1995 MODELS	66
INTERMEDIATE SERVO PISTON CHANGE	74
SUN GEAR DIFFERENCES	77
1989-1995 VALVE BODY (EXPLODED VIEW)	78
1996 VALVE BODY (EXPLODED VIEW)	80
NEW DESIGN PUMP COVER AND STATOR SHAFT (BLOCKED COOLER)	82
REVERSE CLUTCH LIP SEALS FOR 1996	84
LARGER DESIGN LOW ROLLER CLUTCH CHANGE	88
NEW DESIGN FORWARD RING GEAR HUB AND PLANETARY	93
NEW DESIGN OVERDRIVE CLUTCH PISTON AND HOUSING	96
COOLER BY-PASS VALVE ADDED TO SOME 1997 MODELS	98
LUBE ORIFICE CUP PLUG ADDED TO 1997 MODELS	100
NEW DESIGN FRONT PUMP FOR 1997-1998 MODELS	102
NEW DESIGN 6 PINION FORWARD AND REAR PLANETARY CARRIERS	110
NEW DESIGN SUN SHELL	112
INTERMEDIATE DIODE FREEWHEEL FAILURE	116
INCREASED OVERDRIVE CLUTCH CAPACITY	118

**AUTOMATIC TRANSMISSION SERVICE GROUP
9200 S. DADELAND BLVD. SUITE 720
MIAMI, FLORIDA 33156
(305) 670-4161**

Copyright © ATSG 2004



INTRODUCTION FORD E4OD "UPDATE HANDBOOK"

Since the introduction of the E4OD transmission in model year 1989, there have been many engineering changes to improve Pleasability, Reliability, and Durability concerns. These changes have affected most every part used in the E4OD transmission. This *"UPDATE HANDBOOK"* will explain each change, the reason for the change, and any parts interchangeability problems created by the change, along with any part numbers to update your transmission.

The information and part numbers contained in this booklet have been carefully compiled from industry sources known for their reliability, but ATSG does not guarantee its accuracy.

**ROBERT D. CHERRNAY
TECHNICAL DIRECTOR**

**WAYNE COLONNA
TECHNICAL SUPERVISOR**

**PETER LUBAN
TECHNICAL CONSULTANT**

**GREGORY LIPNICK
TECHNICAL CONSULTANT**

**DAVID CHALKER
TECHNICAL CONSULTANT**

**DALE ENGLAND
FIELD SERVICE CONSULTANT**

**ED KRUSE
TECHNICAL CONSULTANT**

**JIM DIAL
TECHNICAL CONSULTANT**

**JERRY GOTT
TECHNICAL CONSULTANT**

**ARSENIO RIVERA
TECHNICAL CONSULTANT**

AUTOMATIC TRANSMISSION SERVICE GROUP
9200 S. DADELAND BLVD. SUITE 720
MIAMI, FLORIDA 33156
(305) 670-4161

Copyright © ATSG 1996



**FORD E40D
VALVE BODY, SPACER PLATE, SPACER PLATE GASKETS,
CHECKBALL LOCATIONS, AND CASE CHANGES,
FOR THE 1996 MODEL YEAR**

CHANGE: Beginning in mid-1989 Ford Motor Co. changed the checkball locations in the case, and in 1990 changed the case checkball locations again. Beginning in 1996, both the valve body and case checkball locations change once again. These changes have created confusion in the field.

REASON: Pleaseability, Reliability, and Durability concerns.

PARTS AFFECTED:

(1) **VALVE BODY CHECKBALL LOCATIONS** - Have remained the same for 1989 thru 1995 model years, with **TWO** 5/16" rubber checkballs, and their locations are shown in Figure 1. Beginning in the 1996 model year there are **FIVE** checkballs in the main valve body and their locations are shown in Figure 2. Notice that there are two 5/16" rubber balls and three 1/4" rubber balls. The 1/4" rubber balls are green in color (See Figure 2).

(2) **CASE CHECKBALL LOCATIONS** - Have now changed **three times** since the introduction in 1989, as listed below.

Early 1989 Models - Requires **Fourteen** 5/16" checkballs in the case, in the locations shown in Figure 3, and uses a 1/4" steel ball for the EPC blow-off, and location shown in Figure 3.

Late 1989 Models - Requires **Ten** 5/16" rubber checkballs, and **One** 5/16" diameter steel checkball, for a total of **Eleven**, in the locations shown in Figure 4, and uses a 1/4" steel ball for the EPC blow-off, and the location is shown in Figure 4.

All 1990-1995 Models - Requires **Nine** 5/16" rubber checkballs in the case, in the locations shown in Figure 5, and uses a 1/4" steel ball for the EPC blow-off, and the location is shown in Figure 5. Beginning in 1991 there is an added Intermediate Accumulator Regulator Filter Assembly, and the location in the case is shown in Figure 5.

All 1996-UP Models - Requires **Eight** 5/16" rubber checkballs in the case, in the locations shown in Figure 6, and uses a 1/4" steel ball for the EPC blow-off, and the location is shown in Figure 6.

(3) **SPACER PLATE GASKETS** - Have changed twice since the introduction in 1989.

1989 Models Only - Require the Spacer Plate Gaskets with solenoid feed hole (Marked X) in the location shown in Figure 8, and the gaskets have **No I.D.** stripes on either gasket.

90-95 Models Only - Require the Spacer Plate Gaskets with solenoid feed hole (Marked X) in the location shown in Figure 9, and both gaskets have **Yellow I.D.** stripes

96-UP Models Only - Require the Spacer Plate Gaskets with **Green I.D.** stripes on both gaskets. These gaskets have a multitude of hole location differences, as shown in Figure 10.

Continued on next Page.



Technical Service Information

- (4) **MAIN VALVE BODY SPACER PLATE**- Has changed twice since the introduction in 1989.
1989 Models Only - Requires the Spacer Plate with the solenoid feed hole in the location shown in Figure 11, and has two "Square" notches for identification

90-95 Models Only - Requires the Spacer Plate with the solenoid feed hole in the location shown in Figure 12, and has two "Half Moon" notches for identification. Note; Some models have two "V" notches with one "Half Moon" notch between them for identification.

1996-UP Models Only - Requires the Spacer Plate with the three "V" notches for identification as shown in Figure 13, and has a multitude of hole location changes.

- (5) **MAIN VALVE BODY** - Has changed twice since the introduction in 1989 as listed below.
1989 Models Only - Can be identified by the differences in the worm track area at the 1-2 shift valve, as shown inside the circles in Figure 14. The best, and most accurate method to identify the valve body, is the rough forging number cast into the valve body in the location shown in Figures 1 and 2.

90-95 Models Only - Can be identified by the differences in the worm track area at the 1-2 shift valve, as shown inside the circles in Figure 14. The best, and most accurate method to identify the valve body, is the rough forging number cast into the valve body in the location shown in Figures 1 and 2.

1996-UP Models Only - Has a multitude of worm track location differences from the previous models, as shown in Figure 15. The best and most accurate method to identify the valve body, is the rough forging number cast into the valve body in location shown in Figures 1 and 2.

- (6) **LOWER VALVE BODY SPACER PLATE** - Can be identified by the diameter of the feed hole in the location shown in Figure 16. For 1989 models the hole diameter is .312", and for 90-95 models the hole diameter is .055".
The 1996-Up models have three small holes in this location, as shown in Figure 16, and a multitude of hole location differences to accommodate the added valve body checkballs.

- (7) **LOWER VALVE BODY** - The engagement control valve retaining clip on 1989 models, was replaced by a bore plug and new design clip on the 90-95 models, which also changed the worm track configuration in that area, as shown inside the circles in Figure 17.
The 1996-Up models have a multitude of worm track location differences than the previous models, to accommodate the added valve body checkballs, as shown in Figure 17. The best, and most accurate method of identification is the rough forging number cast into the lower valve body using the formula in Figures 1 and 2.

Continued on next Page.



Technical Service Information

INTERCHANGEABILITY:

- (1) The 1989 Main Spacer Plate **MUST** be used on 1989 case, with 1989 checkball locations, 1989 valve body gaskets (No Stripe), and 1989 Main Valve Body.
- (2) The 1989 Main Valve Body can be used on 90-95 models, but the 90-95 Main Valve Body **MUST** be used on 90-95 models.
- (3) The Lower Valve Body and spacer plates should also be kept together, large (.312") hole with 1989 models, and small (.055") hole with 90-95 models.
- (4) None of the 1996 design level parts will interchange with previous models.

SERVICE INFORMATION:

Main Valve Body Spacer Plate (1989 Models)	E9TZ-7A008-A
Main Valve Body Spacer Plate (90-95 Models)	F5TZ-7A008-A
Main Valve Body Spacer Plate (1996 Models)	F6TZ-7A008-B
Spacer Plate to Case Gasket (1989 Models)	E9TZ-7C155-A
Spacer Plate to Case Gasket (90-95 Models)	F5TZ-7C155-A
Spacer Plate to Case Gasket (1996 Models)	F6TZ-7C155-A
Valve Body to Spacer Plate Gasket (1989 Models)	E9TZ-7D100-A
Valve Body to Spacer Plate Gasket (90-95 Models)	F5TZ-7D100-A
Valve Body to Spacer Plate Gasket (1996 Models)	F6TZ-7D100-A
Intermediate Accumulator Regulator Filter Assembly (91-96 Models)	F1TZ-7H194-A
EPC Blow-Off Spring (All Models)	E9TZ-7D017-A

FORD E4OD
1989-1995 VALVE BODY CHECKBALL LOCATIONS
TWO 5/16" RUBBER BALLS - ALL MODELS

TYPICAL ROUGH
 FORGING NUMBER
 RF-F0TP-7A092-BA

THE TWO DIGITS ABOVE THAT ARE
 UNDERLINED INDICATE MODEL YEAR

E9 = 1989
F0 = 1990
F1 = 1991
F2 = 1992
F3 = 1993
F4 = 1994
F5 = 1995
F6 = 1996

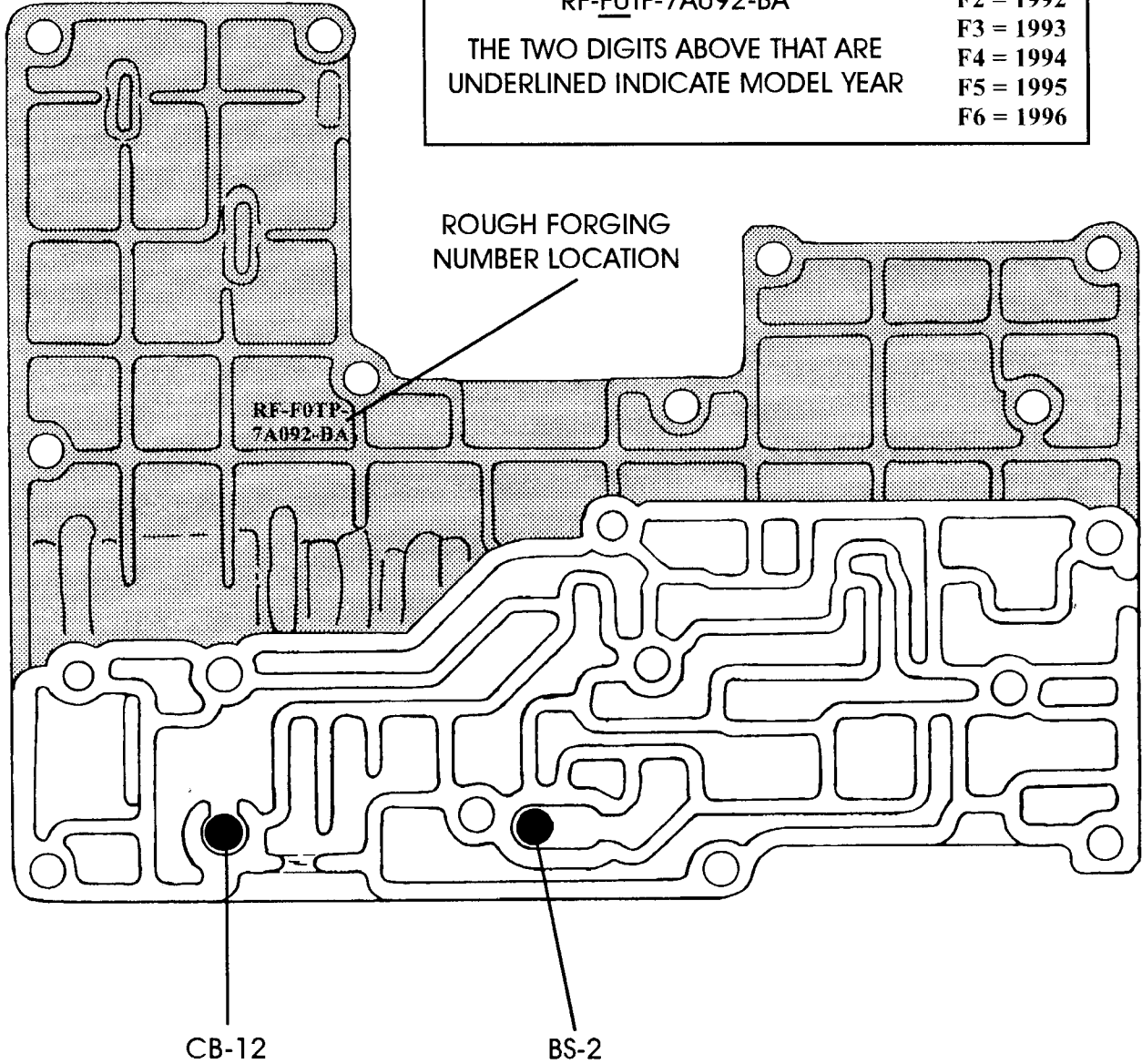


Figure 1

FORD E4OD

1996 VALVE BODY CHECKBALL LOCATIONS
REQUIRES THREE 1/4" RUBBER BALLS,
AND TWO 5/16" RUBBER BALLS

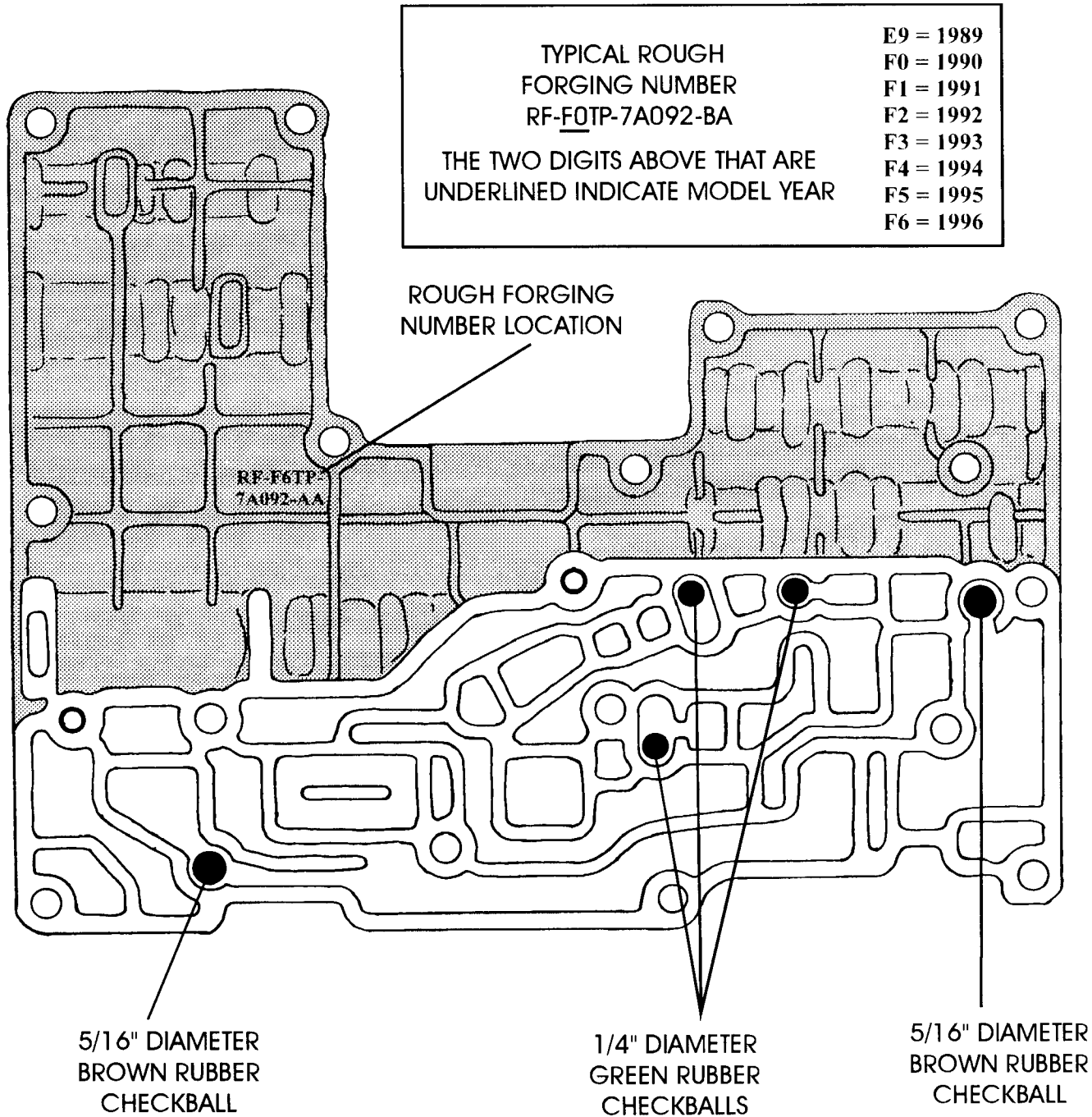


Figure 2

FORD E40D
EARLY 1989 CHECKBALL LOCATIONS
FOURTEEN (5/16") RUBBER BALLS IN CASE

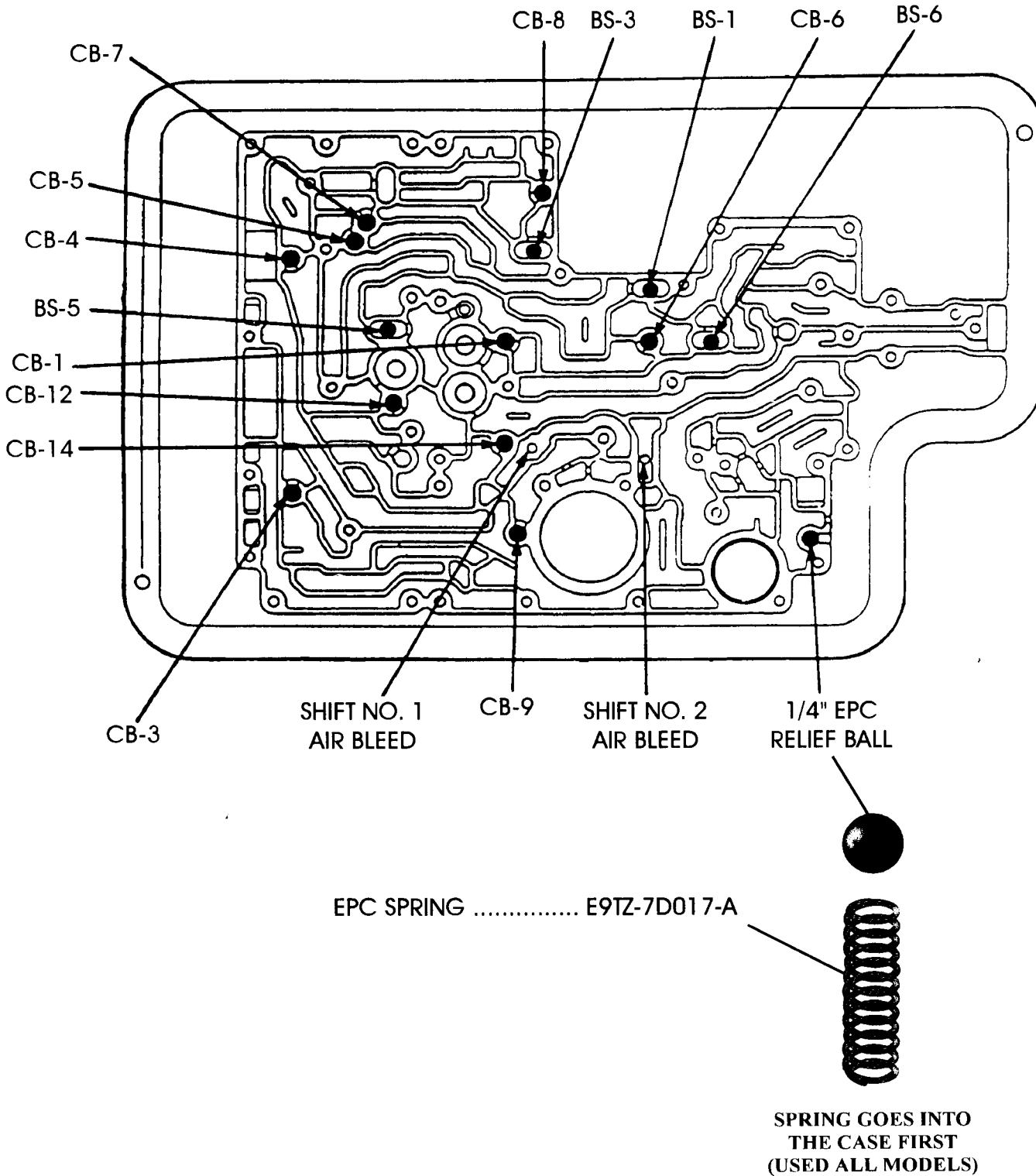


Figure 3
AUTOMATIC TRANSMISSION SERVICE GROUP

FORD E4OD

LATE 1989 CHECKBALL LOCATIONS
REQUIRES TEN (5/16") RUBBER BALLS AND
ONE 5/16" STEEL BALL IN CASE

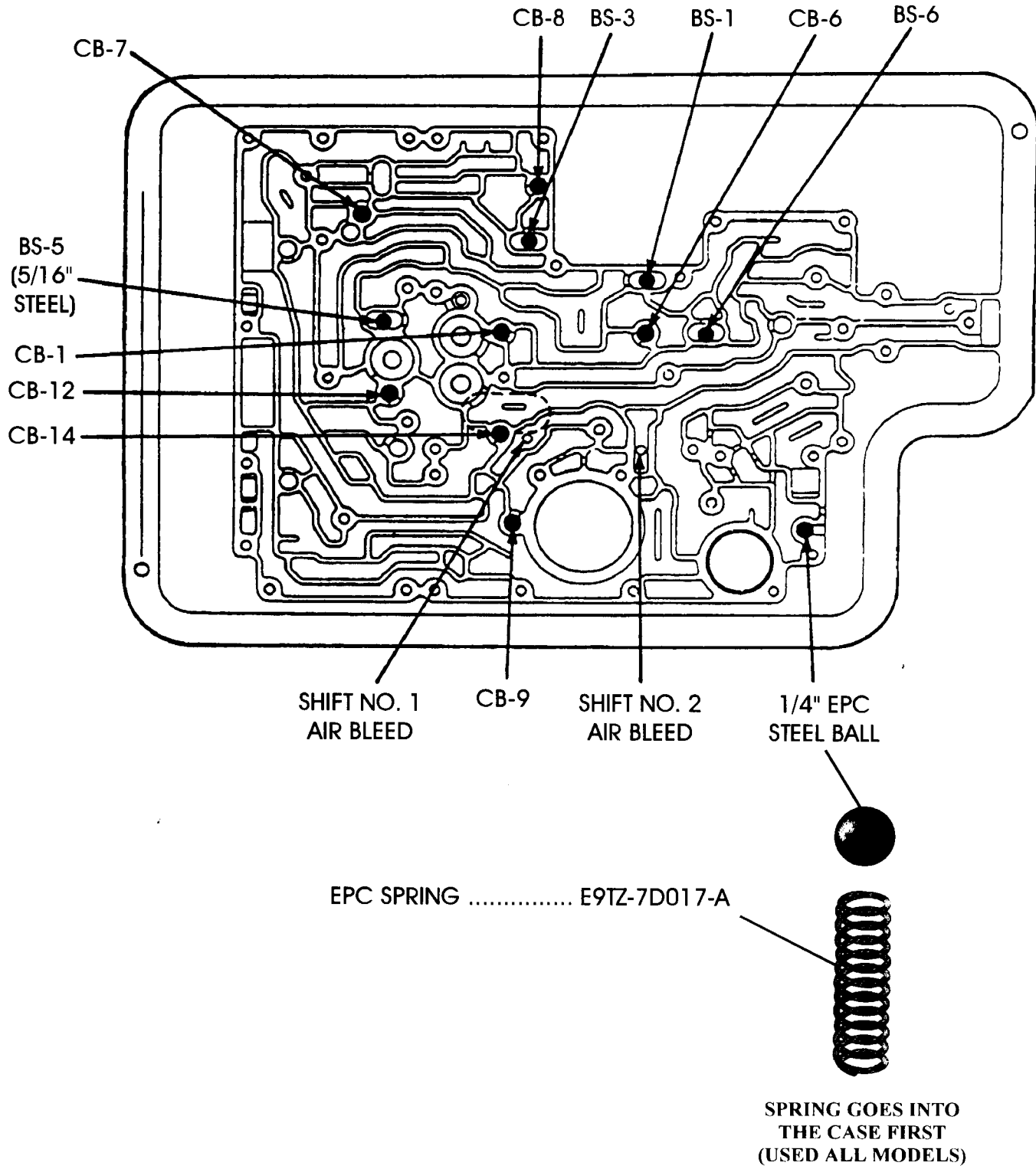


Figure 4

AUTOMATIC TRANSMISSION SERVICE GROUP

FORD E4OD
1990 - 1995 CHECKBALL LOCATIONS
REQUIRES NINE (5/16") RUBBER BALLS IN CASE

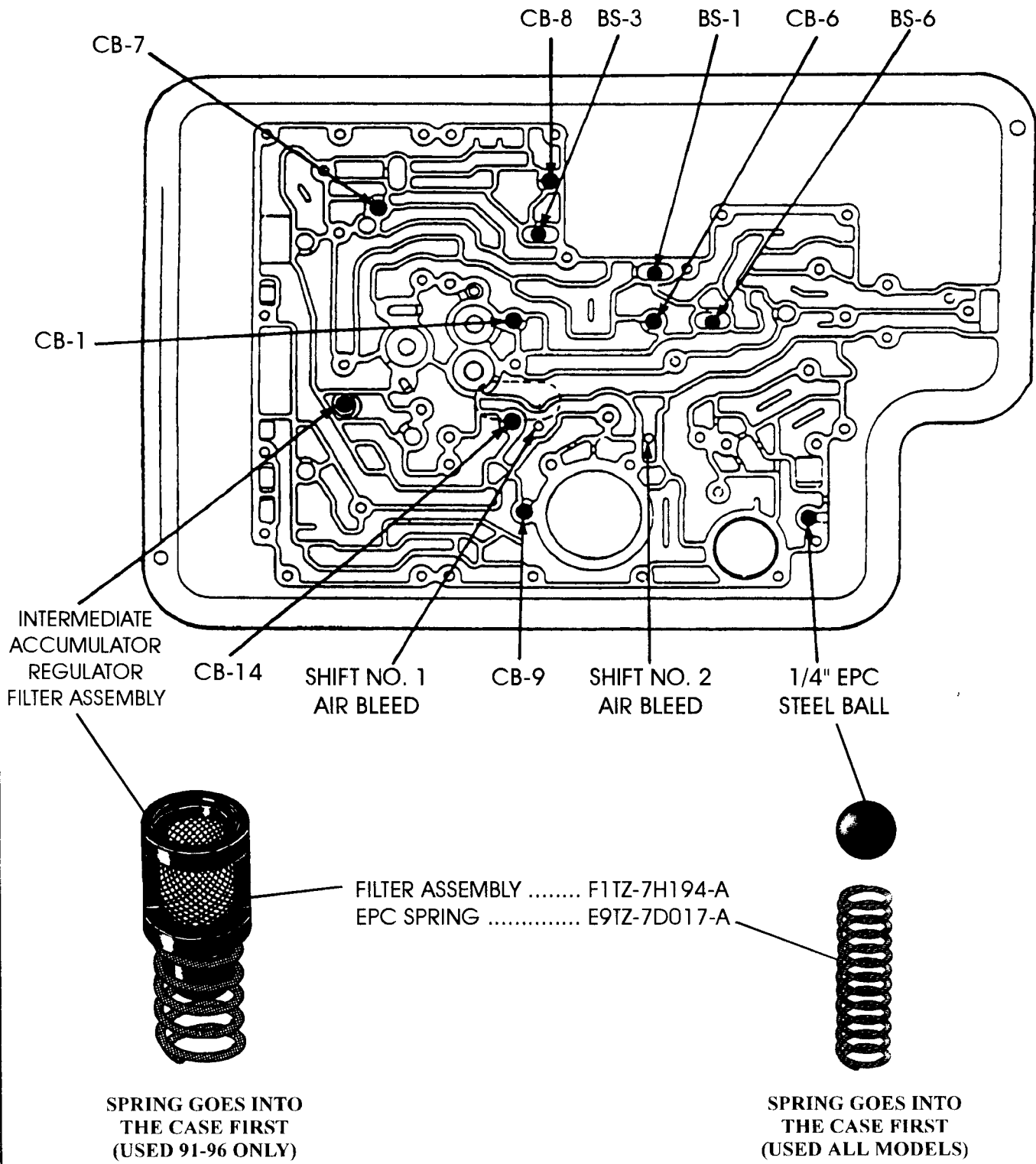


Figure 5

AUTOMATIC TRANSMISSION SERVICE GROUP

FORD E4OD
1996 CASE CHECKBALL LOCATIONS
REQUIRES EIGHT (5/16") RUBBER BALLS

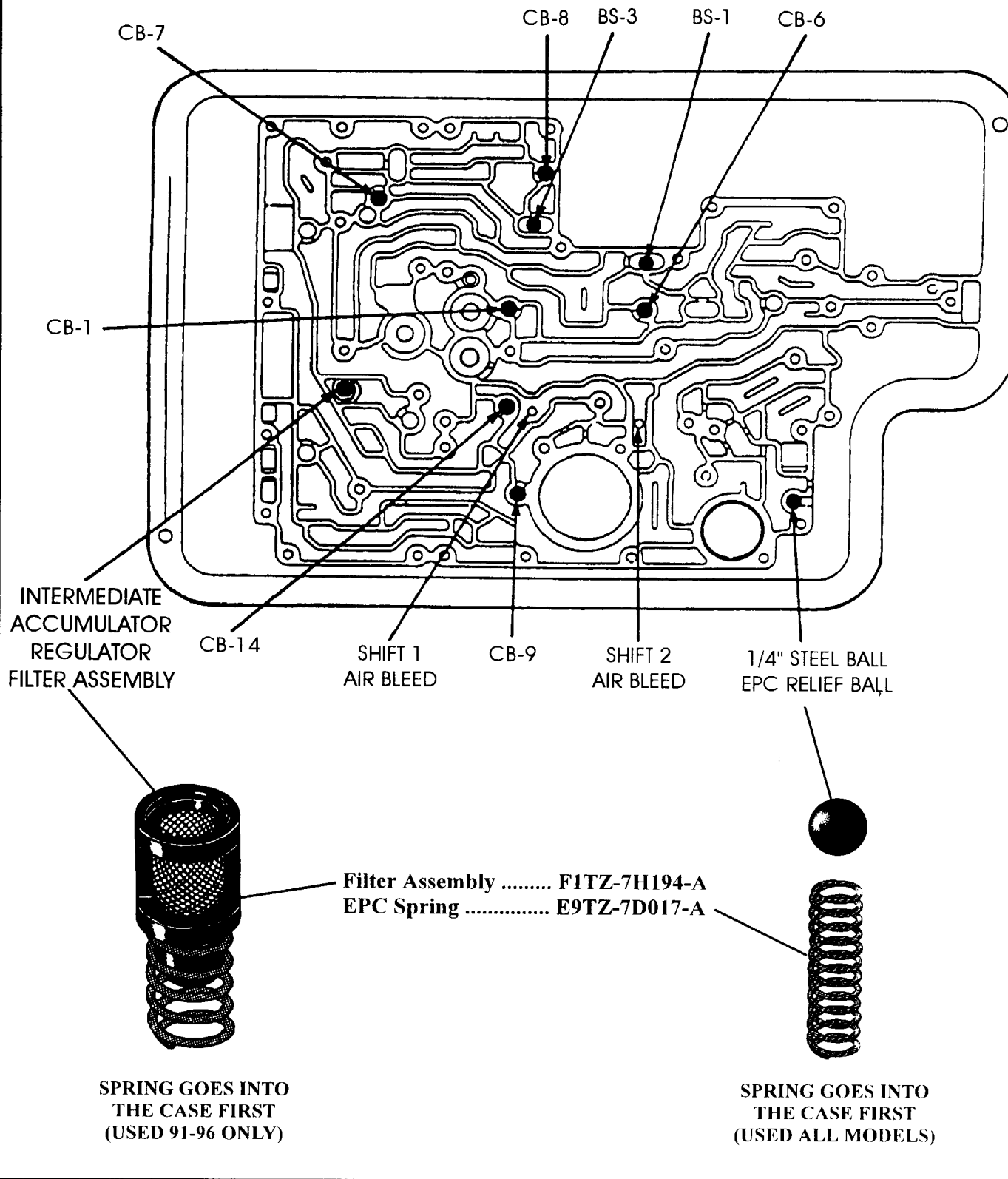


Figure 6

AUTOMATIC TRANSMISSION SERVICE GROUP

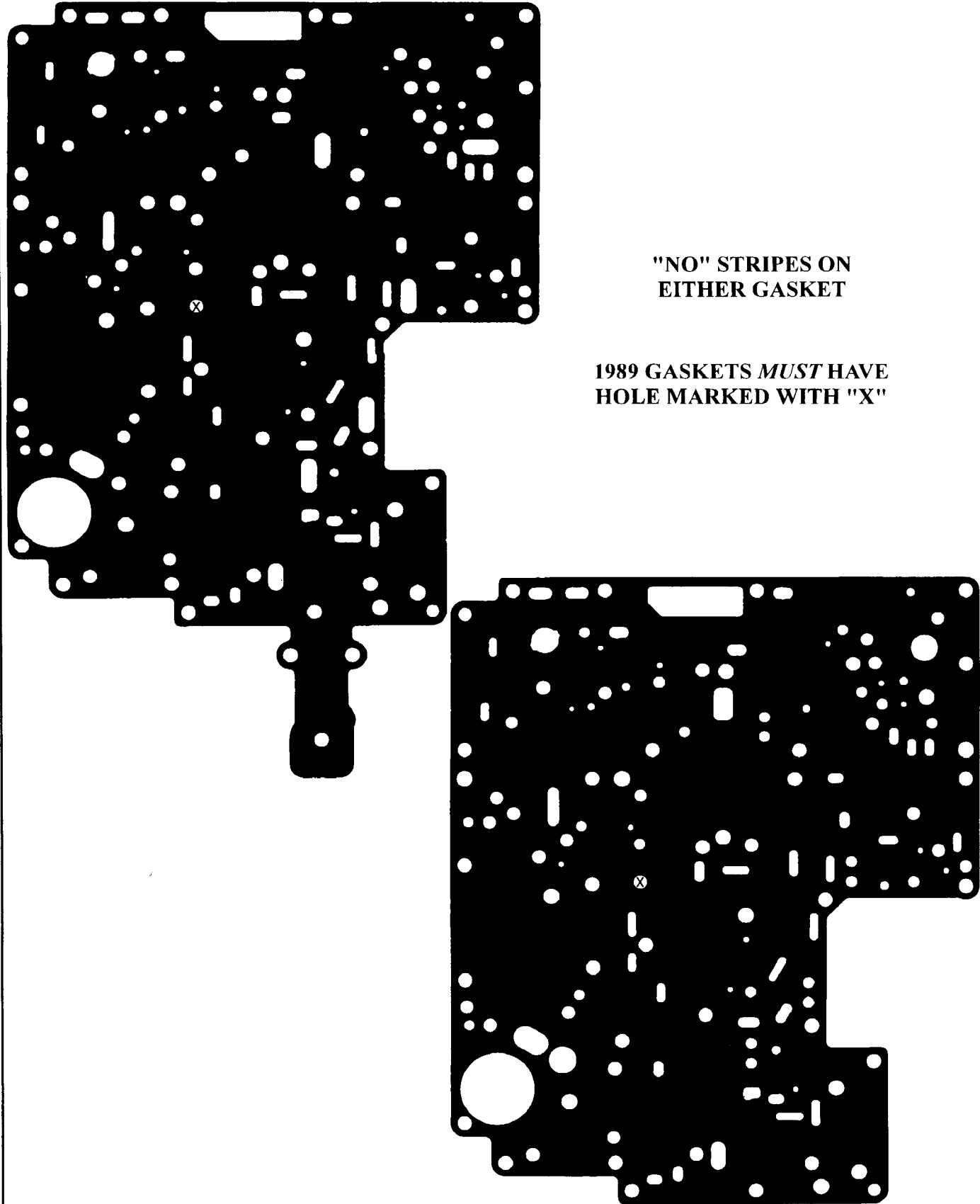


Technical Service Information

	USAGE CHART		
	EARLY 89	LATE 89	90 - 95
CB-1: Feeds reverse flow through 4-3-2 shift timing valve.	X (CASE)	X (CASE)	X (CASE)
CB-3: Bypasses intermediate accumulator plunger feed orifice during 2-1.	X (CASE)		
CB-4: Bypasses overdrive accumulator plunger feed orifice during 4-3.	X (CASE)		
CB-5: Bypasses direct accumulator plunger feed orifice during 3-2.	X (CASE)		
CB-6: Forces direct clutch to exhaust through orifice during 3-2 downshift.	X (CASE)	X (CASE)	X (CASE)
CB-7: Forces overdrive clutch to exhaust through an orifice during 4-3 downshift.	X (CASE)	X (CASE)	X (CASE)
CB-8: Forces coast clutch feed oil through orifice for 4-3 downshift and manual 1 or 2 pull-ins while allowing free exhaust.	X (CASE)	X (CASE)	X (CASE)
CB-9: Forces band servo apply pressure through an orifice while bypassing the orifice on exhaust.	X (CASE)	X (CASE)	X (CASE)
CB-12: Facilitates fast exhaust of direct clutch when coming out of reverse.	X (CASE)	X (CASE)	
CB-13: Forces forward engagement pressure through orifice while allowing free exhaust.	X (V.B.)	X (V.B.)	X (V.B.)
CB-14: Forces intermediate clutch to exhaust through orifice during 2-1 downshift.	X (CASE)	X (CASE)	X (CASE)
BS-1: Separates manual 2 flow and reverse flow to the 4-3-2 timing valve and the coast clutch shift valve.	X (CASE)	X (CASE)	X (CASE)
BS-2: Separates manual 2 flow and solenoid 2 flow into the 1-2 manual transition valve which supplies flow to prevent 1-2 shift valve from shifting.	X (V.B.)	X (V.B.)	X (V.B.)
BS-3: Separates solenoid 4 flow from either the Man. 2 flow or the reverse flow which shifts the coast clutch shift valve.	X (CASE)	X (CASE)	X (CASE)
BS-5: Separates reverse flow and direct accumulator flow into the direct clutch.	X (CASE)	X (CASE)	
BS-6: Separates two and reverse flow at low reverse modulator valve.	X (CASE)	X (CASE)	X (CASE) ELIM. 1996

Figure 7

AUTOMATIC TRANSMISSION SERVICE GROUP

1989 ONLY VALVE BODY GASKETS

**"NO" STRIPES ON
EITHER GASKET**

**1989 GASKETS *MUST* HAVE
HOLE MARKED WITH "X"**

Figure 8

AUTOMATIC TRANSMISSION SERVICE GROUP

1990-1995 ONLY VALVE BODY GASKETS

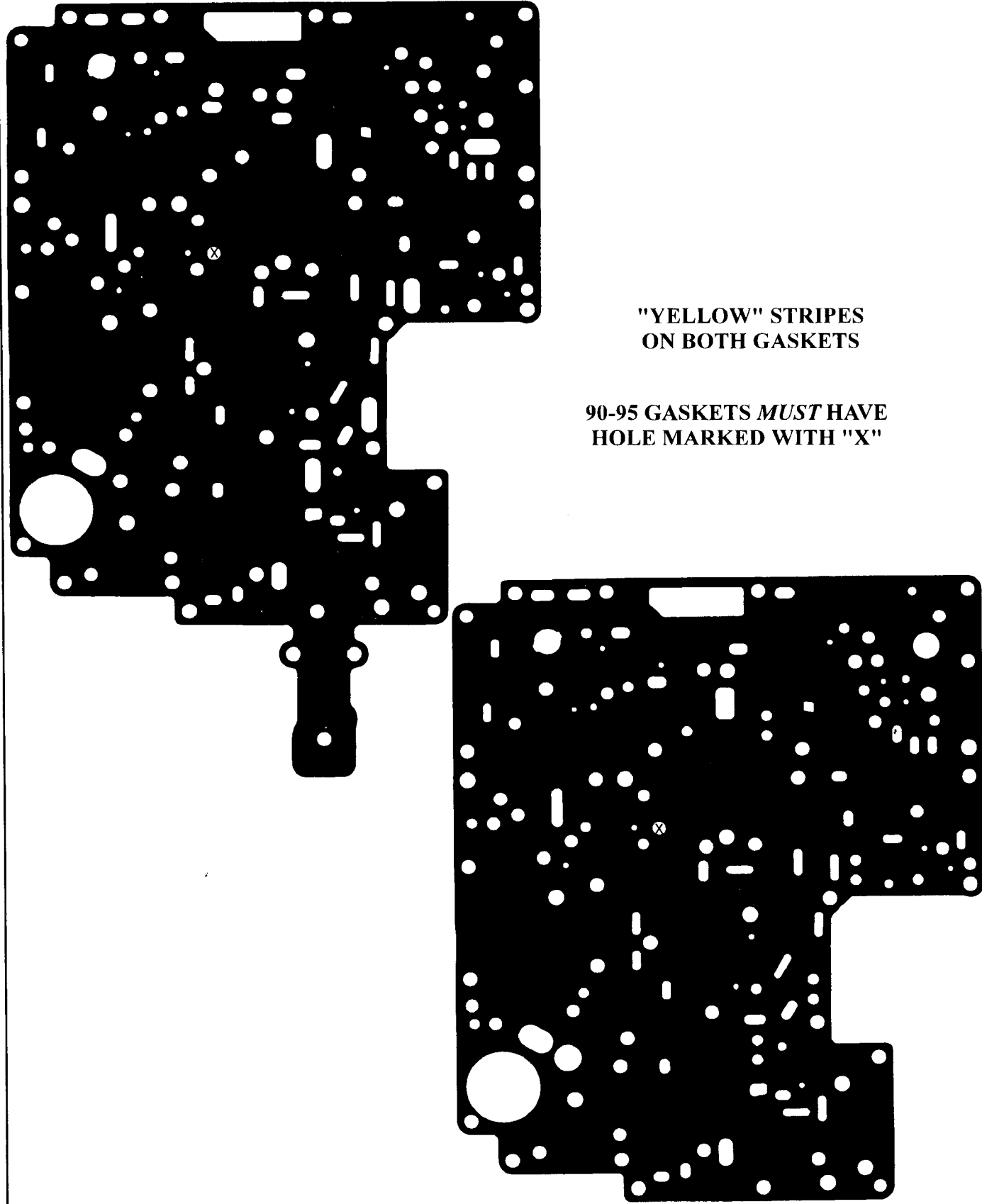
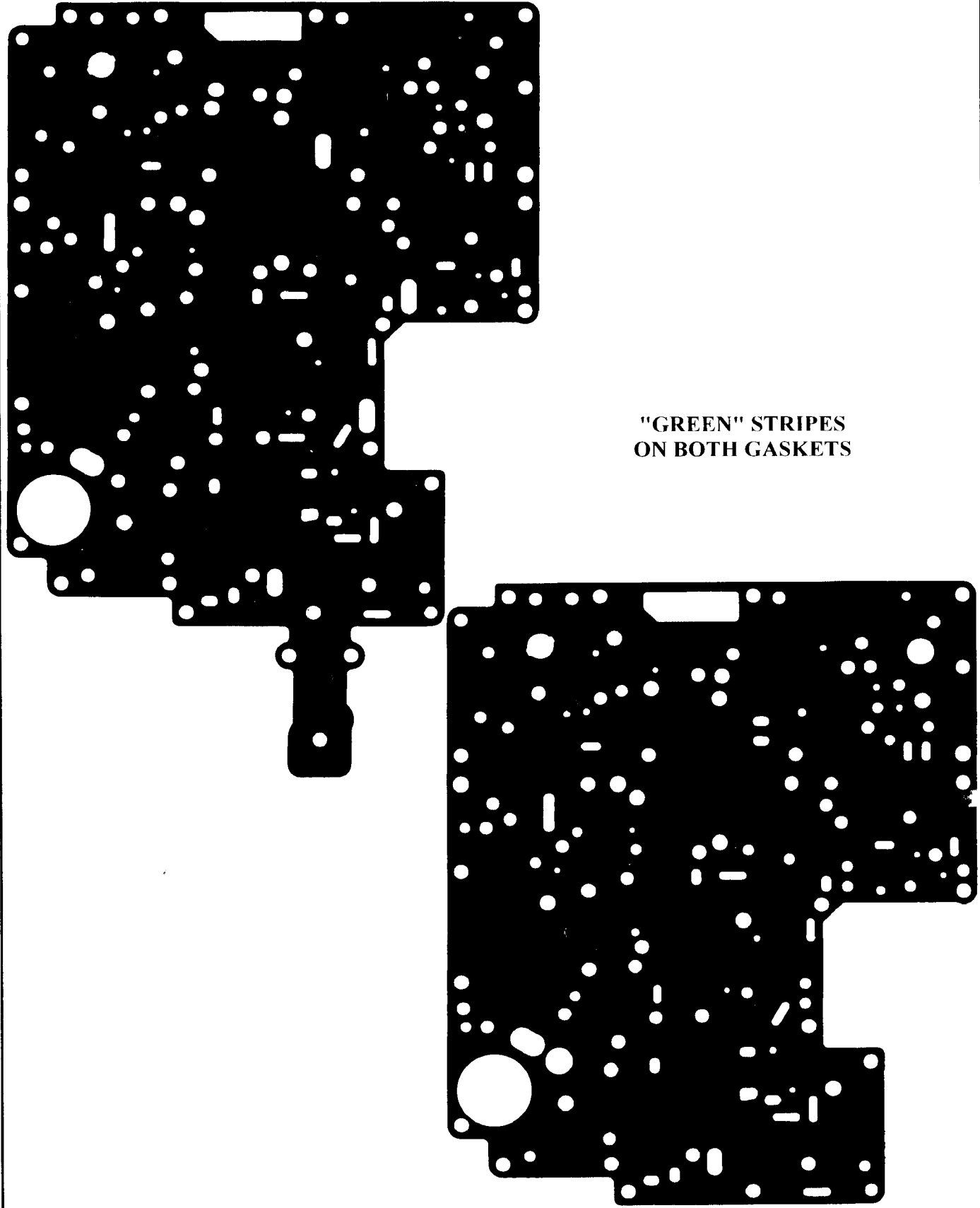


Figure 9

AUTOMATIC TRANSMISSION SERVICE GROUP

1996-UP ONLY VALVE BODY GASKETS



**"GREEN" STRIPES
ON BOTH GASKETS**

Figure 10

**1989 ONLY SPACER PLATE
PART NUMBER E9TZ-7A008-A**

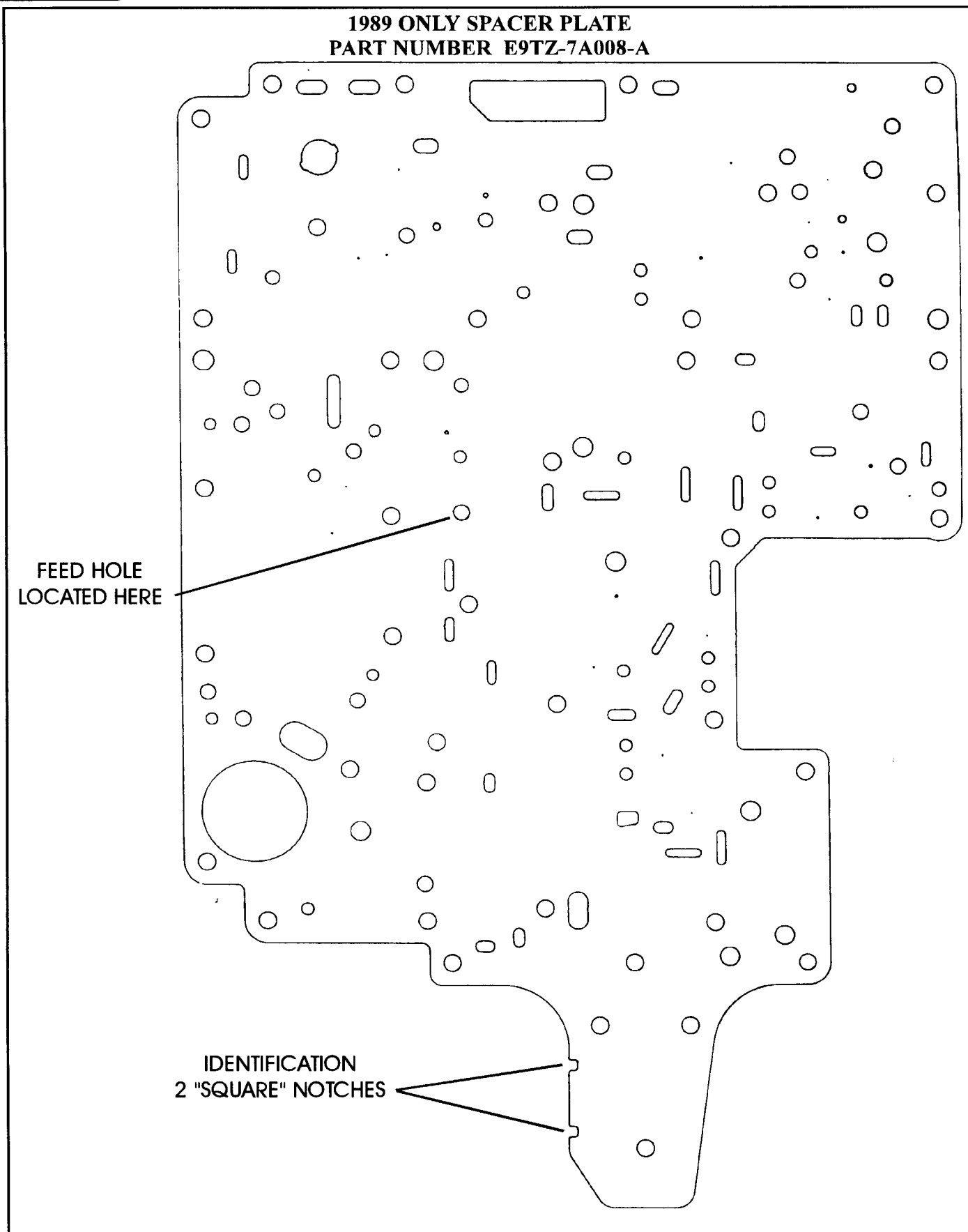


Figure 11

AUTOMATIC TRANSMISSION SERVICE GROUP

**1990-1995 ONLY SPACER PLATE
PART NUMBER F5TZ-7A008-A**

FEED HOLE
LOCATED HERE

IDENTIFICATION
2 "HALF MOON" NOTCHES

*SOME 95 MODELS HAVE 2 "V" NOTCHES
AND 1 HALF MOON INBETWEEN THEM
FOR IDENTIFICATION*

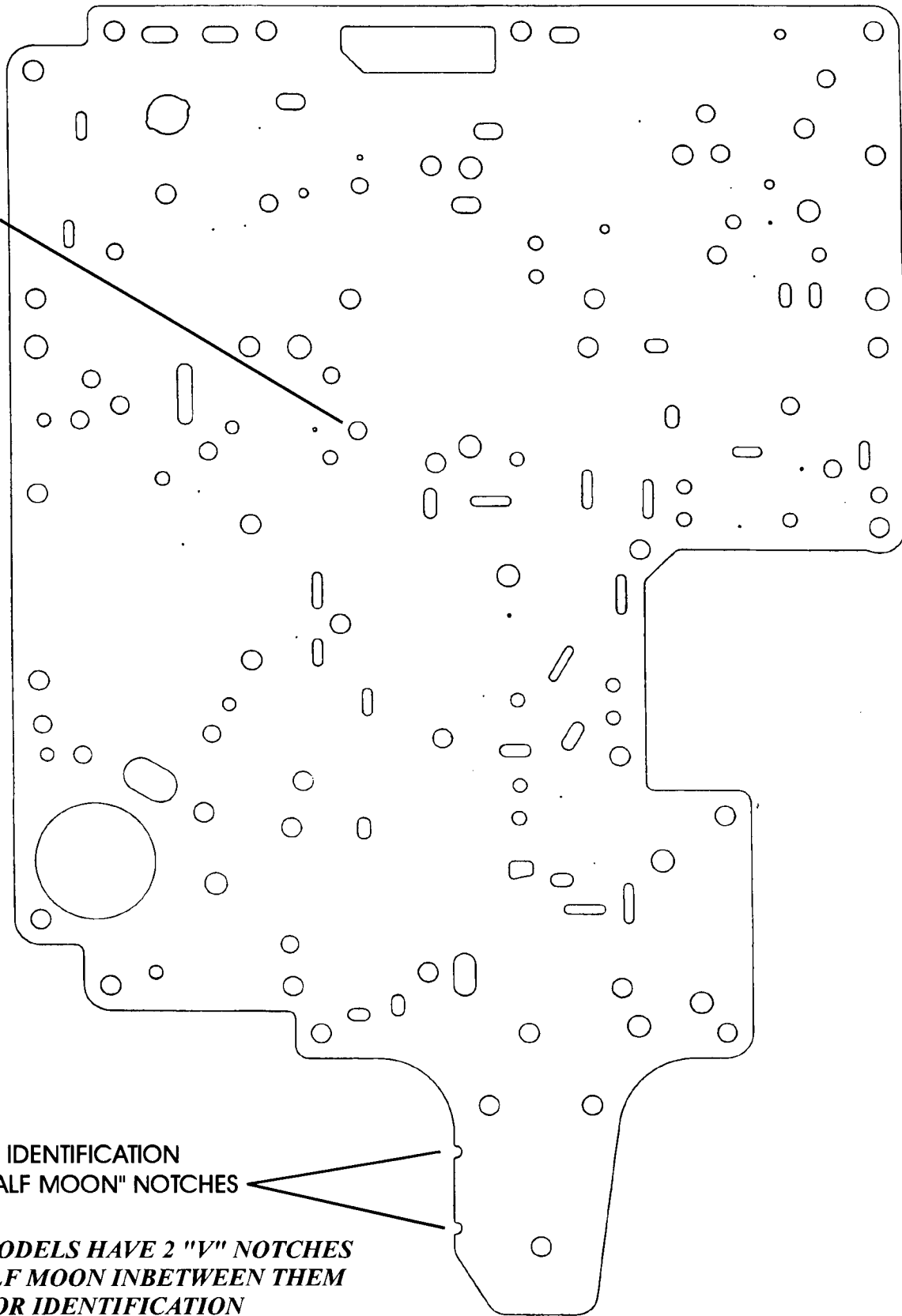


Figure 12

AUTOMATIC TRANSMISSION SERVICE GROUP

**1996-UP ONLY SPACER PLATE
PART NUMBER F6TZ-7A008-B**

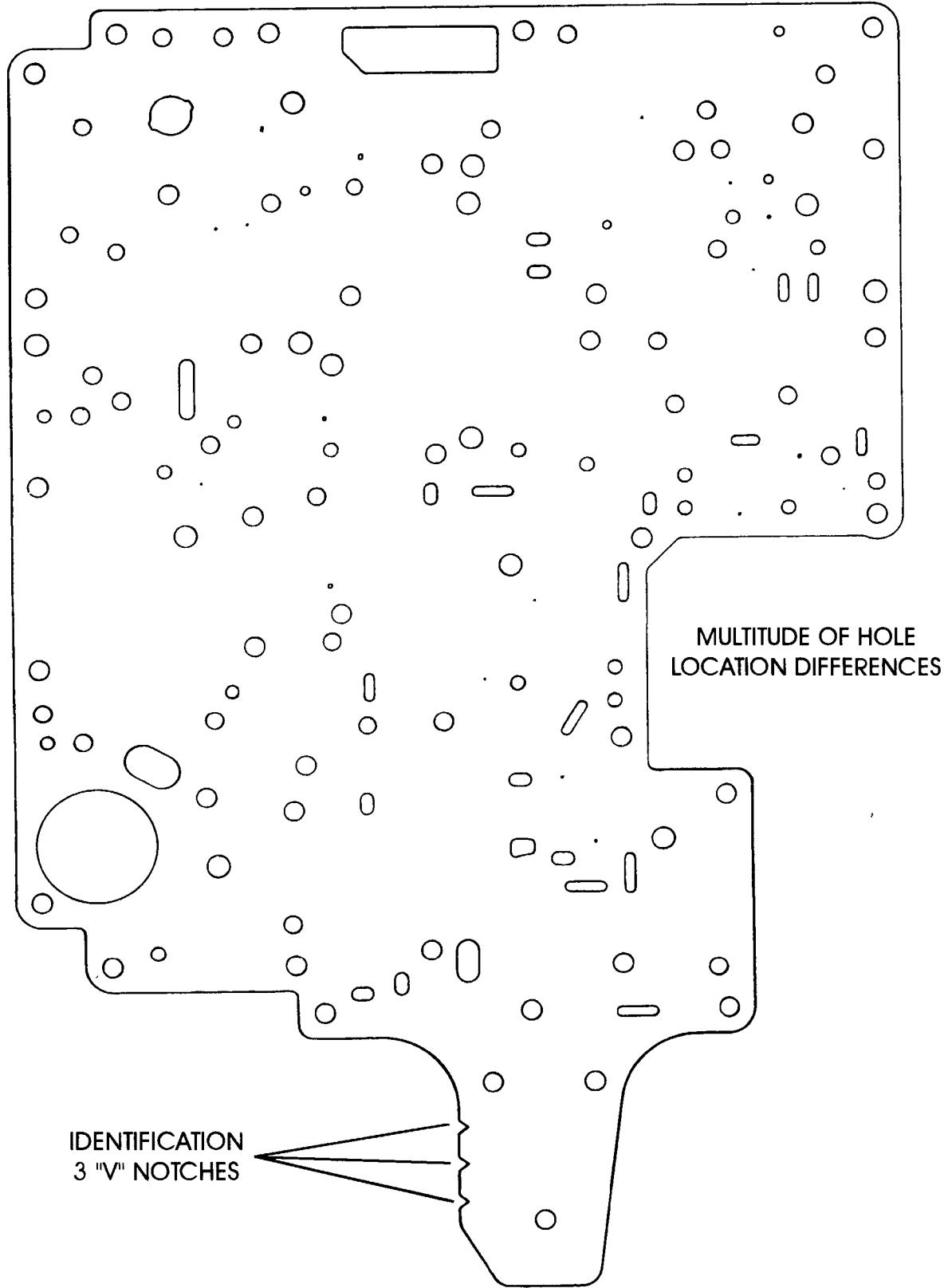
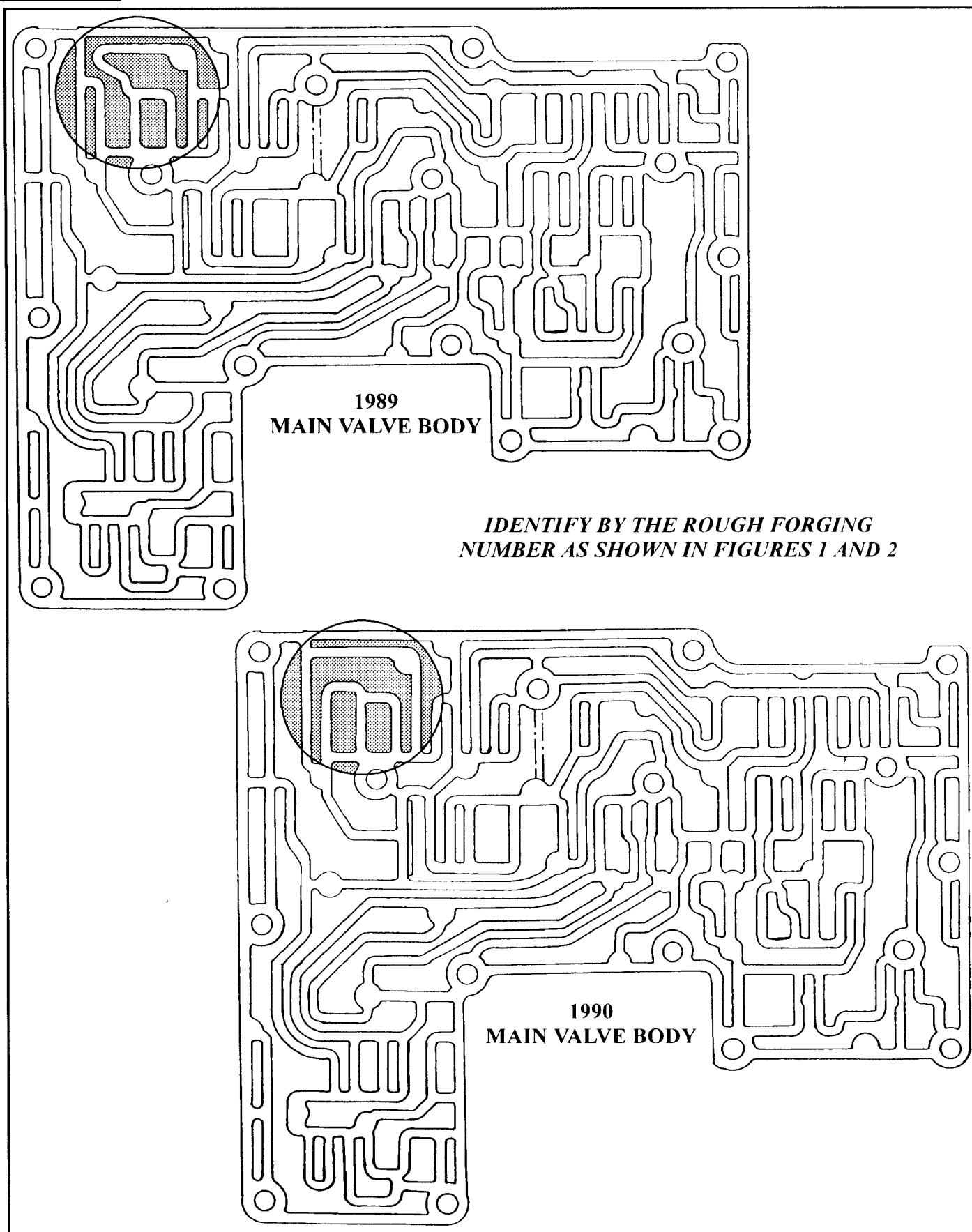


Figure 13

AUTOMATIC TRANSMISSION SERVICE GROUP



*IDENTIFY BY THE ROUGH FORGING
NUMBER AS SHOWN IN FIGURES 1 AND 2*

Figure 14

AUTOMATIC TRANSMISSION SERVICE GROUP

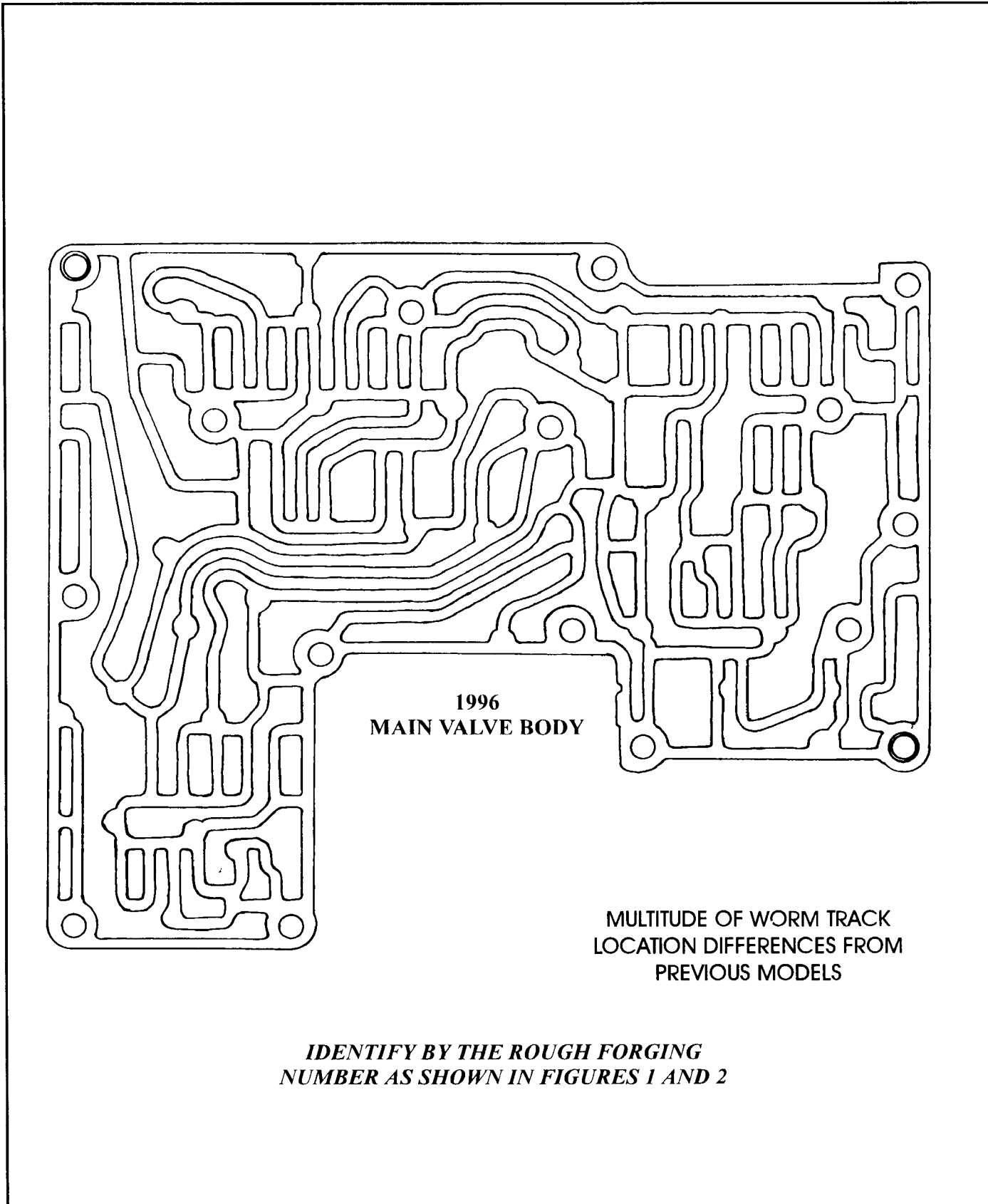


Figure 15

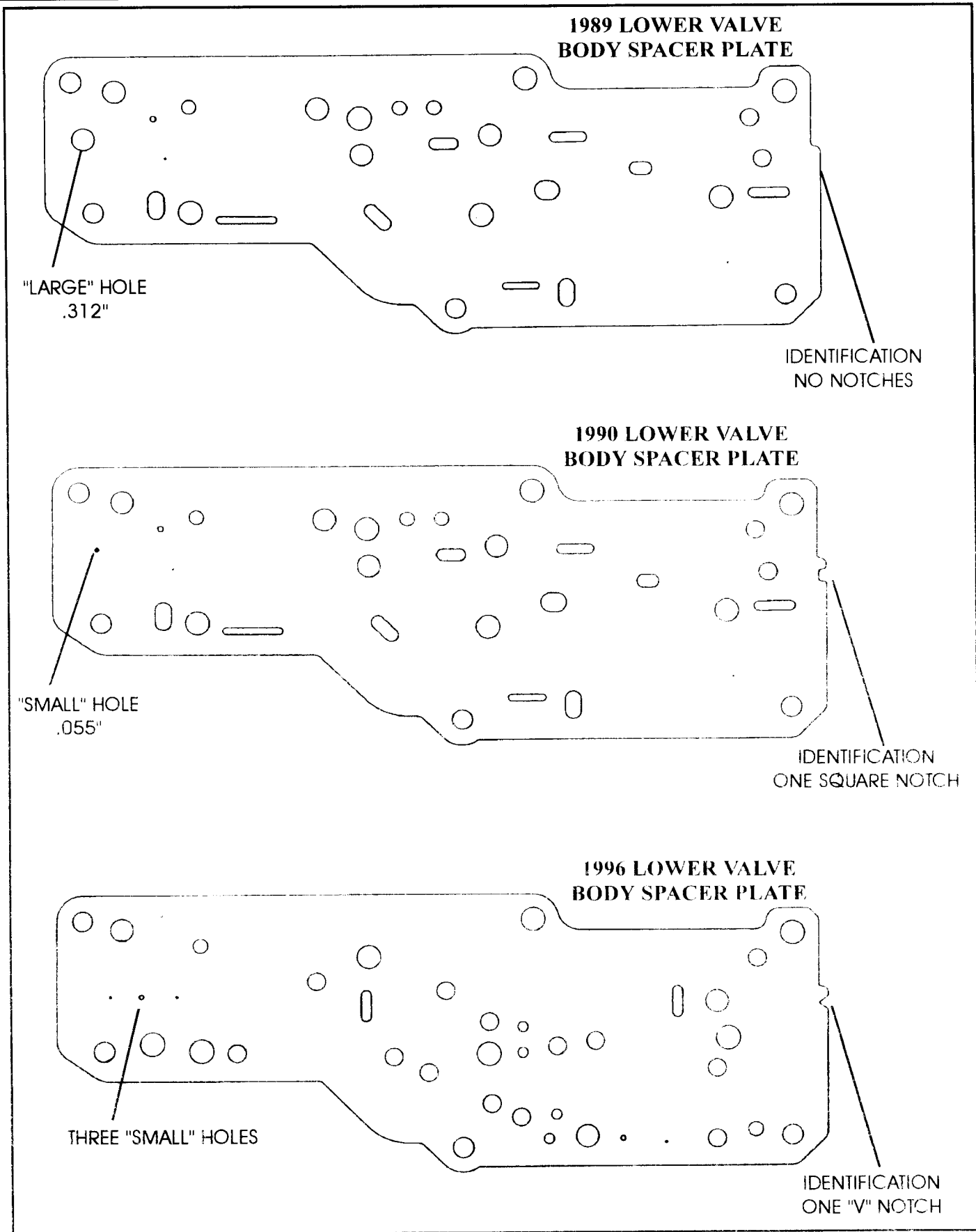


Figure 16

AUTOMATIC TRANSMISSION SERVICE GROUP

E4OD LOWER VALVE BODIES

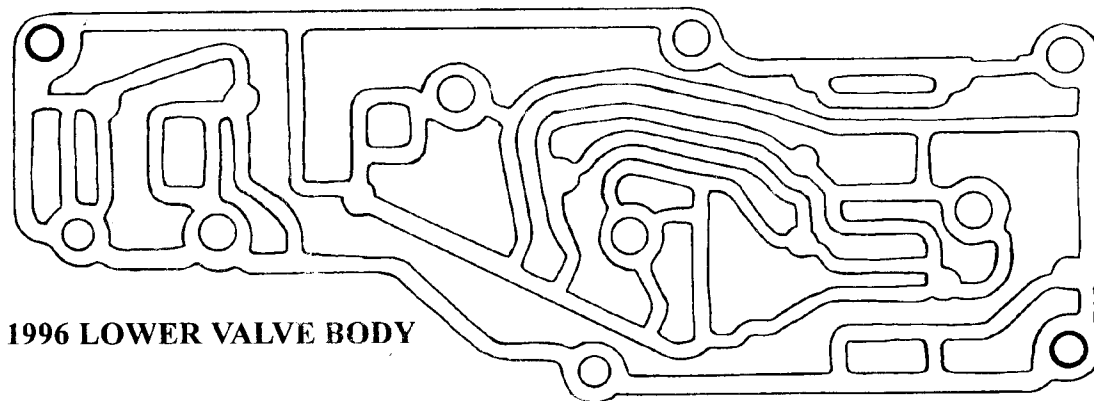
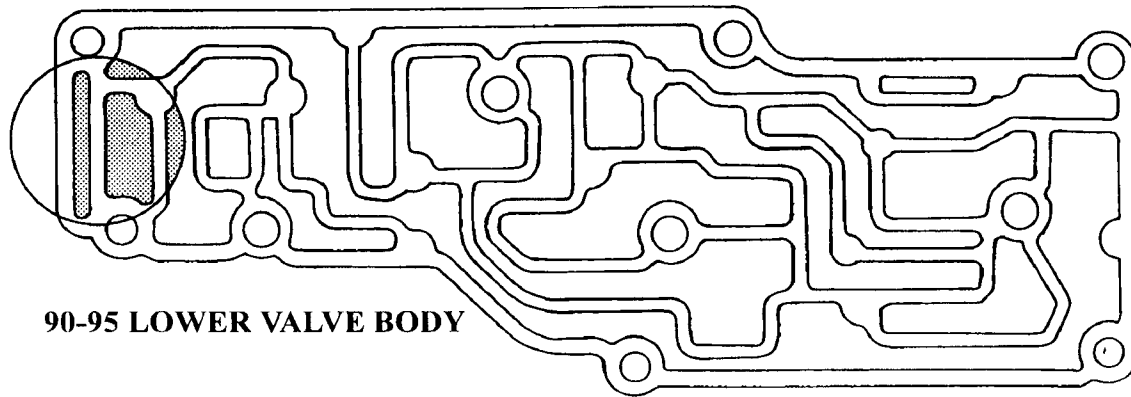
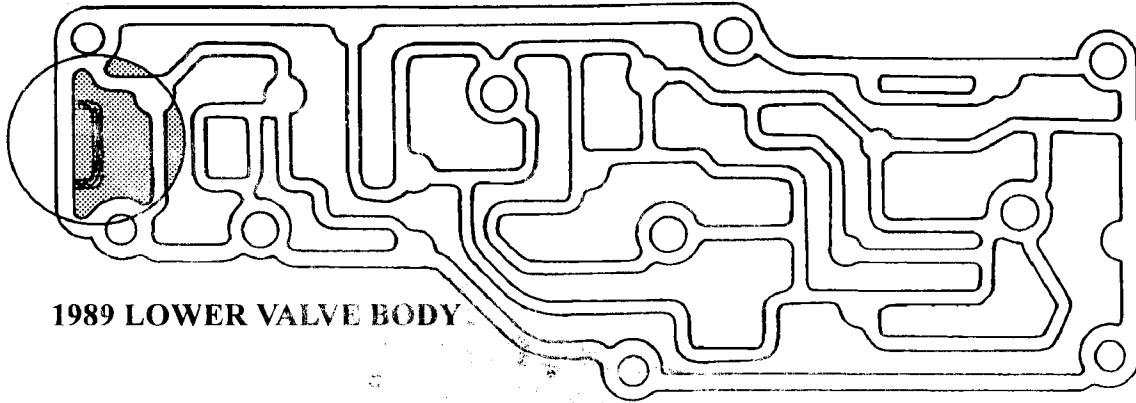


Figure 17

AUTOMATIC TRANSMISSION SERVICE GROUP

1989 E4OD CASE IDENTIFICATION
SHADED AREAS ARE DIFFERENT THAN 1990 MODEL

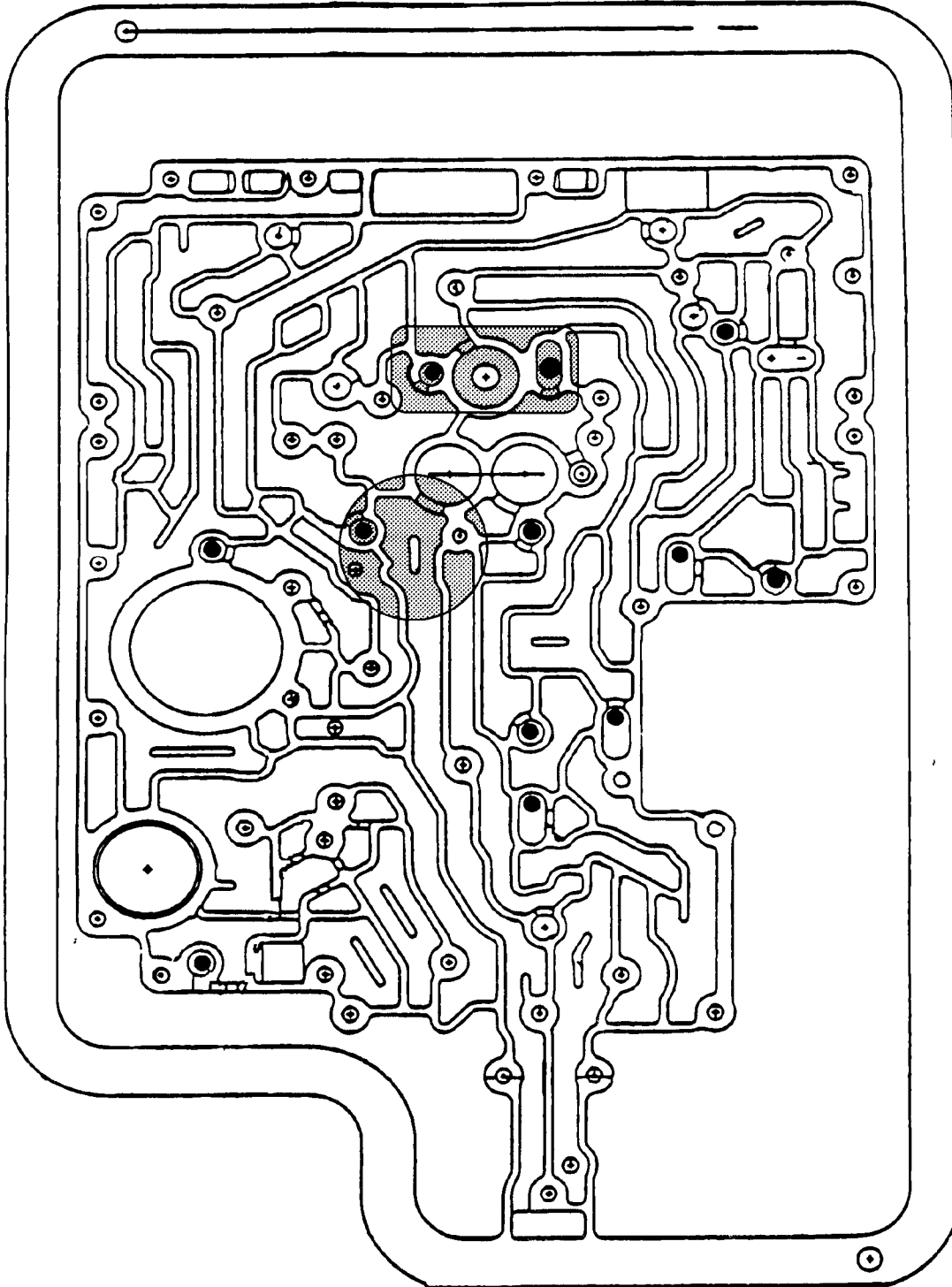


Figure 18

AUTOMATIC TRANSMISSION SERVICE GROUP

1990 E4OD CASE IDENTIFICATION
SHADED AREAS ARE DIFFERENT THAN 1989 MODEL

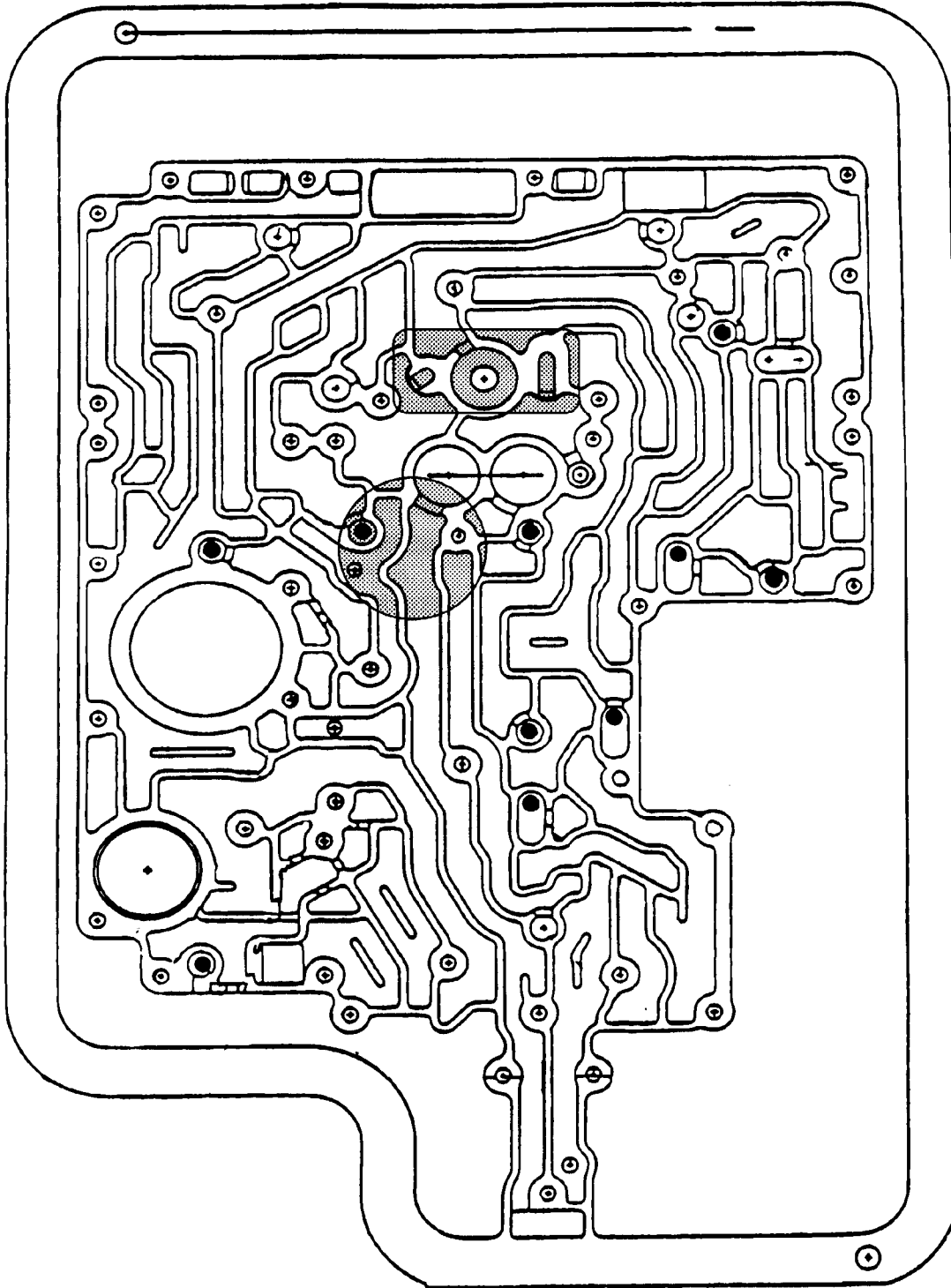


Figure 19
AUTOMATIC TRANSMISSION SERVICE GROUP

1991 E4OD CASE IDENTIFICATION

INTERMEDIATE CLUTCH ACCUMULATOR
REGULATOR FILTER ASSEMBLY ADDED HERE

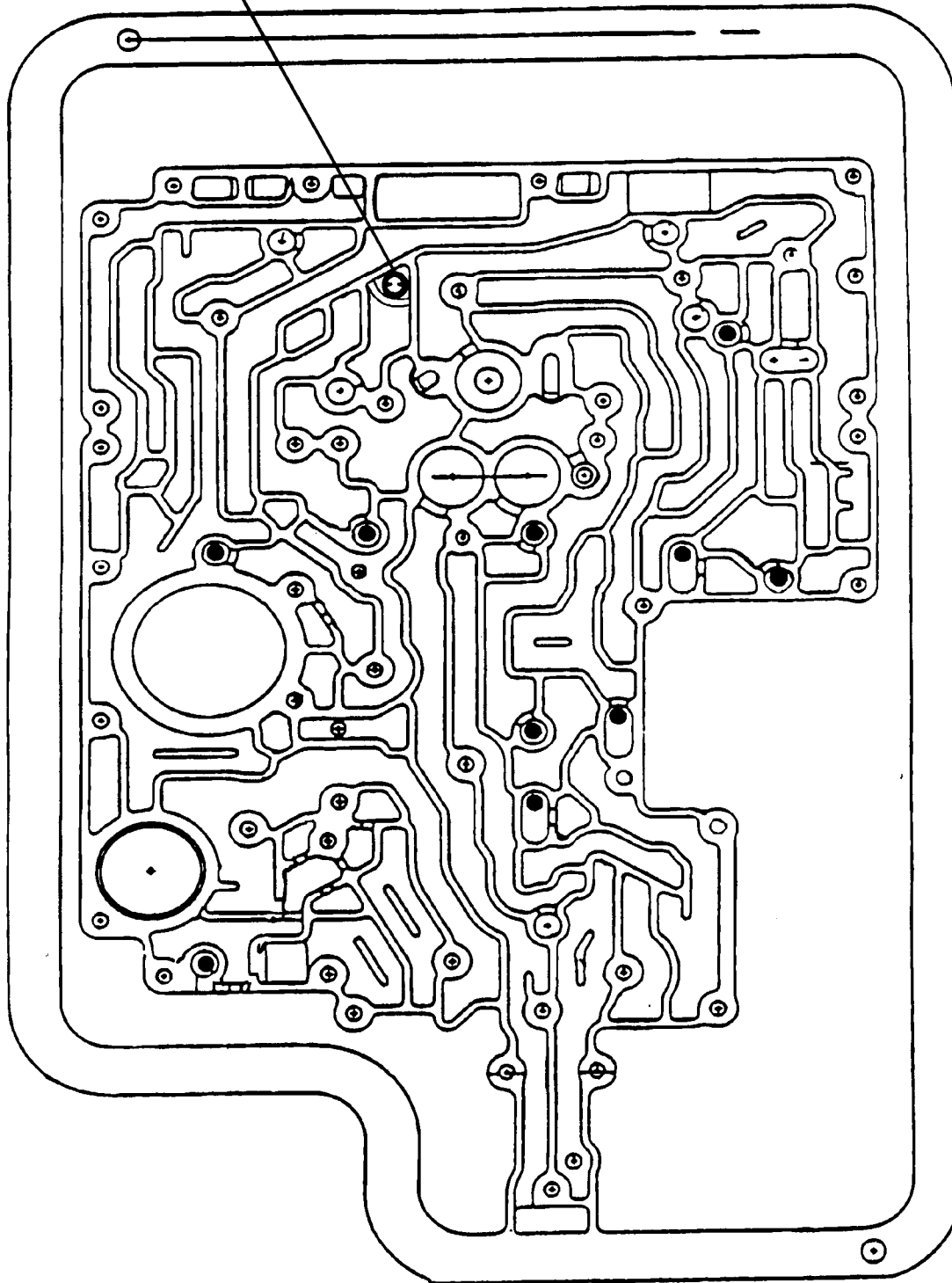


Figure 20

AUTOMATIC TRANSMISSION SERVICE GROUP

1996 E4OD CASE IDENTIFICATION

SMALL DIFFERENCES IN THIS AREA BUT
WILL INTERCHANGE WITH 1990-UP MODELS

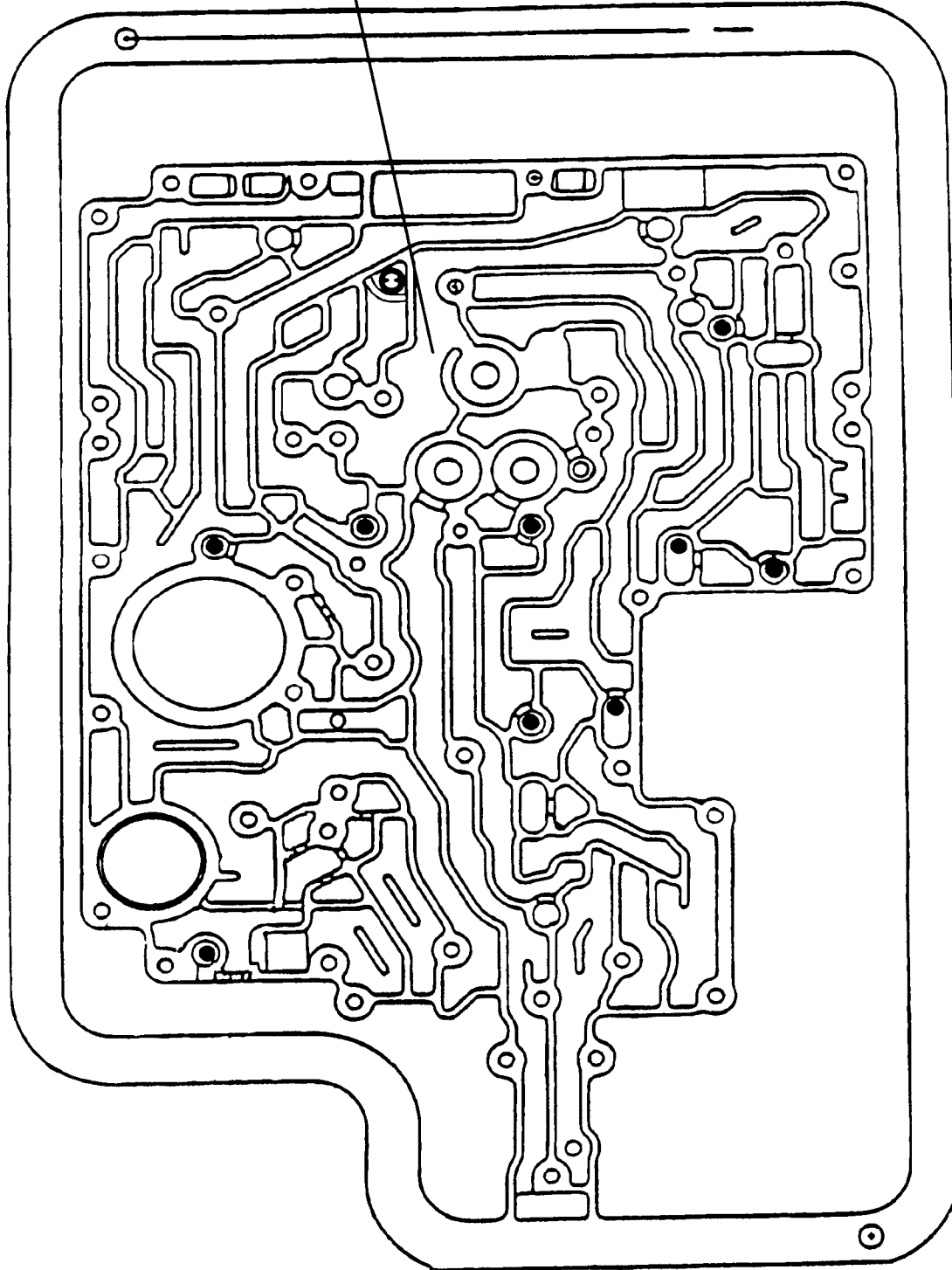


Figure 21

AUTOMATIC TRANSMISSION SERVICE GROUP



**FORD E4OD
WILL NOT HOLD IN PARK
NEW DESIGN OUTPUT SHAFT**

COMPLAINT: Vehicle will still move, or roll, *after* placing the manual shift lever in the PARK position.

CAUSE: The cause may be a broken snap ring on the output shaft, allowing the parking gear to move rearward, and then the parking pawl cannot engage into the parking gear. Refer to Figure 22.

Action must be taken based on the build date as identified on the transmission I.D. tag. Refer to Figure 23 for build date identification.

CORRECTION: There is now available a new service package, under OEM part number F0TZ-7A040-A, that includes a new design extension housing with a new "Boss" cast into it to prevent the parking gear from moving rearward in case the snap ring breaks (See Figure 24). The service package also includes a new "*high strength*" snap ring, and a snap ring installation aid, as shown in Figure 25.

The Output Shaft has also been redesigned for 1990 and later models, with the splines removed from behind the parking gear snap ring groove, which creates an increased shoulder for the snap ring, and helps prevent the snap ring from breaking. Refer to Figure 26.

SERVICE INFORMATION:

E4OD Extension Housing Service Package F0TZ-7A040-A

Includes the following:

- 1. 2nd Design Extension Housing With Added Boss.
- 2. New Design "High Strength" Snap Ring.
- 3. Snap Ring Installation Aid.

1989 Output Shaft, 2WD, 7T Speedo (1st Design) E9TZ-7060-A

1989 Output Shaft, 2WD, 8T Speedo (1st Design) E9TZ-7060-C

1989 Output Shaft, 4WD, (1st Design) E9TZ-7060-D

1990 Output Shaft, 2WD, 7T Speedo (2nd Design) F0TZ-7060-E

1990 Output Shaft, 2WD, 8T Speedo (2nd Design) F0TZ-7060-F

1990 Output Shaft, 4WD, (2nd Design) F0TZ-7060-G

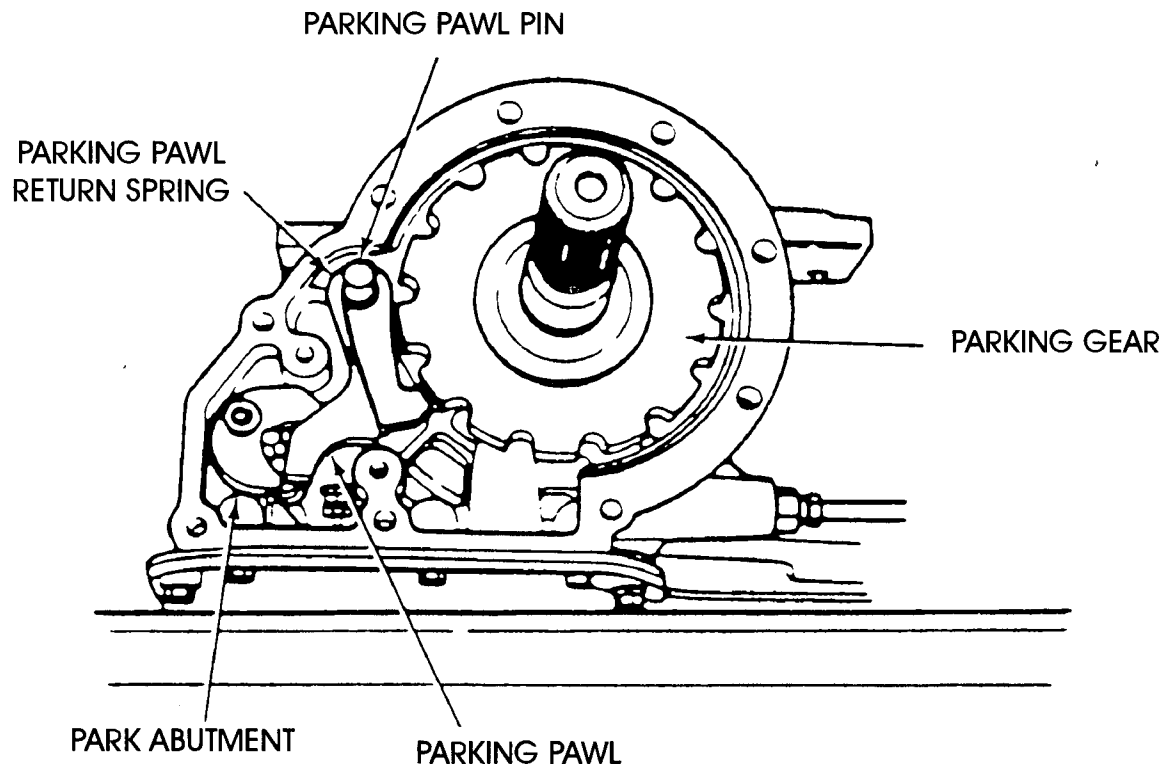
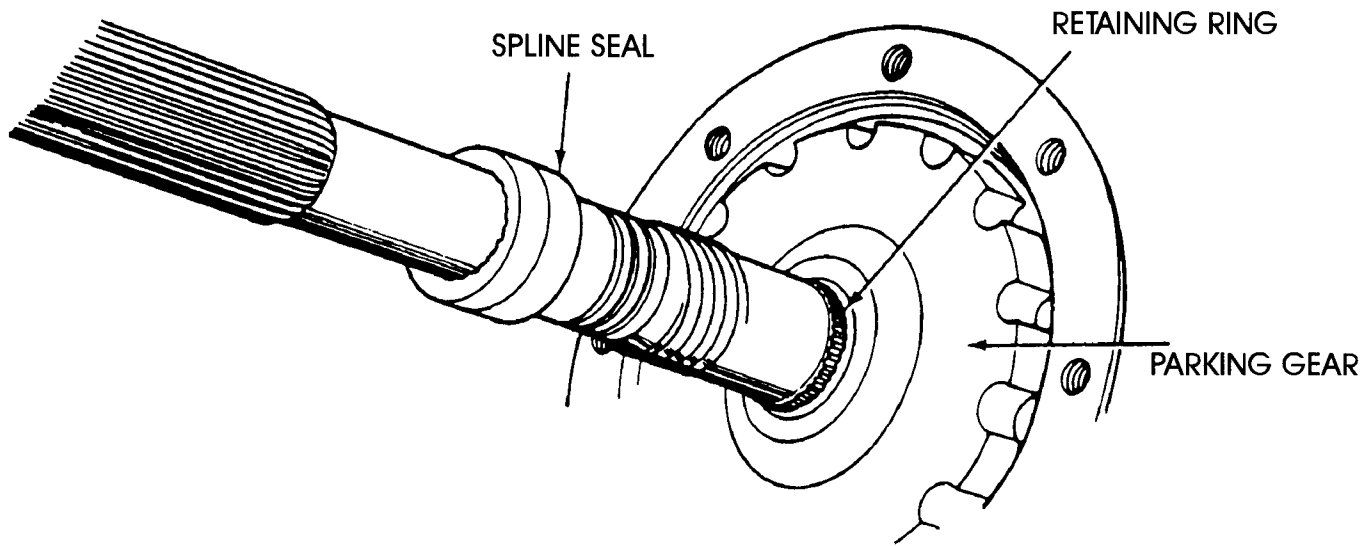


Figure 22

AUTOMATIC TRANSMISSION SERVICE GROUP

E40D SNAP RING CONCERN SOME 4 x 2's WITH 1 PIECE DRIVESHAFTS

- The following actions must be taken based on the build date as identified on the transmission I.D. Tag:
- **E250-E350 7.3L Diesel**
 - Any transmission built in 1988 must be repaired
 - Any transmission built in 1989 prior to Oct. 27, 1989 (9K27) must be repaired
- **All Other Applications (except 5.0L)**
 - Any transmission built in 1988 must be repaired
 - Any transmission built in 1989 prior to Dec. 1, 1989 (9M01) must be repaired
- Any transmission built in 1990 does not need repair
- BUILD DATE IDENTIFICATION IS AS FOLLOWS:

- 1988 — 8 before the letter
REPAIR ALL

E9TP-CB 00002019
PRA-C4 BD-8J29

 2411 00014953

- 1989 — 9 before the letter

- E250-E350 7.3L Diesel —
A01 thru K26 • REPAIR
- All Other — (except 5.0L)
A01 thru L30 • REPAIR

F0UP-CA 00004420
PRA-EA BD-9K25

 5420 00004420

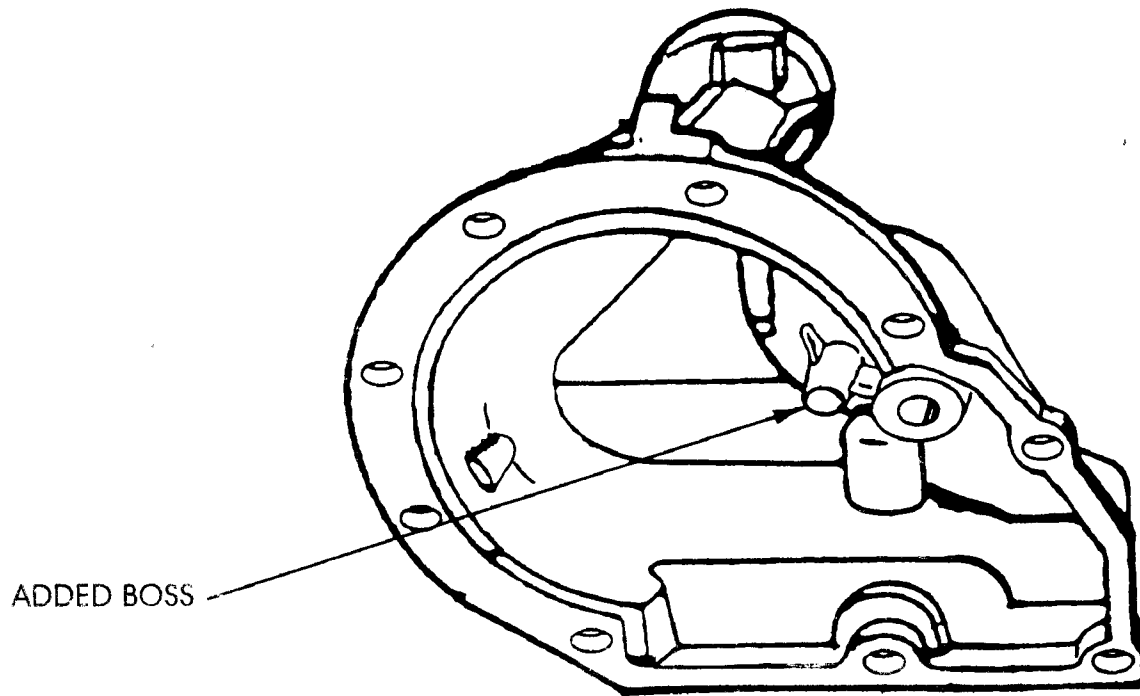
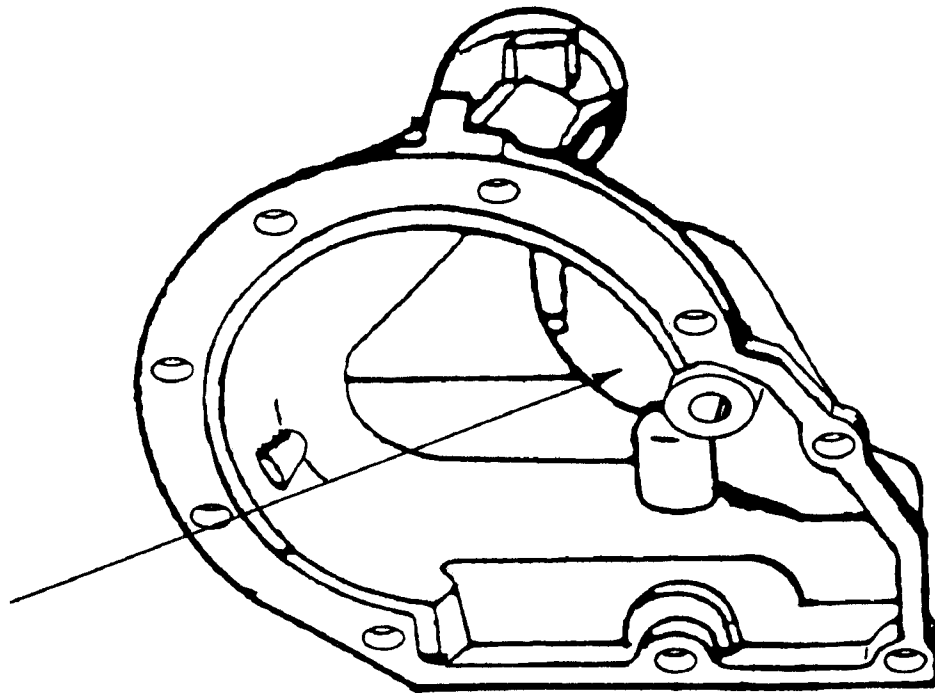
- 1990 — 0 before the letter
Does Not Need Repair

F0TP-EA 00014953
PRA-V3 BD-0B28

 3001 00002019

If the identification tag is missing or does not conform to the above guidelines, then unit must be repaired.

Figure 23

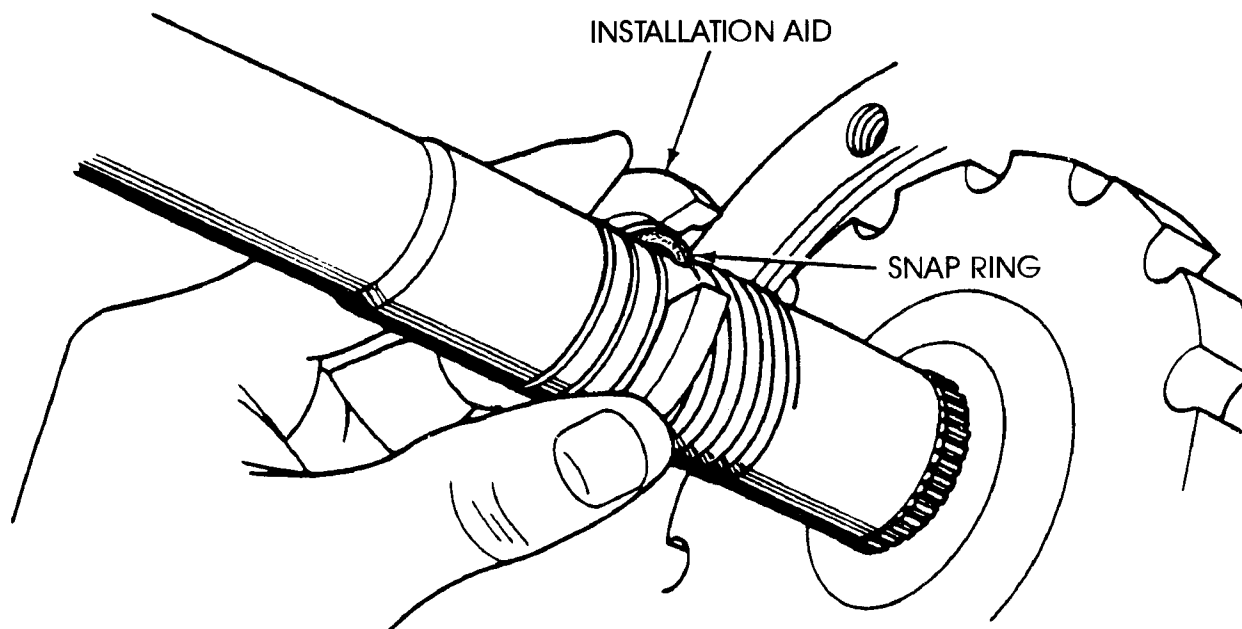


NEW DESIGN

Figure 24

AUTOMATIC TRANSMISSION SERVICE GROUP

- (1) Remove installation aid with retaining ring from package. Hold ring in the installation aid opposite opening and place installation aid on the output shaft, just before speedo teeth, with ring facing transmission. Retaining ring ends must be in installation aid opening. Installation aid is to prevent the ring from being spread too far apart.



- (2) Hold snap ring pliers parallel to output shaft and expand snap ring within the installation aid.
- (3) Slide snap ring over the speedo teeth and release the snap ring when the installation aid is against the parking gear

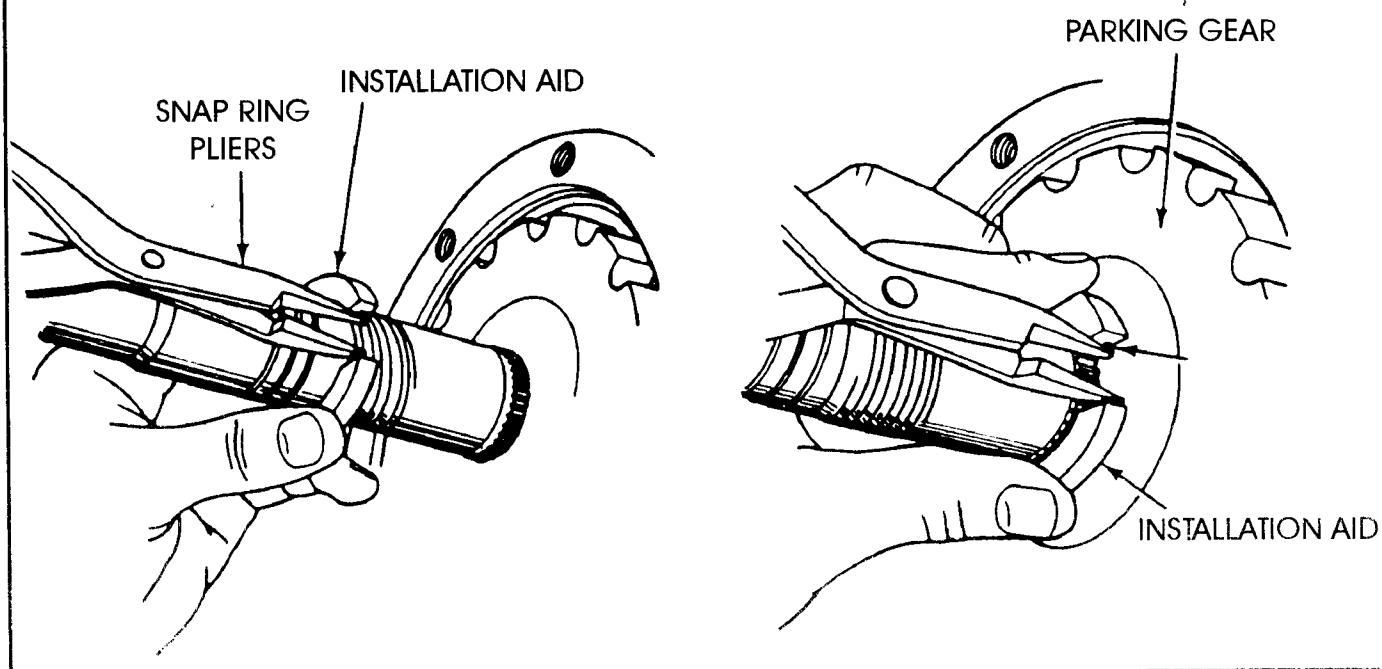


Figure 25

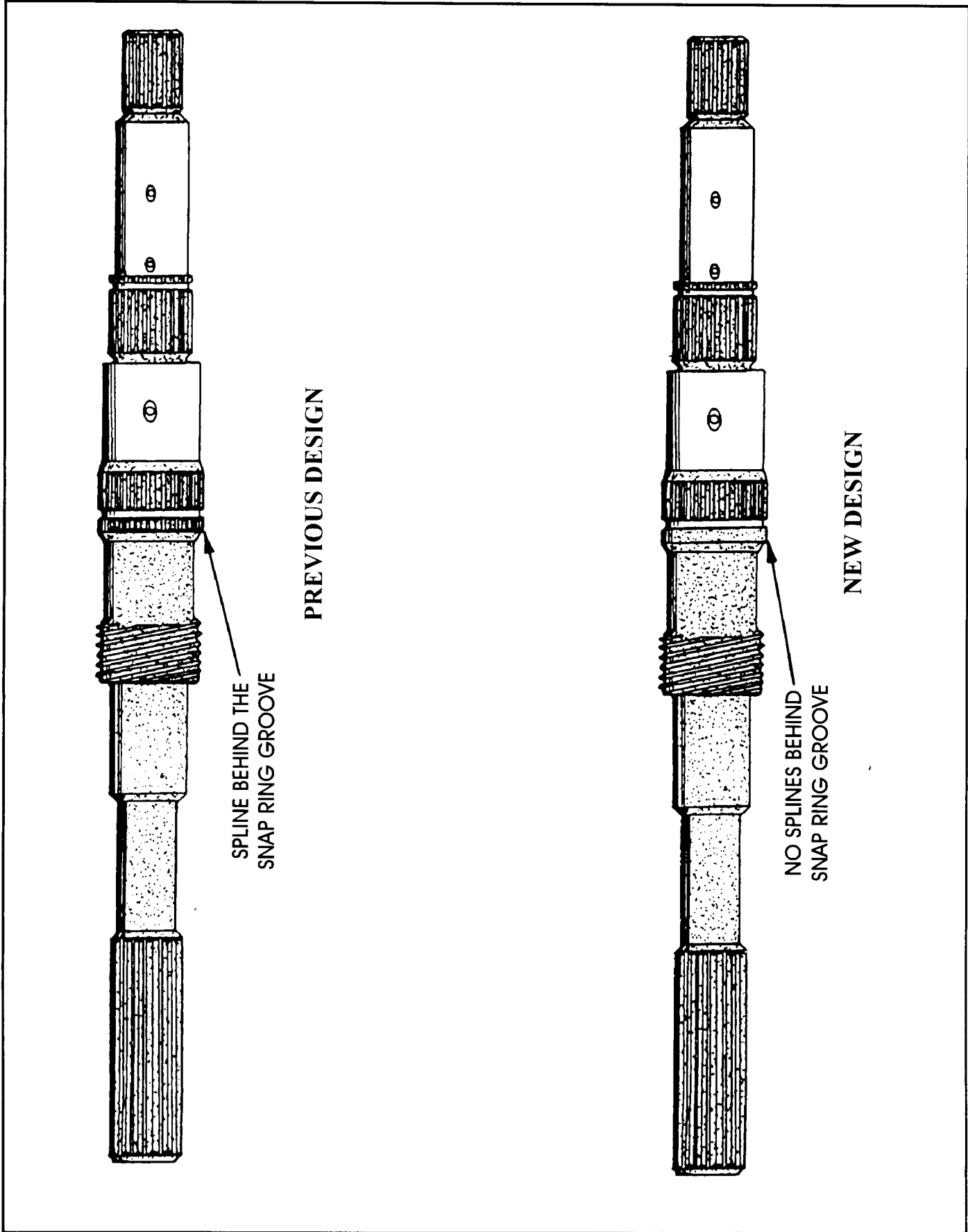


Figure 26

AUTOMATIC TRANSMISSION SERVICE GROUP

FORD E4OD OVERDRIVE SECTION FAILURE

COMPLAINT: Overdrive planetary and overdrive sprag failure due to lack of lubrication.

CAUSE: The cause may be, a plugged or restricted lube passage in the oil pump cover. There is a valve and spring under the orificed cup plug in the pump cover. The valve is made of plastic and is prone to melting, and will restrict or block the passage.

CORRECTION: To check for restriction, blow air into the hole in pump cover as shown in Figure 27, and air should exit from the holes in rear of stator shaft, as shown in Figure 28. If the passage is restricted or blocked the orificed cup plug must be removed, the plastic valve assembly replaced, and the passage thoroughly cleaned (See Figure 28)

SERVICE INFORMATION:

Check Valve, Spring, and Cup Plug Assembly E9TZ-7H132-B

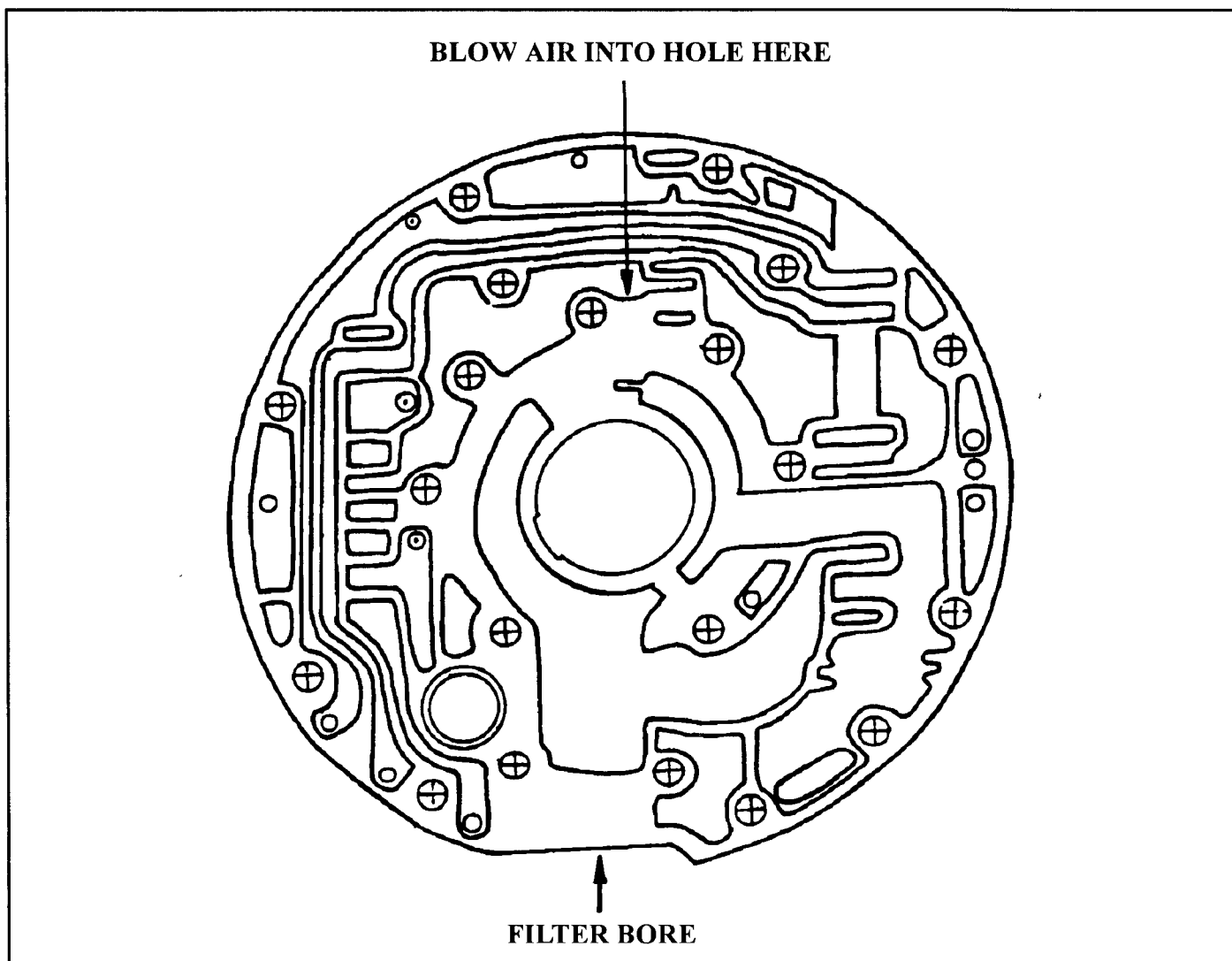
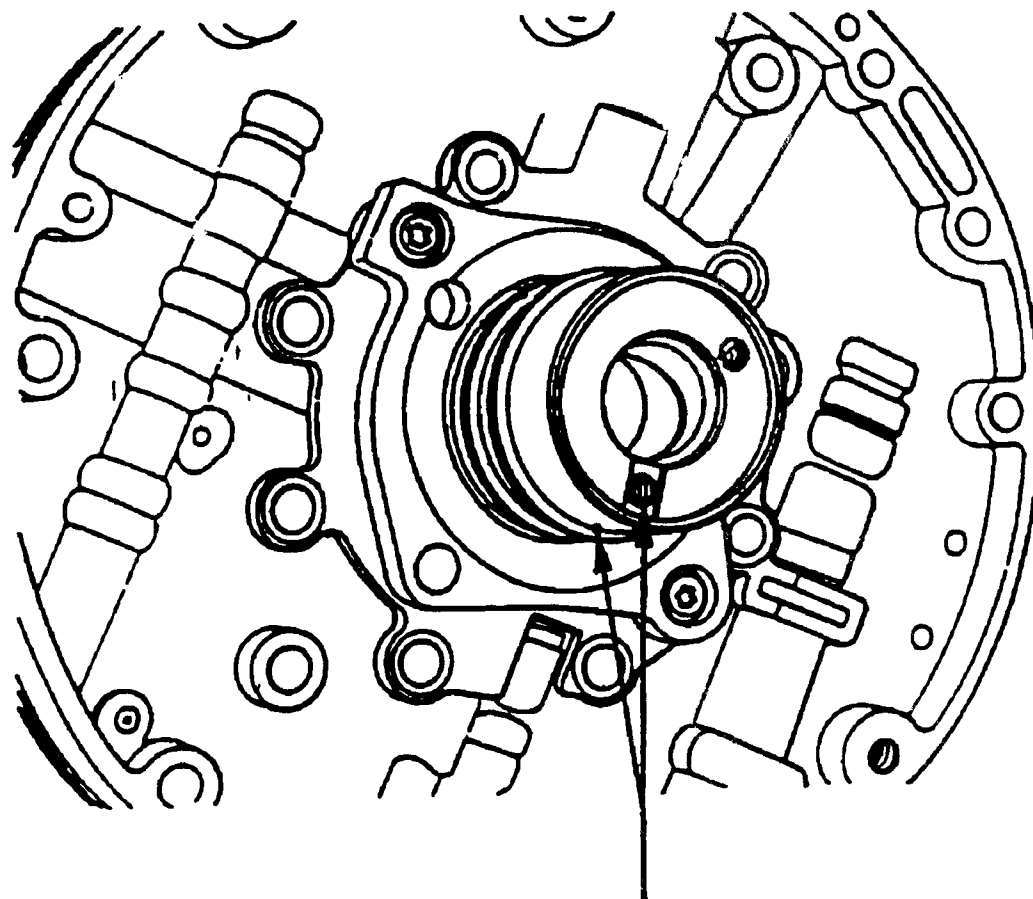
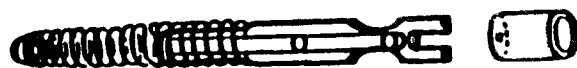


Figure 27



**AIR SHOULD EXIT FROM ORIFICED
CUP PLUG AND SMALL LUBE HOLE IN
FRONT OF BUSHING JOURNAL**



**OEM PART NUMBER
E9TZ-7H132-B**

Figure 28

AUTOMATIC TRANSMISSION SERVICE GROUP



Technical Service Information

FORD E4OD HARSH 3-4 SHIFT

COMPLAINT: Harsh 3-4 shift, and/or, upon transmission disassembly the Overdrive Clutch retaining snap ring is dislodged from the groove (See Figure 29).

CAUSE: Insufficient tension on the Overdrive Clutch Snap Ring.

CORRECTION: Install a new design (Thicker) snap ring that has more tension than the previous design. The new design snap ring is .199" thick and the previous design is .159" thick, as shown in Figure 29.

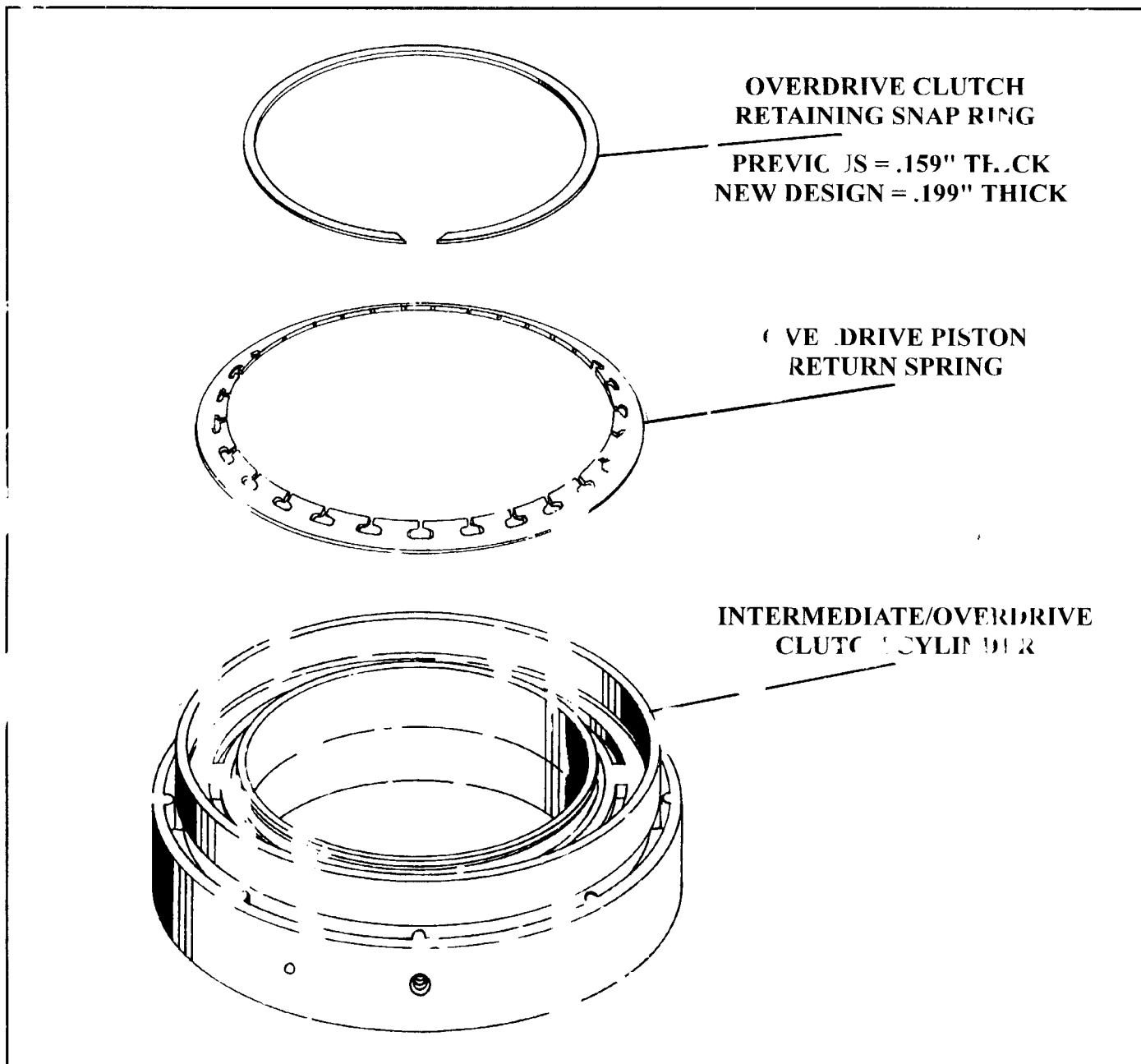


Figure 29



Technical Service Information

FORD E40D

LOW SPRAG RACE AND BEARING CHANGE

CHANGE: The Low Roller Clutch Inner Race received a dimensional change to accommodate a revised thrust bearing., on February 24, 1989, as a running change for 1989 models.

REASON: Greatly improved durability of the thrust bearing.

PARTS AFFECTED:

- (1) **LOW ROLLER CLUTCH INNER RACE** - As of 2/24/89, the Low Roller Clutch Inner Race height has been reduced by .030" to accommodate a revised hub to race thrust bearing. The previous inner race height was 1.043" and the new design is 1.013", as shown in Figure 30.
- (2) **HUB TO RACE THRUST BEARING** - The previous thrust bearing was a **2 Piece** (open face) design, and the new design is a **3 Piece** (closed) design bearing. The thickness of the previous 2 piece thrust bearing is .110" thick, and the new design 3 piece bearing is .140" thick, so that it is compatible with the new thinner inner race (See Figure 30).

INTERCHANGEABILITY:

The previous and new design bearings and races are interchangeable as a set only. The previous design race **must** be used with the previous design bearing, and the new design race **must** be used with the new design bearing. However, the new design bearing and inner race is the preferred design level to be used in all models.

SERVICE INFORMATION:

2 Piece Thrust Bearing (Before 2/24/89)	E7DZ-7D422-A
3 Piece Thrust Bearing (After 2/24/89)	E6DZ-7G178-A
3 Piece Thrust Bearing, Inner Race, and Hub (After 2/24/89)	E9TZ-7D164-B

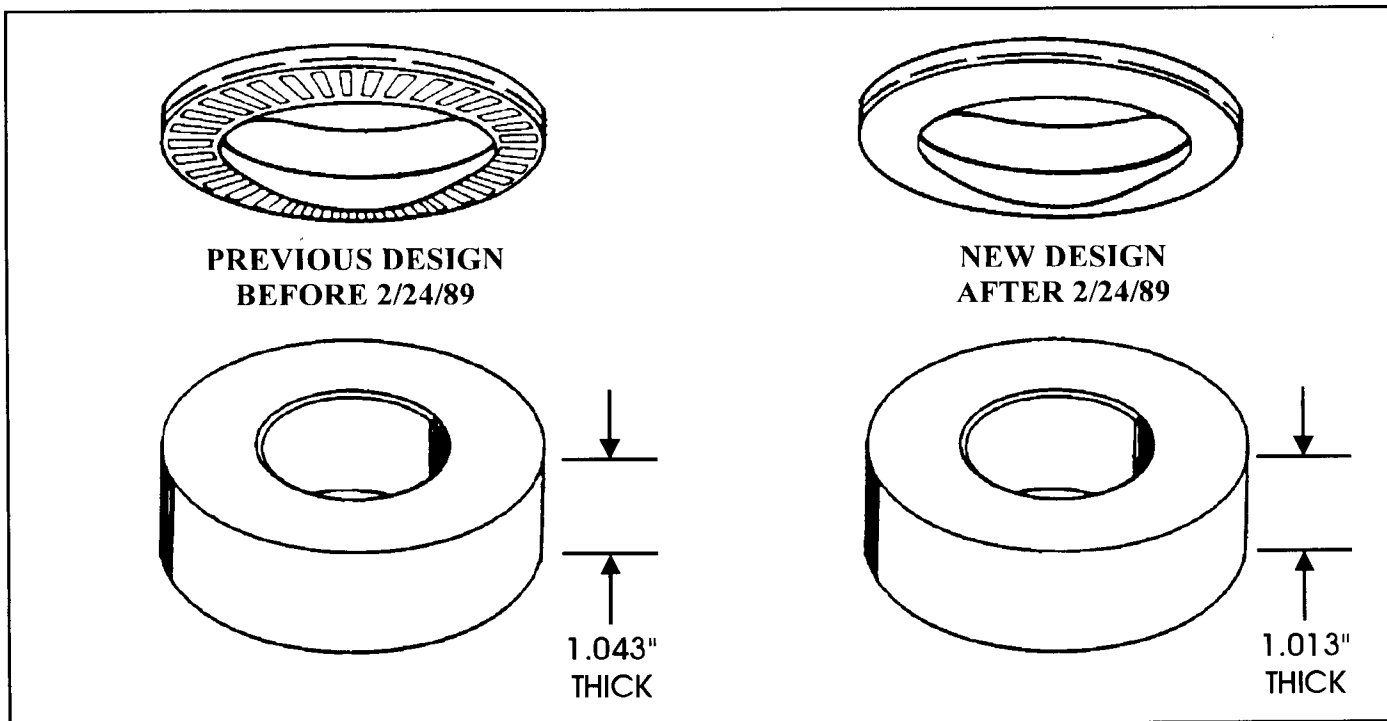


Figure 30

FORD E40D CHECK VALVE ADDED TO COOLER FITTING

CHANGE: Beginning in mid-year of the 1990 model year, Ford Motor Company incorporated a check valve into the rear cooler line fitting as shown in Figure 31.

REASON: To eliminate drainback through the cooler and a delayed engagement after overnight set.

PARTS AFFECTED:

- (1) **REAR COOLER FITTING** - Now incorporates a check valve inside the cooler line fitting, as shown in Figure 31. There are two different size fittings, one for 3/8" cooler lines and one for 5/16" cooler lines.

NOTE: There was also an "in-line" fitting released for service, for installation between the transmission cooler and the transmission, in the cooler return line (See Figure 32). This service fitting was intended for 1989 and early 1990 models only that did not have the case modifications necessary to install the cooler line fitting that incorporates the check valve.

CAUTION: *If a 1989 or early 1990 model transmission case is being replaced with a case incorporating the check valve, inspect the cooler line between the transmission cooler and transmission. If an "in-line" converter anti-drainback check valve exists, remove and replace it with a coupling.*

Under NO circumstances should both check valves be used, or a restriction will result.

SERVICE INFORMATION:

In-Line Check Valve Service Package	FOTZ-7D174-A
Cooler Fitting For 5/16" Cooler Lines (Late 90-Up)	FOTZ-7D174-B
Cooler Fitting For 3/8" Cooler Lines (Late 90-Up)	FOTZ-7D174-C

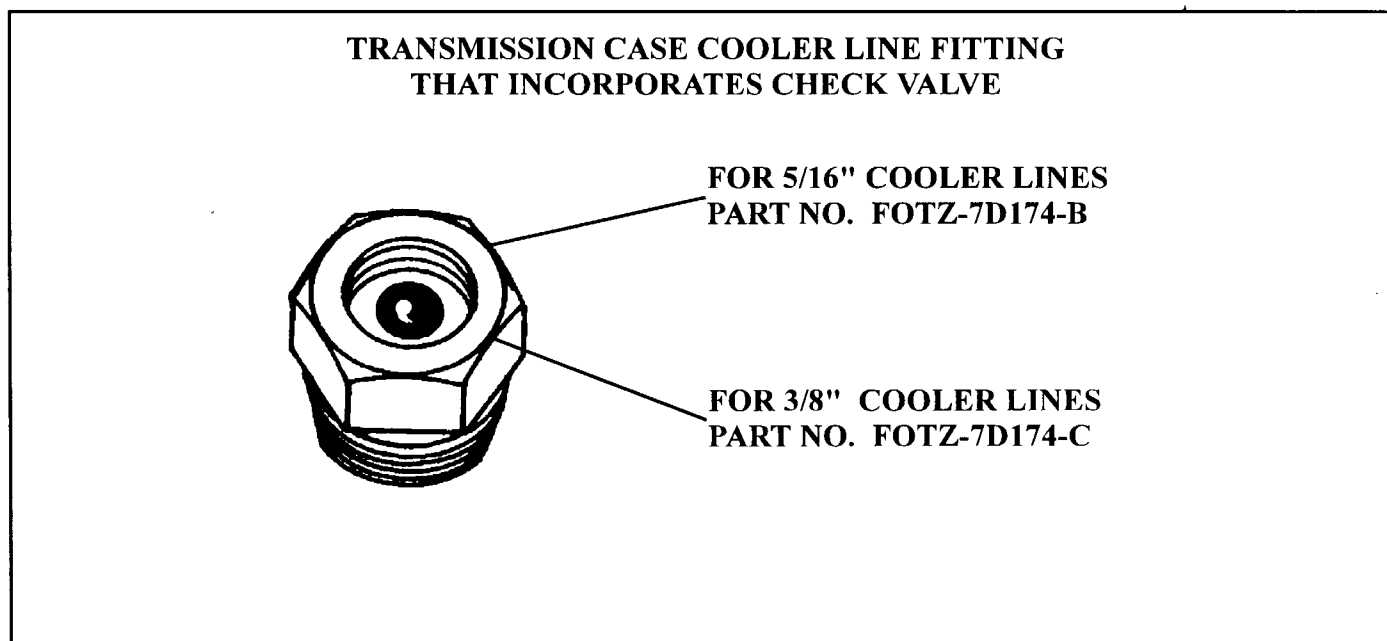
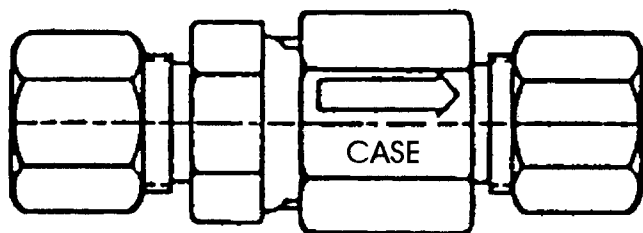


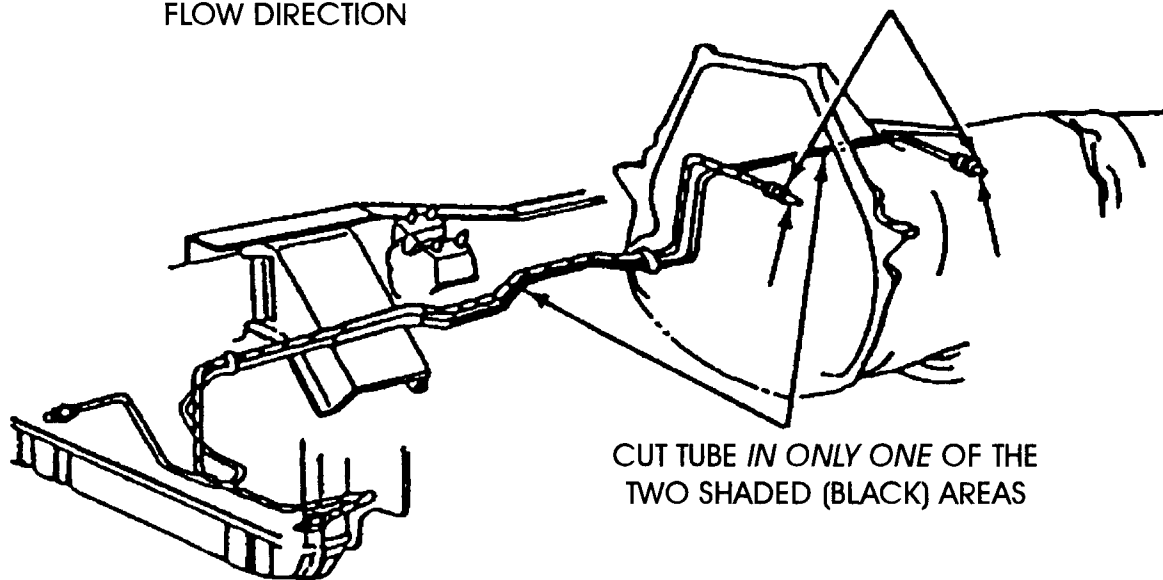
Figure 31

**"IN-LINE" COOLER CHECK VALVE FOR SERVICE
PART NUMBER FOTZ-7D174-A**



CHECK VALVE
FLOW DIRECTION

FITTINGS



CUT TUBE *IN ONLY ONE* OF THE
TWO SHADED (BLACK) AREAS

INSTALL IN-LINE CHECK VALVE
IN COOLER LINE GOING TO REAR
TRANSMISSION CASE FITTING IN THE
DIRECTION OF ARROW SHOWN ABOVE

Figure 32



Technical Service Information

FORD E4OD CONVERTER CLUTCH SHUDDER 1989 - 1991 MODELS ONLY

COMPLAINT: Soft converter clutch apply and/or "Shudder" under hard acceleration.

CAUSE: Low converter clutch apply pressure and/or converter clutch exhaust orifice too small.

CORRECTION: Replace the converter clutch regulator valve spring, located in the pump cover with a "SGSF E4OD" shudder fix spring as shown in Figure 33. Also drill the converter clutch exhaust orifice out to .076", as shown in Figure 33.

It is also recommended to drill out the cooler orifice to .090" for increased lube flow, as shown in Figure 33.

NOTE: Ford Motor Company replaced this spring with a heavier spring in 1992 and later models, so ensure the spring you are installing is *heavier* than the one you are removing.

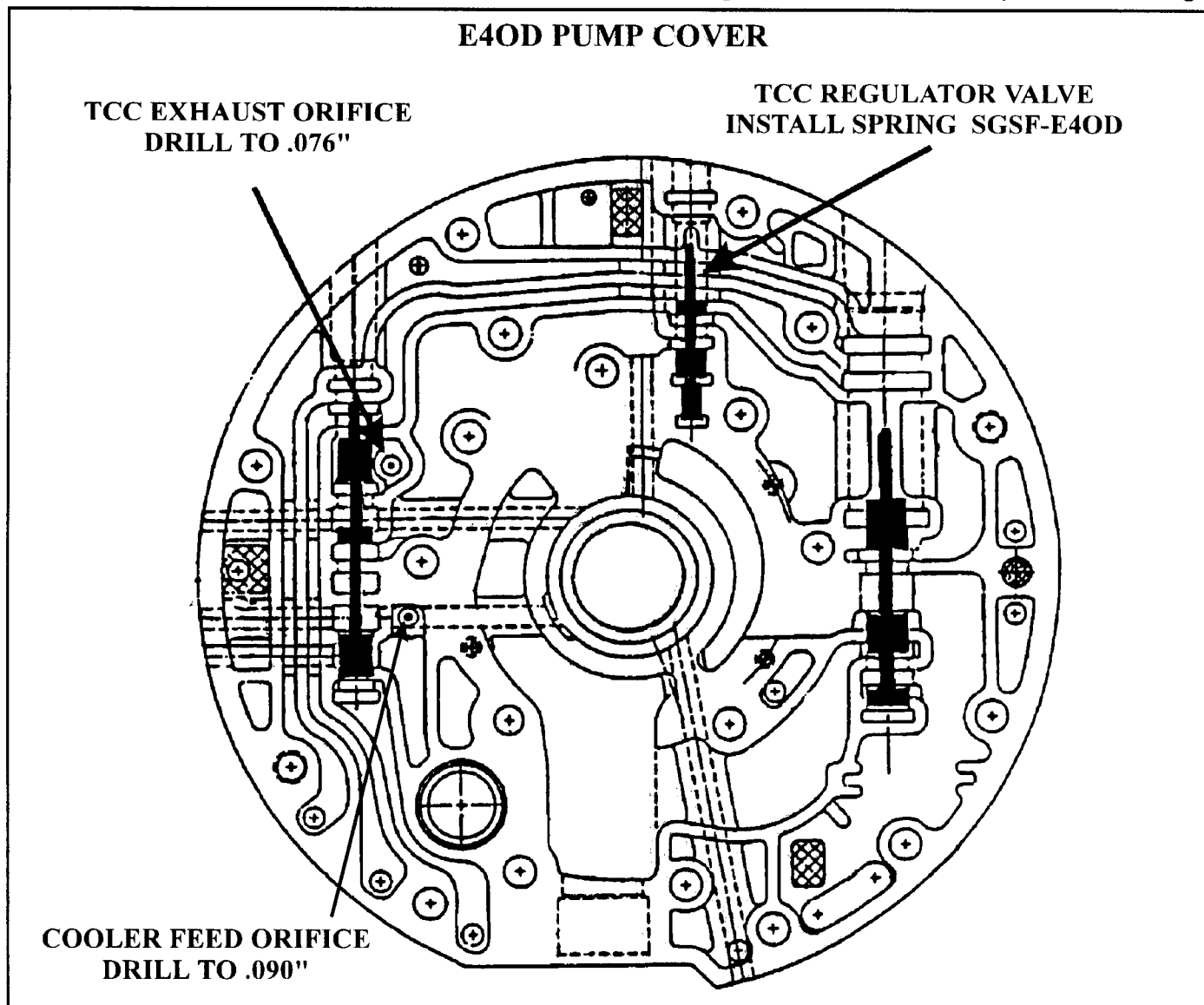


Figure 33

AUTOMATIC TRANSMISSION SERVICE GROUP



Technical Service Information

FORD E4OD FORWARD CLUTCH PISTON RETURN SPRING

COMPLAINT: Forward clutch piston return spring fatigued, worn, and/or broken.

CAUSE: The cause may be, improper orientation of steel ring on top of the forward clutch piston, and the forward clutch piston return spring.

CORRECTION: Position the forward clutch piston return spring so that both ends of the steel ring are visible within the space between the two adjacent fingers of the return spring as shown in Figure 34.

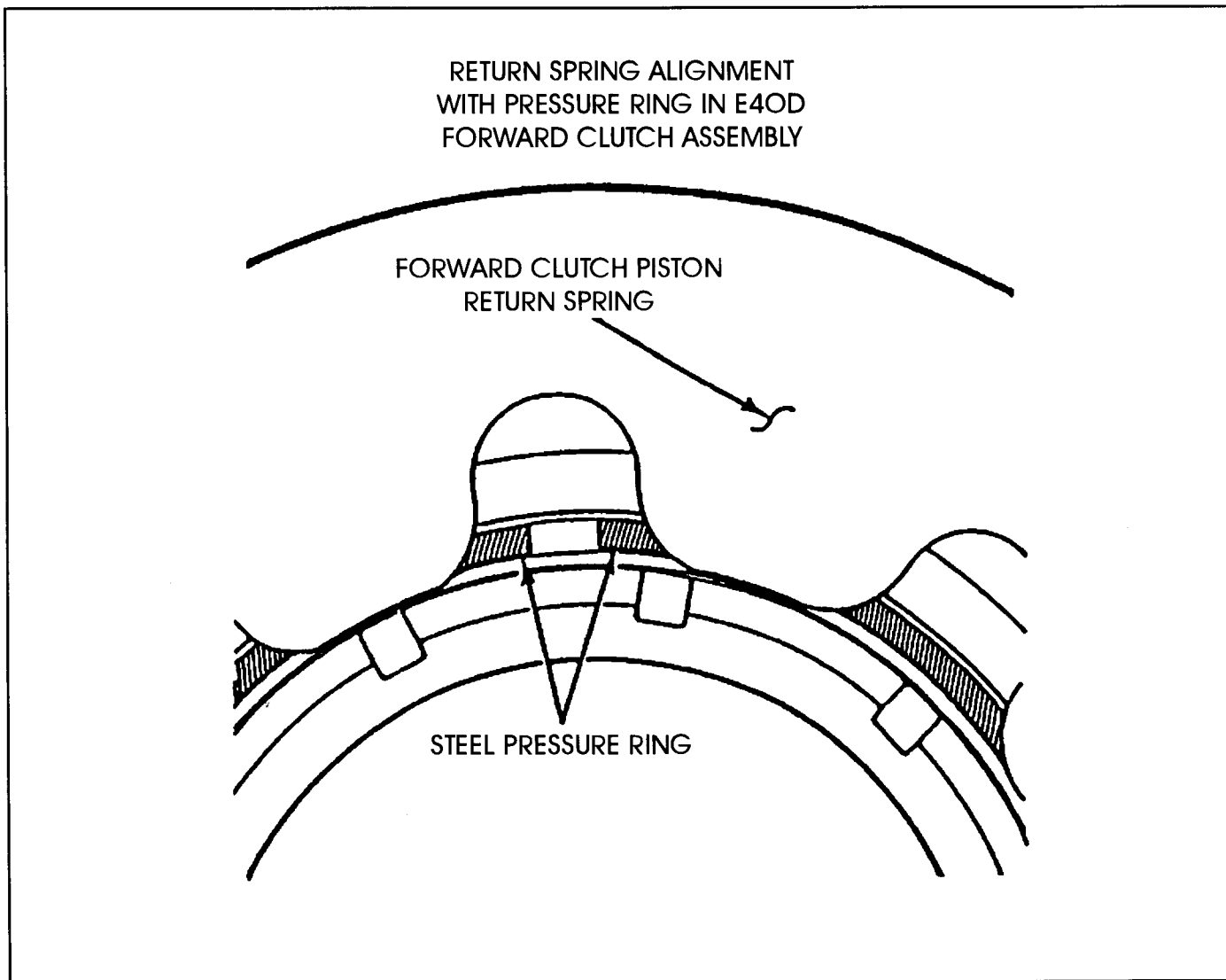


Figure 34

FORD E4OD NO FORWARD ENGAGEMENT

COMPLAINT: A no forward movement condition, until the manual shift lever is placed in the Manual Low position.

CAUSE: The cause may be, an incorrectly installed new plastic caged Low Roller Clutch Assembly, that was introduced in 1994.

CORRECTION: Use the following procedure any time the Low Roller Clutch is being replaced, using the New Plastic Caged Low Roller Clutch Assembly.

- (1) Remove the upper snap ring, brass bushing, roller clutch assembly, and the lower snap ring, as shown in Figure 35. *Discard all parts removed!*
- (2) Install the New Plastic Cage Low Roller Clutch Assembly through the *rear* side of the Reverse Clutch Hub, with the tabs on the rear edge. Seat the Low Roller Clutch into the Reverse Clutch Hub, and rotate clockwise to seat rollers and lock tabs in place. Refer to Figure 36 for proper installation.

SERVICE INFORMATION: 94-8-20

Plastic Caged Low Roller Clutch Assembly F3TZ-7A089-A

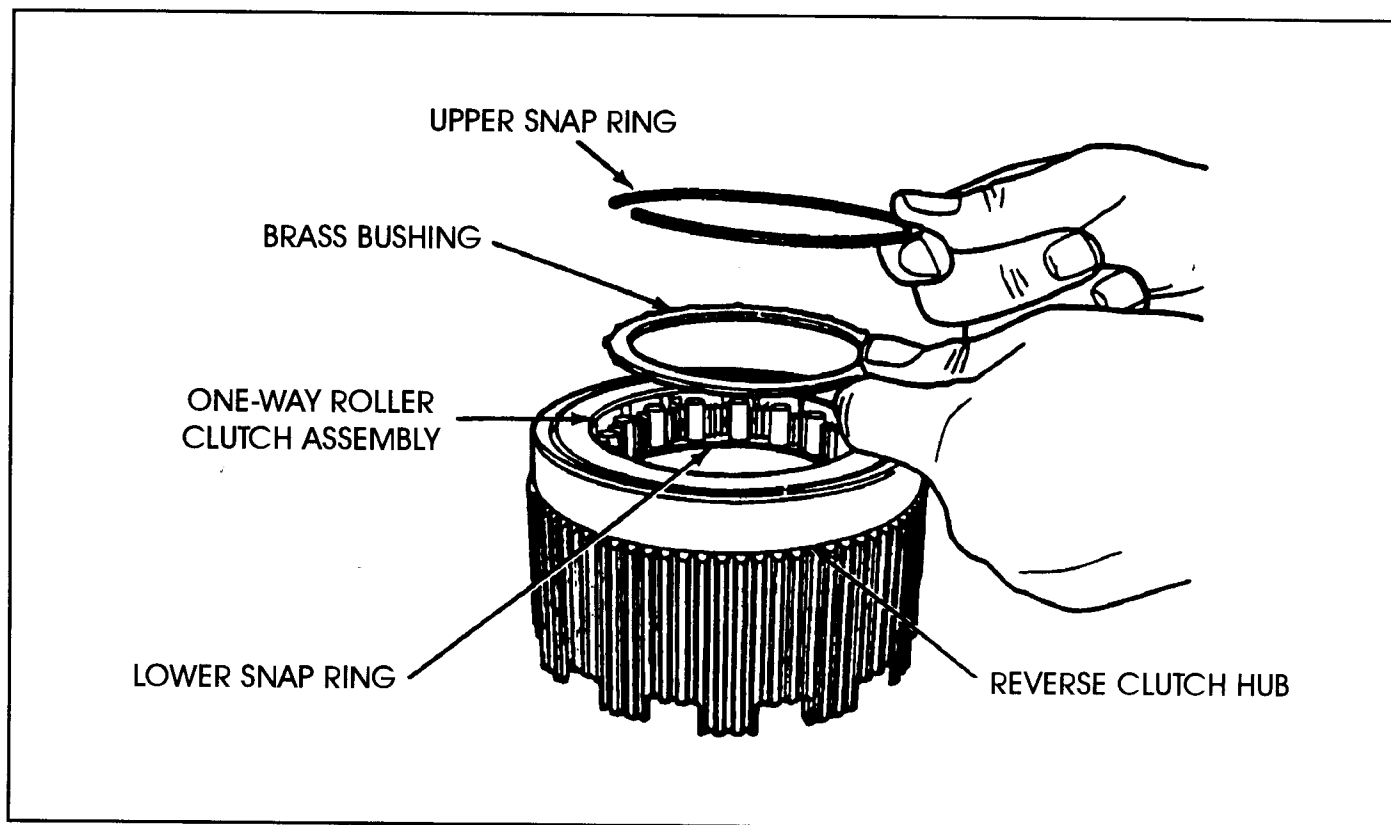
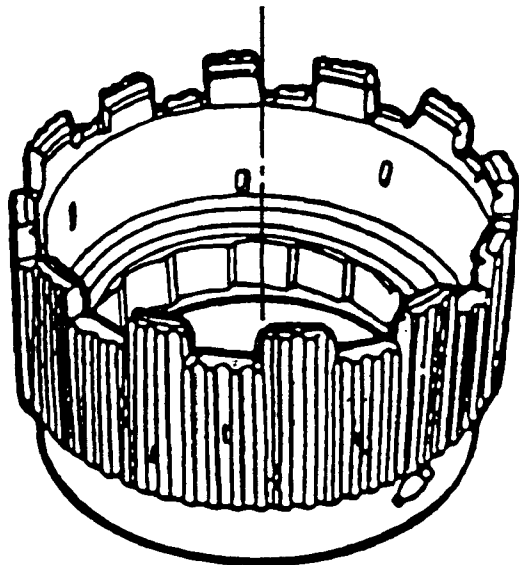
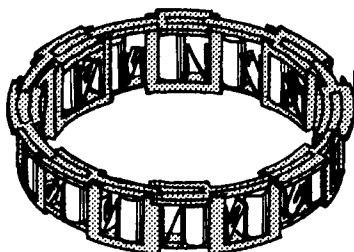


Figure 35

E4OD PLASTIC LOW ROLLER CLUTCH ASSEMBLY

***"INCORRECTLY"
INSTALLED***

NOTE TABS ON
TOP OUTER EDGE

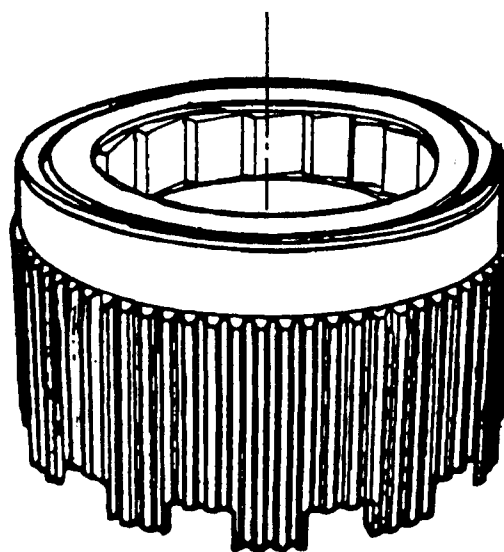
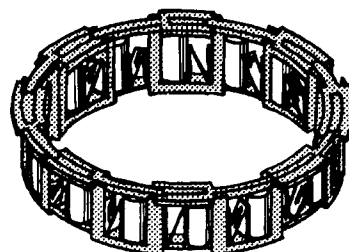


CAUTION

IF THE ROLLER CLUTCH IS INSTALLED IN THIS DIRECTION, THE REVERSE HUB WILL FREEWHEEL IN BOTH DIRECTIONS.

***"CORRECT"
INSTALLATION***

NOTE TABS ON
TOP OUTER EDGE



DISCARD BOTH SNAP RINGS. THEY ARE NOT USED WITH THE PLASTIC ROLLER CLUTCH

Figure 36



FORD E4OD NEW OVERDRIVE ROLLER CLUTCH KIT TO REPLACE OVERDRIVE SPRAG ASSEMBLY

Beginning on August 11, 1994, *all* 1995 model E4OD transmissions were produced with a new design "Overdrive Roller Clutch", instead of the previous "Overdrive Sprag Assembly".

The previous design Overdrive Sprag (E9TZ-7A089-A) *is no longer available*. The previous part number will now supercede to one of the part numbers listed below under "Service Information", as there is one number for F-Super Duty and Motorhomes and another number for all others. The new design "Overdrive Roller Clutch Service Kit" will retro-fit back on *all* previous models (See Figure 37).

However, ATSG recommends that the "Overdrive Roller Clutch Kit" be installed on all previous models, *only if you have also installed the "Ball Bearing Center Support Kit"*, available under OEM part number F4TZ-7A130-B. Refer to the index in this manual for the Ball Bearing Center Support information and current part number information.

Use the following procedure to assemble and install the new design "Overdrive Roller Clutch Kit", as it comes in pieces, and does not include any installation instructions in the kit.

- (1) Place the new inner cam on a flat work surface with the "Undercut" on the inside diameter facing *up*, as shown in Figure 38.
- (2) Install the overdrive roller clutch assembly over the inner cam, *with the 9 locking tabs on the inner diameter facing down, and the three upper locking tabs facing up*, as shown in Figure 38.
- (3) Push the overdrive roller clutch assembly all the way down, as shown in Figure 39.
- (4) Install the snap ring into the groove in the outer race, as shown in Figure 40.
- (5) Install the outer race assembly over the overdrive roller clutch, by holding the inner cam and rotating the outer race in a clockwise direction, until fully seated, as shown in Figure 41.

NOTE: *With the outer race snap ring facing up, and the inner cam "undercut" facing up, the inner cam should freewheel in a counter-clockwise direction and lock clockwise, while holding the outer race. Refer to Figure 41.*

- (6) Install the completed Overdrive Roller Clutch Assembly into the overdrive ring gear, with the snap ring and the inner cam undercut, *facing up*, and install the outer race to ring gear snap ring, as shown in Figure 42.

SERVICE INFORMATION:

Overdrive Roller Clutch Service Kit, (All Except Super Duty and Motorhome) F5TZ-7A089-A
Overdrive Roller Clutch Service Kit, (7.5L F-Super Duty and Motorhome) F4TZ-7A089-A

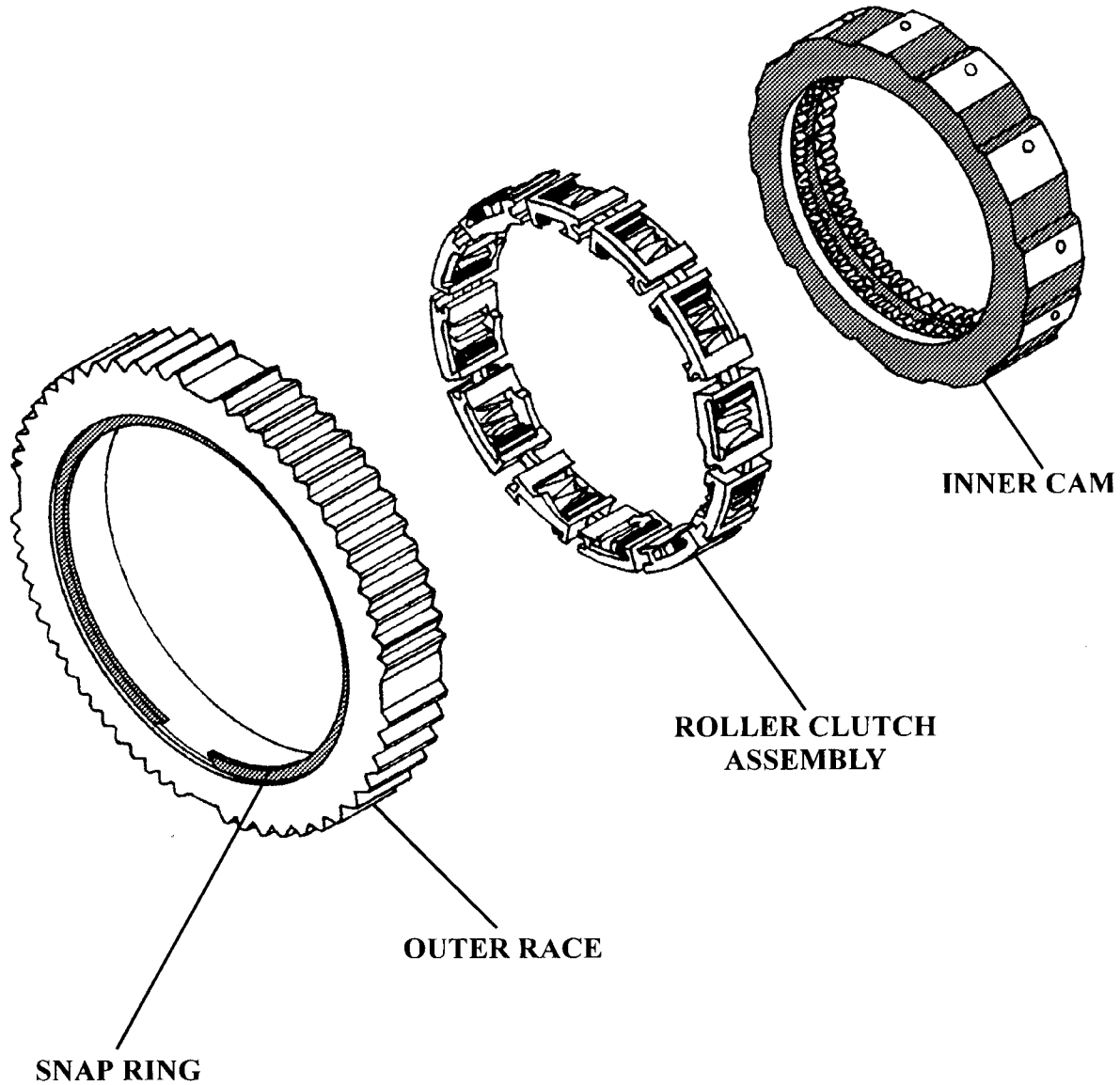
**OVERDRIVE ROLLER CLUTCH ASSEMBLY
PART NUMBER F5TZ-7A089-A**

Figure 37

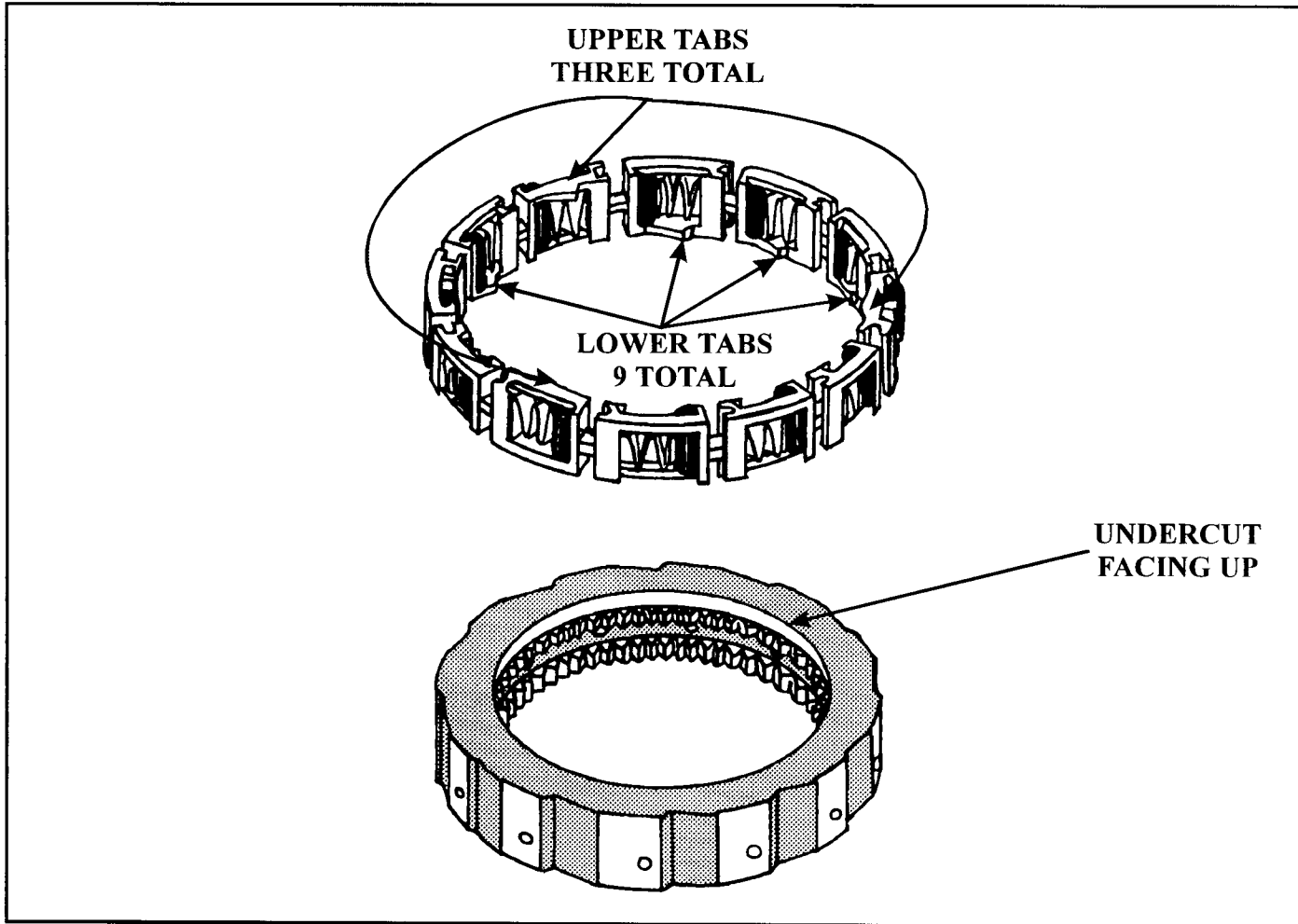


Figure 38

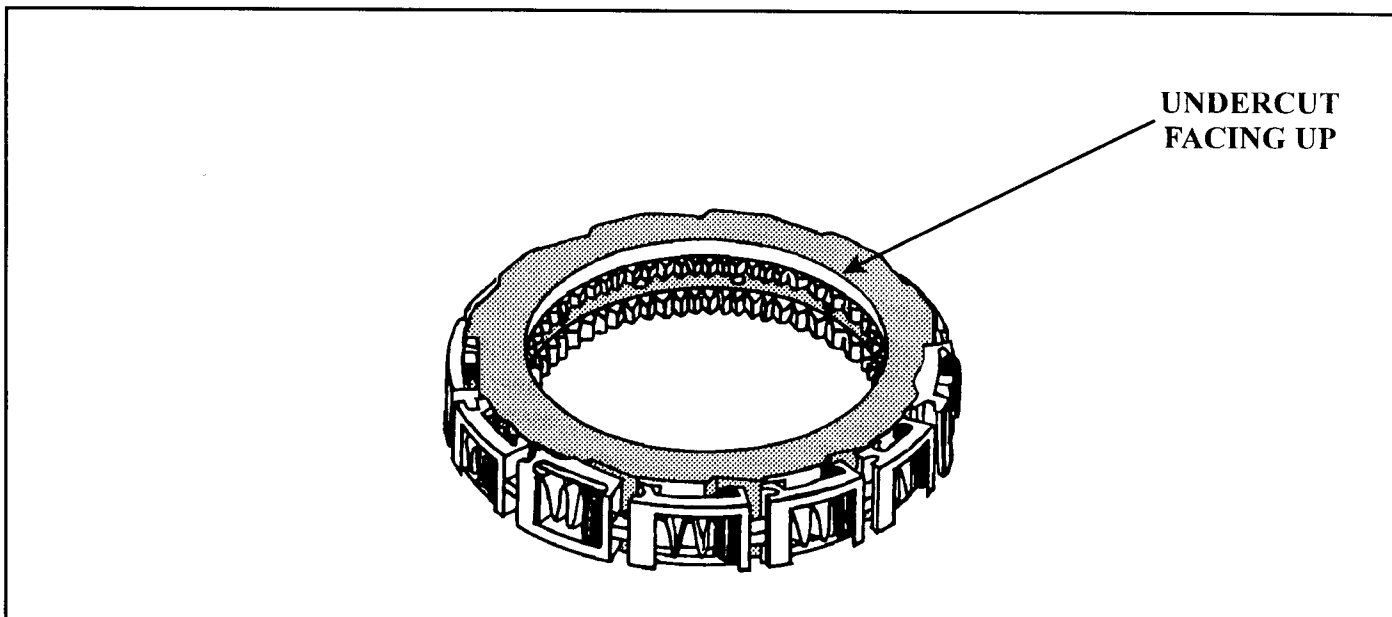


Figure 39

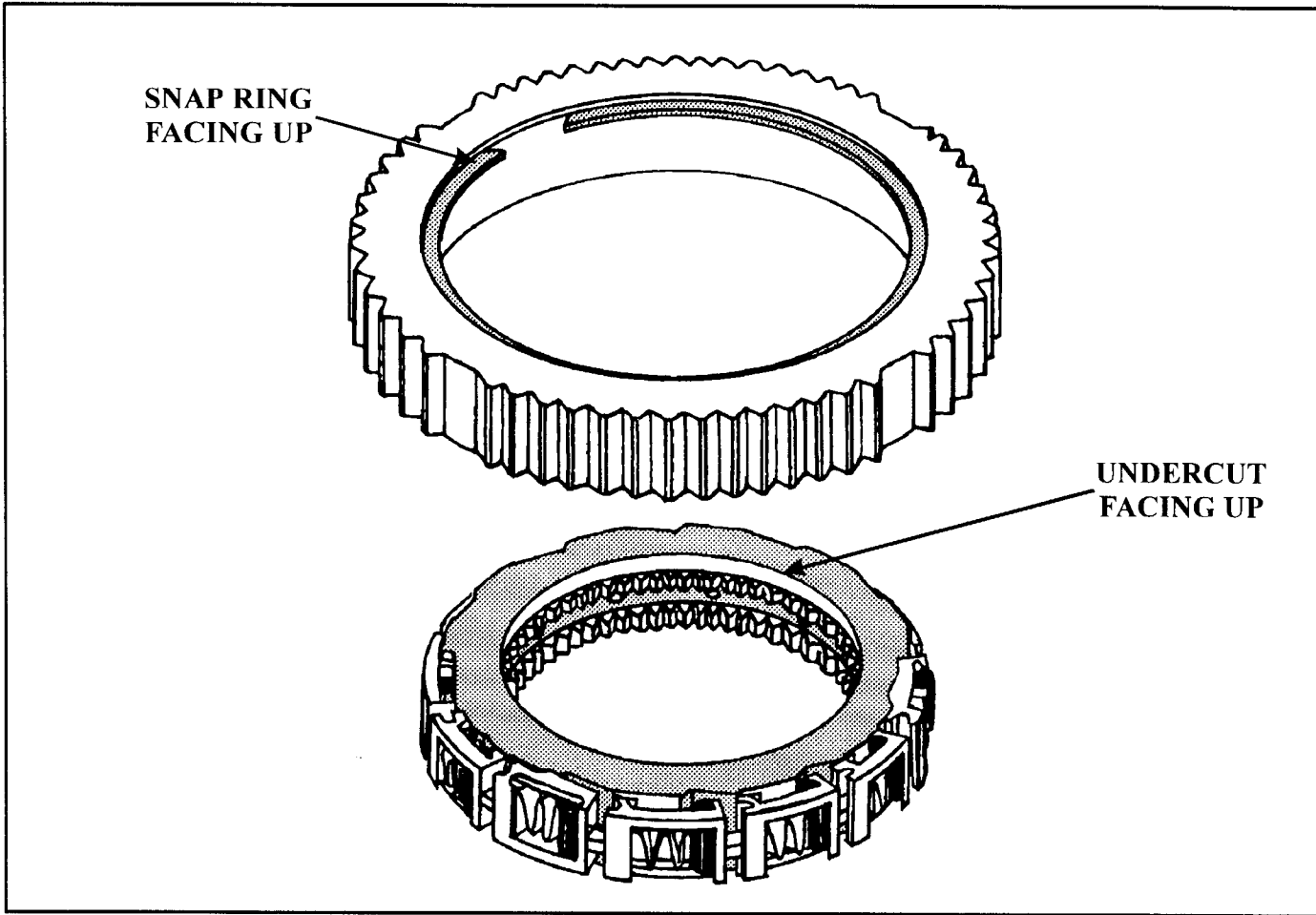


Figure 40

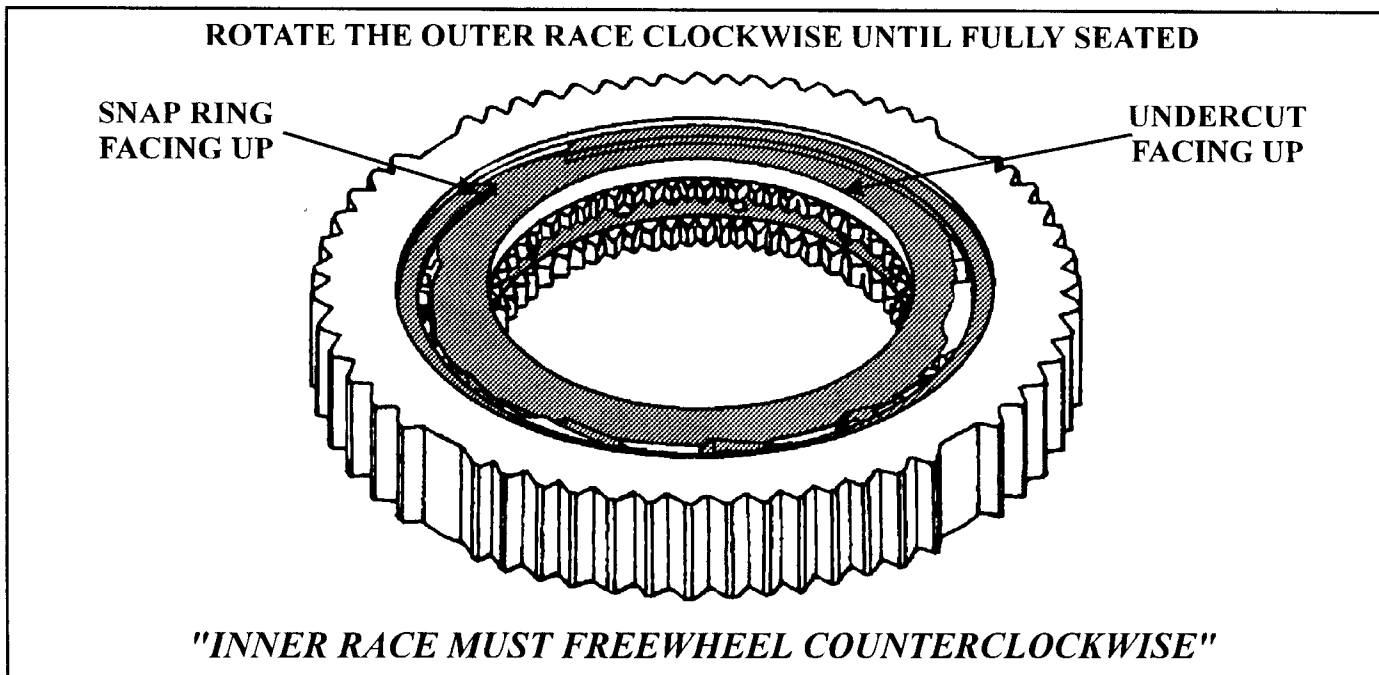


Figure 41
AUTOMATIC TRANSMISSION SERVICE GROUP

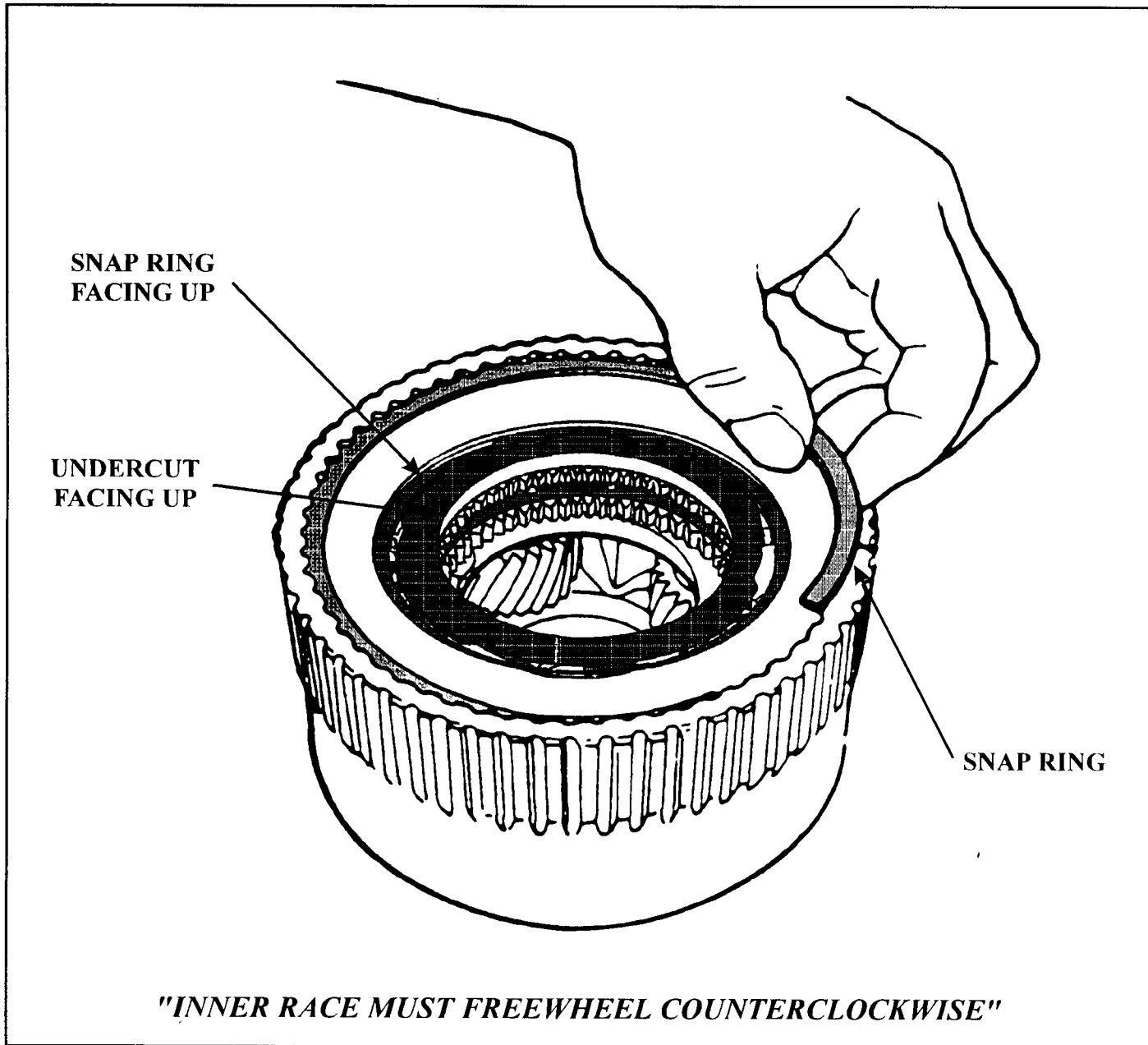


Figure 42



FORD E4OD NEW DESIGN CENTER SUPPORT SERVICE KIT WITH BALL BEARING

CHANGE: There is now available, from Ford Motor Co, a new design Center Support Service Kit with a ball bearing in the support. The new design service package is available under OEM part number F4TZ-7A130-B, and will back service all past model 89-94 E4OD transmissions only. The parts in this service kit are different dimensions than 1995 model year production parts. Refer to Figure 43 for service package kit contents.

REASON: Greatly increases transmission durability.

PARTS AFFECTED:

- (1) CENTER SUPPORT - Different machining dimensions on the inside bore, to accommodate an added ball bearing that will now support the overdrive center shaft. The new design ball bearing support can be identified as a "Service Part", by the letter "S" stamped on hub, in the location shown in Figure 44. The Service Kit Ball Bearing Center Support has different dimensions than the 1995 production ball bearing center support. Refer to Dimension "A" on the cutaway drawing shown in Figure 44.
- (2) OVERDRIVE CENTER SHAFT - Different machining dimensions on the center shaft to accommodate the added ball bearing, and the pilot on the center shaft has been removed. The new design Overdrive Center Shaft can be identified as a "Service Part", by the letter "S" stamped on the shaft in one of two locations, as shown in Figure 45. The Service Kit Overdrive Center Shaft has different dimensions than 1995 model year production center shaft. Refer to Dimensions "A" and "B" in the cutaway drawing shown in Figure 45.
Special Note: There is also an updated Overdrive Carrier and Input Shaft, available under OEM part number F4TZ-7B446-B, to help improve durability. Both pieces have different dimensions than the previous parts, as shown in Figure 48. The new overdrive carrier hub is 12mm (.472") shorter than the previous models, and the internal splines now run the full length of the hub which makes it stronger. The Input Shaft is also 12mm (.472") shorter than the previous models, to accommodate the new overdrive carrier, and has an I.D. groove cut in the shaft for identification (See Figure 48).
- (3) OUTPUT SHAFT - Small bushing *must* be removed and the orifice cup plug included in the service kit *must* be installed, to accommodate the removal of the pilot from the overdrive center shaft. This will now ensure that lube oil is directed to the proper areas. Refer to Figure 46 for the bushing removal and orifice cup plug installation.
The orifice cup plug in this service kit is different dimensions than the 1995 production models, and will fit *only* an output shaft that previously had the bushing.

Continued on next Page



Technical Service Information

PARTS AFFECTED: (Continued)

- (4) NO. 5 NEEDLE BEARING - Make certain the No. 5 Needle Bearing included in the service kit is installed with the service kit *regardless* of whether your unit had one or did not have one. Some 1994 model year transmissions were built with some or all of the parts that "Resemble" the parts in this service kit, and may or may not have a No. 5 needle bearing. Make certain that the No. 5 needle bearing from the service kit is installed. Refer to Figure 47 for proper installation of the needle bearing.

INTERCHANGEABILITY:

- (1) This Service Kit will service all past model E4OD transmissions 1989 thru 1994 model years, when used in it's entirety, and is highly recommended on *all* previous model E4OD units.
- (2) The parts in this Service Kit are different dimensions than 1995 model year production parts and *will not* interchange with 1995 model parts (See Figures 44 and 45).
- (3) Some 1994 model year transmissions were built with some or all of the parts that "Resemble" the parts in this service kit. When servicing these units, use all of the parts in the kit *except*, the orifice cup plug. These units already have a cup plug in the output shaft and it is a different diameter. The Service Kit orifice cup plug will fit *only* an output shaft that was previously equipped with a bushing (See Figure 46).
- (4) The Overdrive Carrier Assembly and Input Shaft are matching components and *must* be serviced as a package.

DO NOT MIX LONG AND SHORT COMPONENTS!

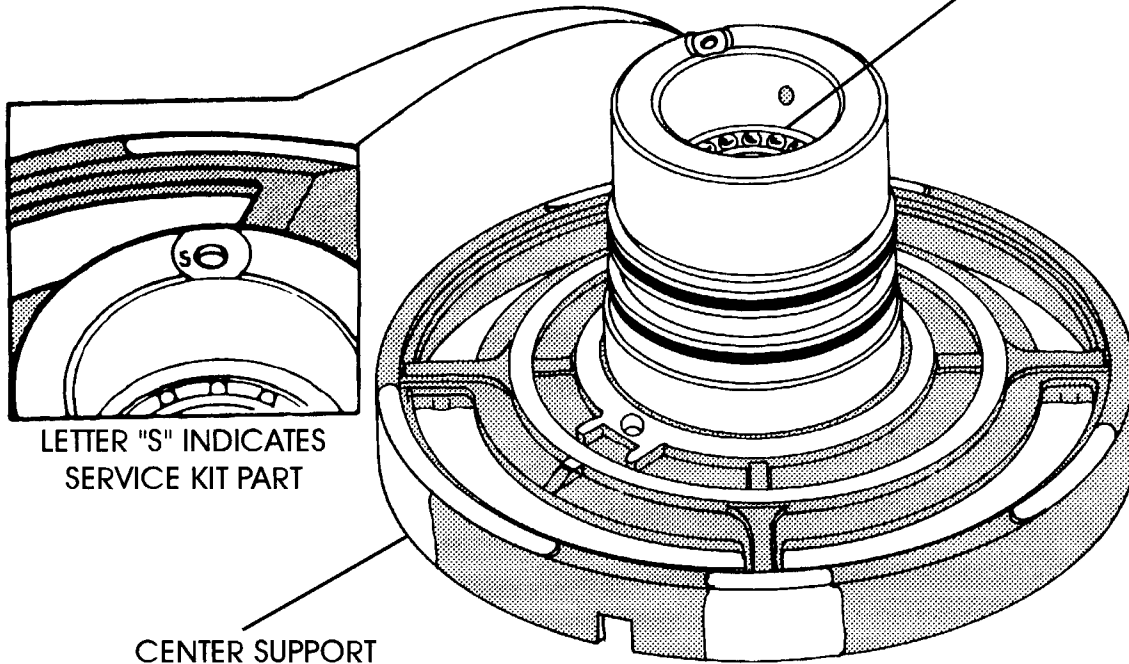
Refer to Figure 49 to ensure that you have built the unit with matching components. The Input Shaft must extend 1-1/2" past the end of the oil pump stator, if you used the correct input shaft and overdrive carrier. Refer to Figure 49 for proper assembly dimensions.

SERVICE INFORMATION:

Ball Bearing Center Support Kit (Yellow Dot)	F4TZ-7A130-B
Overdrive Carrier/Input Shaft Service Kit	F4TZ-7B446-B

F4TZ-7A130-B SERVICE KIT CONTENTS

BALL BEARING



THE LETTER "S" COULD BE IN EITHER LOCATION. THE "S" INDICATES SERVICE KIT PART

ORIFICE CUP PLUG (ORIFICE SIZE .086")



OVERDRIVE CENTER SHAFT

NUMBER FIVE NEEDLE BEARING

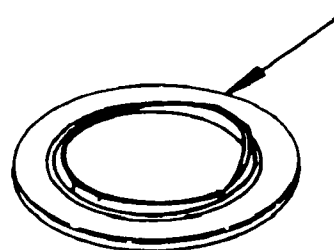
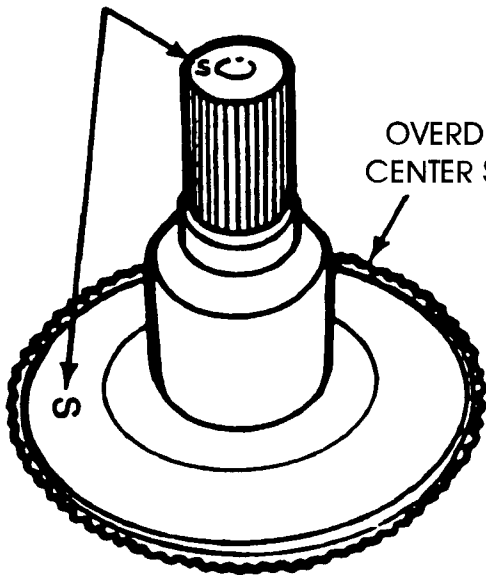


Figure 43

AUTOMATIC TRANSMISSION SERVICE GROUP

BALL BEARING CENTER SUPPORT

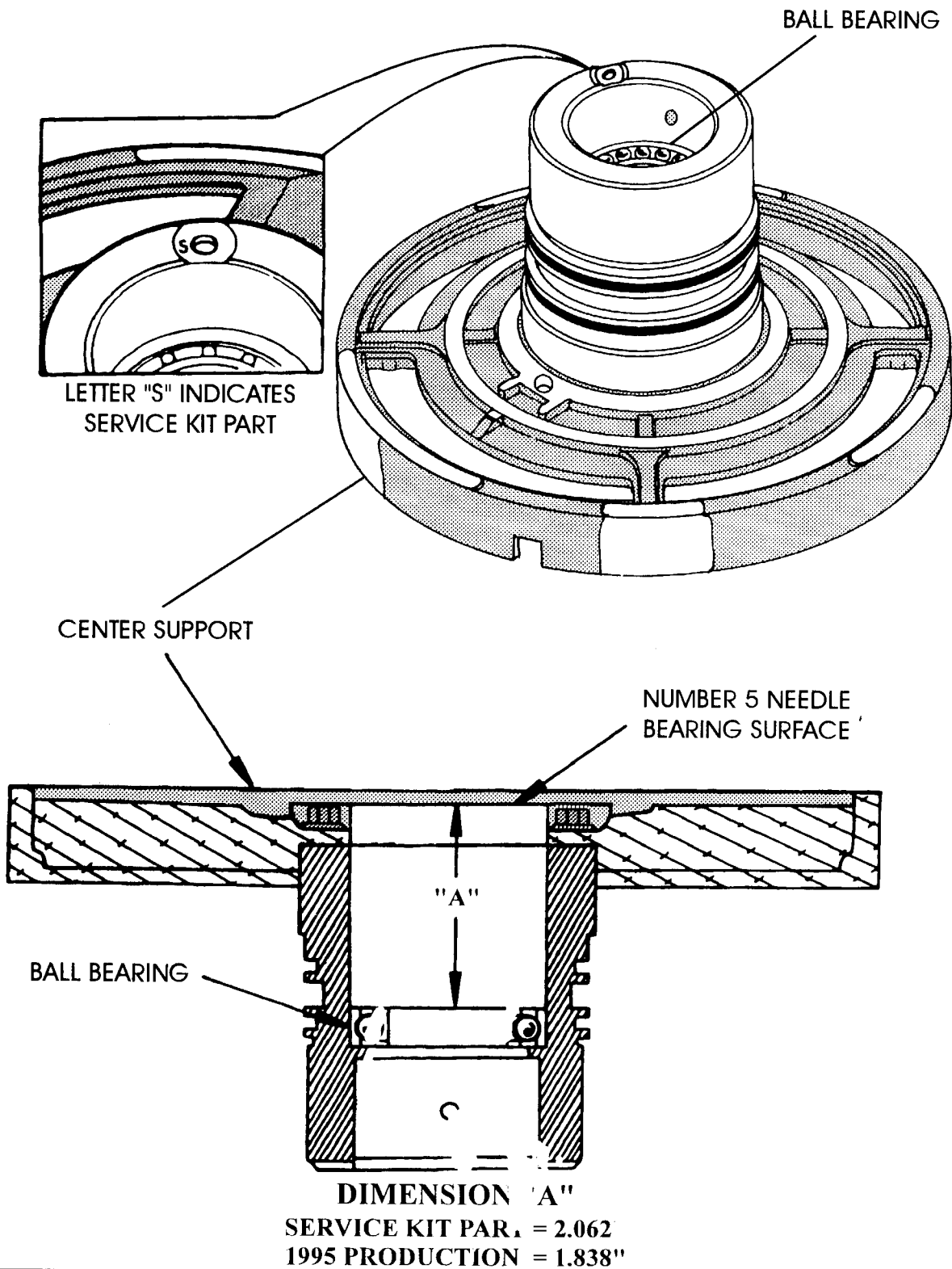


Figure 44
AUTOMATIC TRANSMISSION SERVICE GROUP

OVERDRIVE CENTER SHAFT

DIMENSION "A"

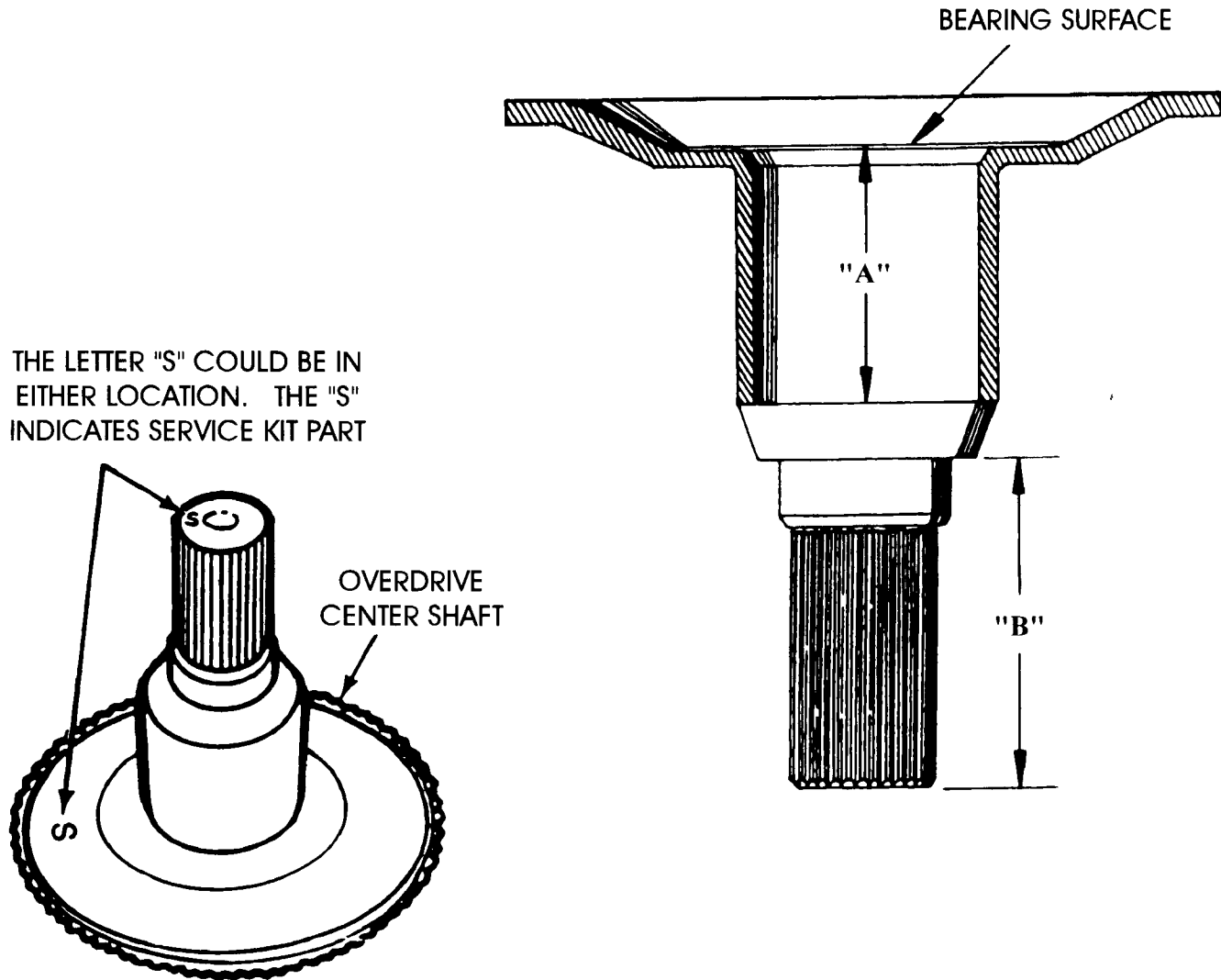
SERVICE KIT PART = 1.938"

1995 PRODUCTION = 1.710"

DIMENSION "B"

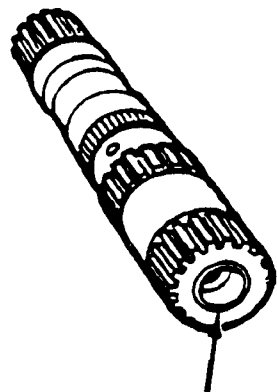
SERVICE KIT PART = 2.368"

1995 PRODUCTION = 2.592"

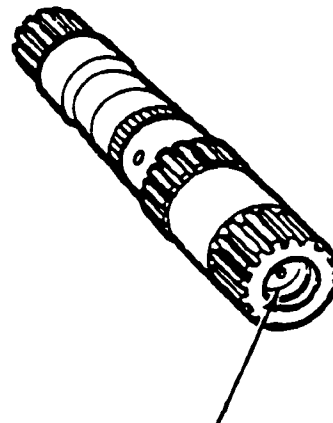


THE LETTER "S" COULD BE IN EITHER LOCATION. THE "S" INDICATES SERVICE KIT PART

Figure 45

**OUTPUT SHAFT AND
ORIFICE CUP PLUG**

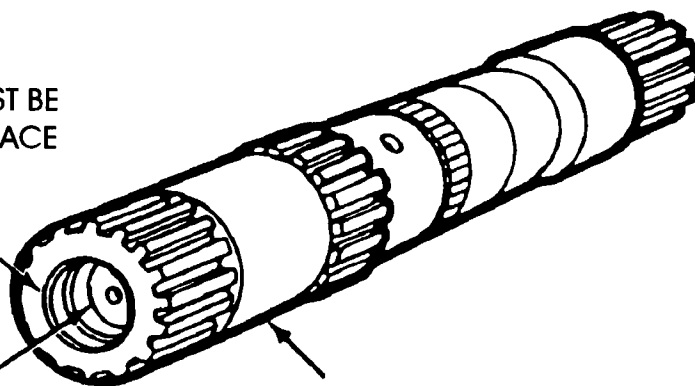
REMOVE THE
ORIGINAL BUSHING



INSTALL THE ORIFICE CUP
PLUG FROM THE SERVICE KIT

THE ORIFICE CUP PLUG MUST BE
INSTALLED BELOW THIS SURFACE

ORIFICE CUP PLUG
(ORIFICE SIZE .086")



OUTPUT SHAFT

NOTE: THE ORIFICE CUP PLUG IN THIS SERVICE KIT IS DIFFERENT DIMENSIONS THAN 1995 PRODUCTION MODELS, AND WILL FIT *ONLY* AN OUTPUT SHAFT THAT HAS A BUSHING.

Figure 46

AUTOMATIC TRANSMISSION SERVICE GROUP

NUMBER 5 NEEDLE BEARING PROPER INSTALLATION

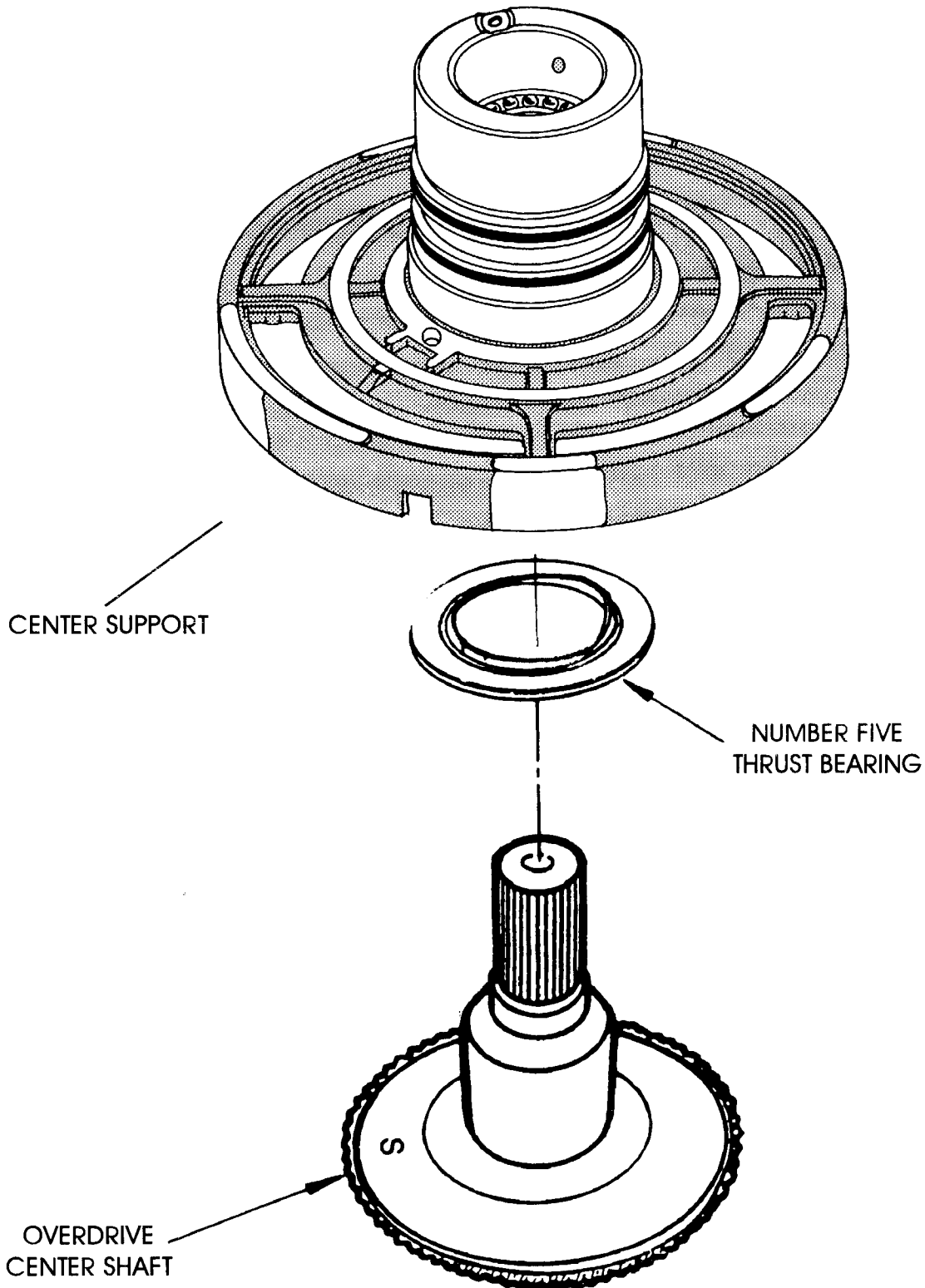


Figure 47
AUTOMATIC TRANSMISSION SERVICE GROUP

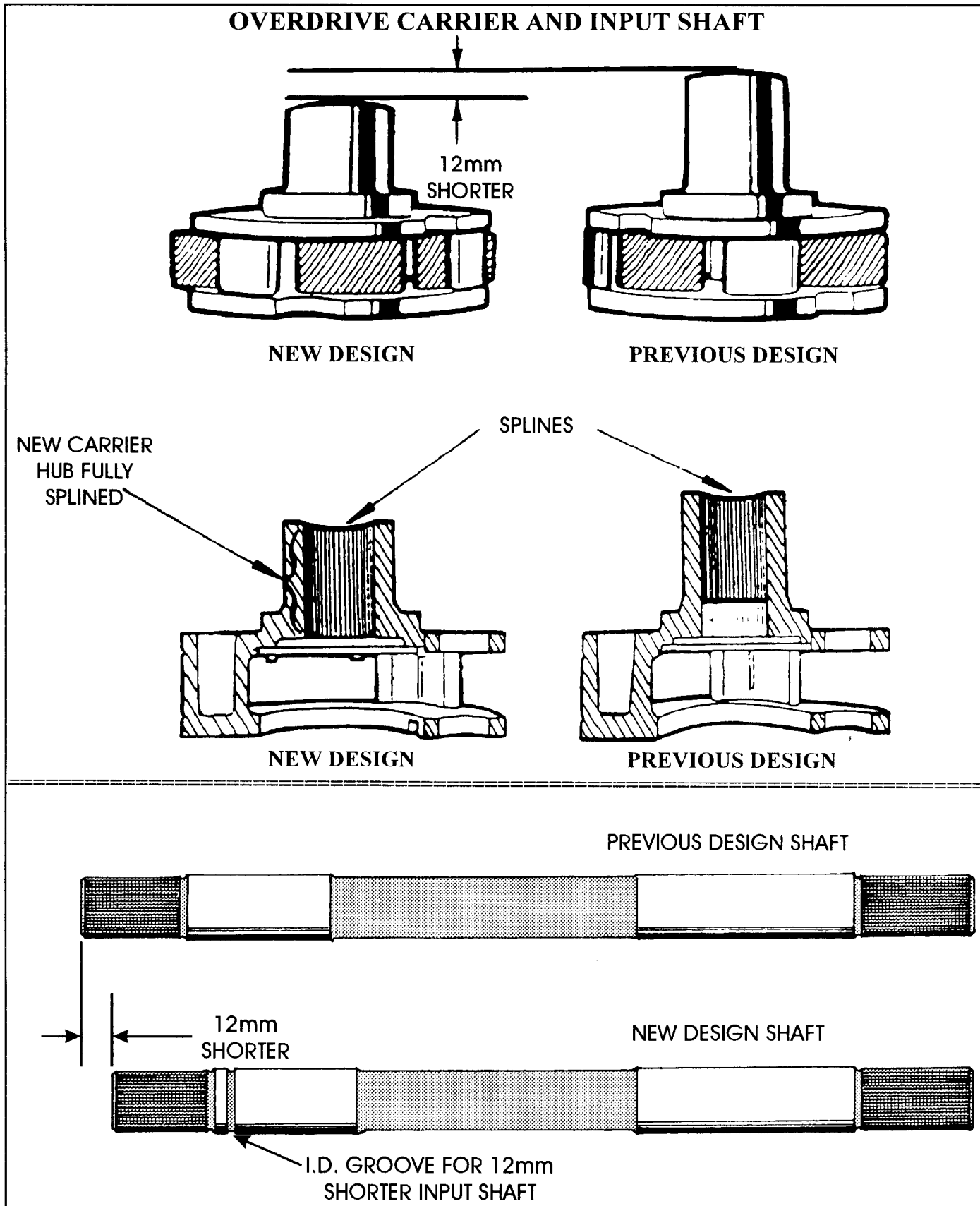
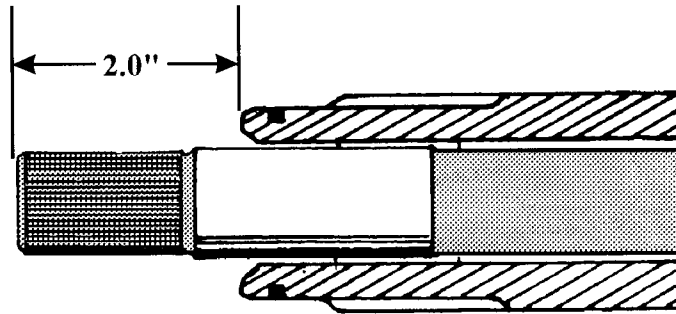


Figure 48
AUTOMATIC TRANSMISSION SERVICE GROUP

OVERDRIVE CARRIER AND INPUT SHAFT USAGE

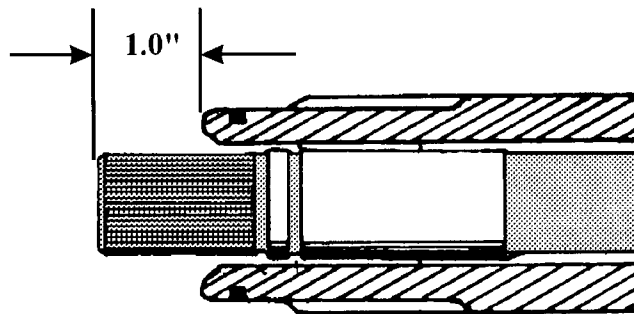
"INCORRECT"

PREVIOUS (LONG) INPUT SHAFT USED
WITH NEW DESIGN OVERDRIVE CARRIER



"INCORRECT"

NEW DESIGN (SHORT) INPUT SHAFT USED
WITH PREVIOUS DESIGN OVERDRIVE CARRIER



"CORRECT USAGE"

THE INPUT SHAFT MUST EXTEND 1.5" PAST THE END OF THE PUMP STATOR
IF THE CORRECT INPUT SHAFT AND OVERDRIVE CARRIER WERE USED

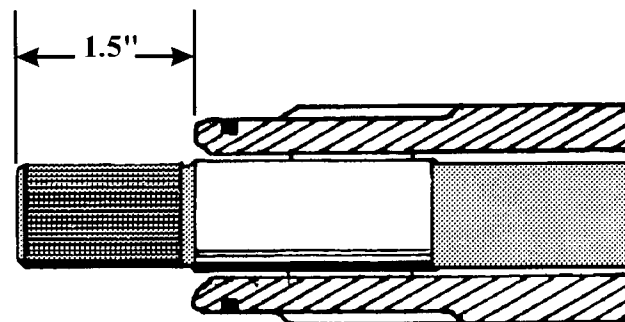


Figure 49

HERE IT IS!!!

THE MOST COMPLETE LINE OF
DOMESTIC AND IMPORT MANUALS
ATSG TECHNICAL BULLETINS FROM 1986 - 1995
AND OUR SEMINAR BOOKS FROM 1988 - 1995
ALL IN THE PALM OF YOUR HAND



Are you tired of looking through piles of technical information for a bulletin or manual and not remembering where you saw it last? The paper chase is over. ATSG now has technical bulletins 1986 - 1995, most Domestic & Import manuals on CD-ROM. Search for information first by manufacturer then by transmission type, its never been easier!! At the touch of a button you can:

- SEARCH FOR INFORMATION QUICKLY
- SAVE PERSONAL NOTES DIRECTLY ON THE PAGE FOR FUTURE REFERENCE
- PRINT OR FAX SPECIFIC PAGES OR COMPLETE DOCUMENTS

Don't waste any more valuable time searching through piles and piles of paper. Order the ATSG CD-ROM NOW!!!

FOR MORE INFORMATION CALL
(800) 245-7722



**FORD E4OD
NEW DESIGN CAST IRON
OVERDRIVE CARRIER**

CHANGE: There is now available from Ford Motor Company, a new design Overdrive Planetary Carrier that is made out of cast iron and available under part number F5TZ-7B446-A.

REASON: Greatly increased durability of the Overdrive Carrier.

PARTS AFFECTED:

- (1) OVERDRIVE PLANETARY CARRIER - New design is made out of cast iron and is the shorter design that requires the new design input shaft (See Figure 50).
- (2) INPUT SHAFT - Now 12mm shorter than the previous design shaft to accommodate the new design overdrive planetary carrier, and is required with the new carrier (See Figure 50).

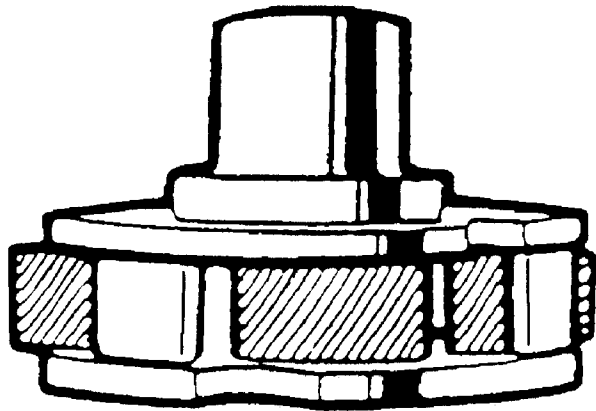
INTERCHANGEABILITY:

The new design cast iron Overdrive Planetary Carrier will back service all models to 1989, but the new design Input Shaft is required to be used with it (See Figure 50).

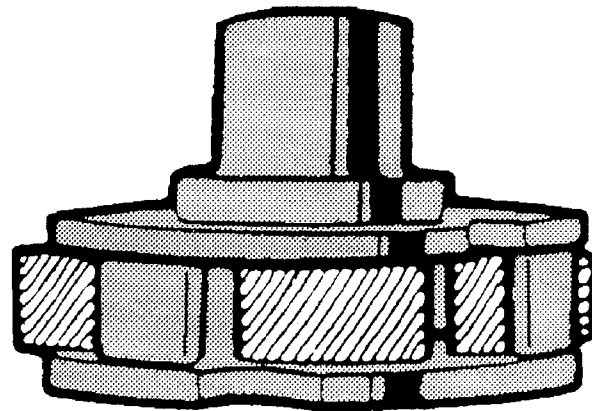
SERVICE INFORMATION:

Overdrive Planetary Carrier (Cast Iron)	F5TZ-7B446-A
Input Shaft (Short with I.D. Groove)	F4TZ-7017-D

NEW DESIGN CAST IRON OVERDRIVE CARRIER



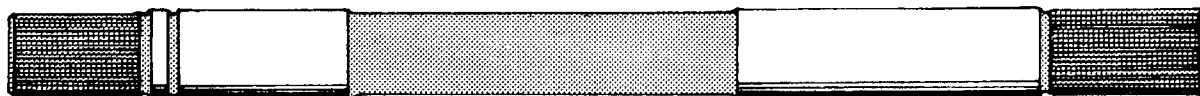
**PREVIOUS DESIGN ALUMINUM
OVERDRIVE CARRIER**



**NEW DESIGN CAST IRON
OVERDRIVE CARRIER
F5TZ-7B446-A**

**THE NEW DESIGN CAST IRON OVERDRIVE CARRIER IS THE SHORTER
VERSION OF THE PREVIOUS CARRIERS, AND *MUST* BE USED WITH THE
SHORT INPUT SHAFT WITH I.D. GROOVE, AS SHOWN BELOW.**

**CAST IRON OVERDRIVE CARRIER CAN BE
USED ONLY WITH THE SHORT INPUT SHAFT**



**I.D. GROOVE TO IDENTIFY THE
12mm SHORTER INPUT SHAFT
F4TZ-7017-D**

Figure 50



**FORD E4OD
REVISED DIRECT CLUTCH HOUSING
FOR 1995 MODELS**

CHANGE: Beginning at the start of production for the 1995 model year, all E4OD transmissions were built with a revised Direct Clutch Housing (Intermediate Brake Drum) as shown in Figure 51.

REASON: Calibration concerns and changes for the 1995 model year.

PARTS AFFECTED:

(1) DIRECT CLUTCH HOUSING - 1995 models now have only *one* direct clutch apply pressure feed hole, instead of the *two* feed holes found in previous models (See Figure 51).

INTERCHANGEABILITY:

Usage of the revised 1995 Direct Clutch Housing with one feed hole, into any of the previous model units, may result in 2-3 shift concerns and/or reverse engagement concerns.

SERVICE INFORMATION:

89-94 Direct Clutch Housing (2 Feed Holes - 3/4 Clutch)	E9TZ-7D044-A
1995 Direct Clutch Housing (1 Feed Hole - 3/4 Clutch)	F5TZ-7D044-A
1995 Direct Clutch Housing (1 Feed Hole - 5 Clutch)	F5TZ-7D044-B

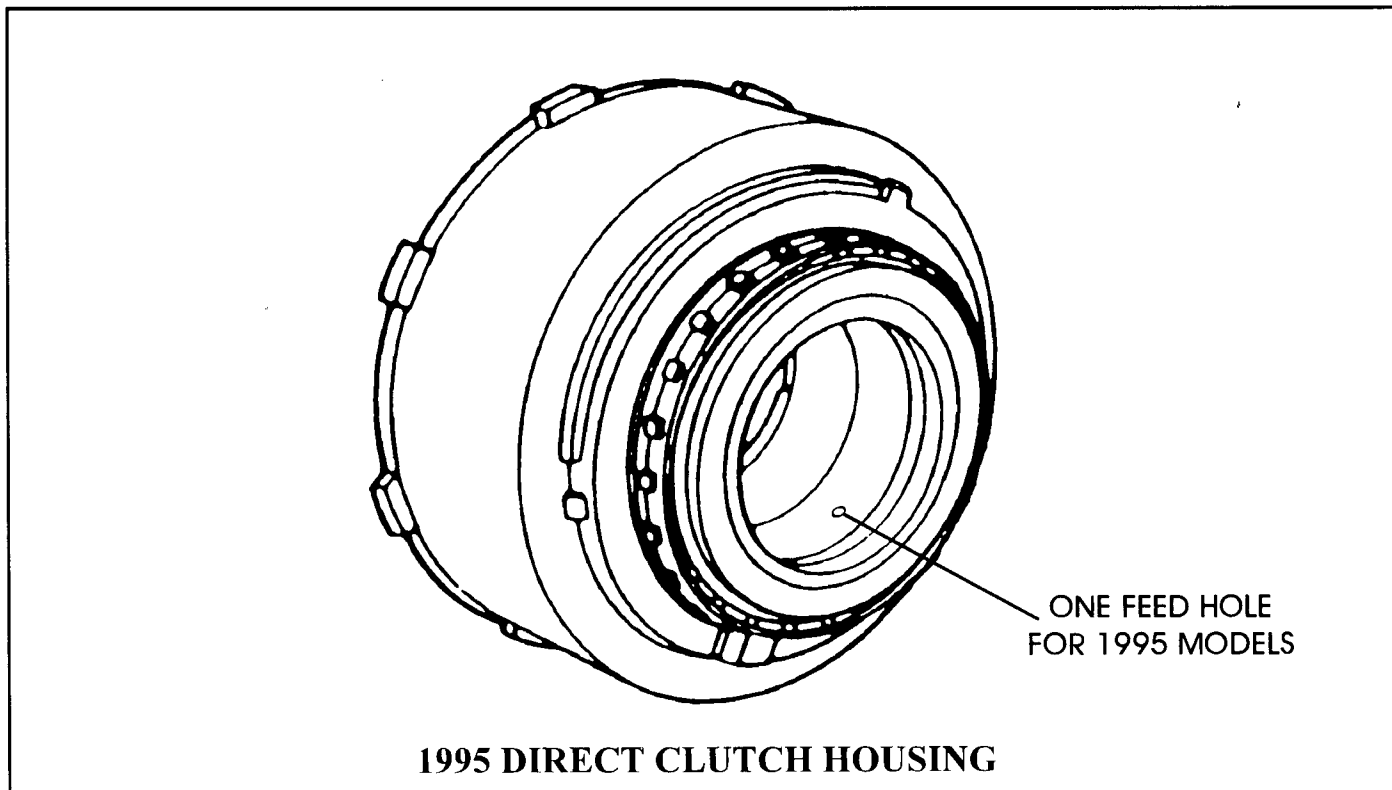


Figure 51



**FORD E4OD
NEW DESIGN SOLENOID PACK FOR 1995
VEHICLE HARNESS WILL NOT CONNECT
TO A NEW SOLENOID PACK**

CHANGE: Beginning at the start of production for 1995, all models of the E4OD transmission were produced using a new design solenoid pack, that will not interchange with previous models, as the internal diodes have been eliminated and put into the PCM (See Figure 54)

REASON: New design vehicle harness connector with grommet installed, to eliminate contamination from water and road debris, that may cause corrosion.

PARTS AFFECTED:

- (1) **SOLENOID PACK** - New design solenoid assembly case connector to accommodate the new design vehicle harness connector. Refer to Figure 52 for identification of the previous design and the new design solenoid assemblies.

NOTE: The plastic sleeve incorporated in the previous design solenoid pack has been eliminated on the new design solenoid pack (See Figures 52 and 53). This plastic sleeve will sometimes remain on the vehicle harness connector when it is disconnected. If a new solenoid pack is installed (which includes sleeve), it will be impossible to reconnect the vehicle harness to the solenoid pack until the old sleeve is removed from vehicle harness connector. Refer to Figure 53.

INTERCHANGEABILITY:

The previous design solenoid assembly will fit *only* 1989-1994 model vehicles, and the new design solenoid assembly will fit *only* 1995-UP models.

They will not interchange because in 1995 models the diodes for the solenoids were moved out of the solenoid pack and placed into the PCM (See Figure 54).

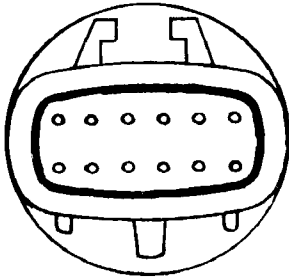
**IF A 1995 SOLENOID PACK IS USED ON 1989-1994 MODEL,
YOU WILL HAVE NO DIODE PROTECTION!**

SERVICE INFORMATION:

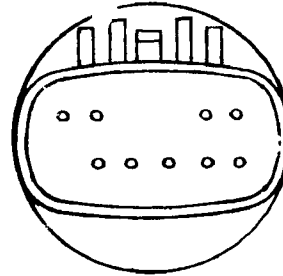
Solenoid Assembly, 1989-1994 Models Only	E9TZ-7G391-A
Solenoid Assembly, 1995-UP Models Only	F5TZ-7G391-A

E4OD SOLENOID PACK DIFFERENCES

PREVIOUS DESIGN
1989-1994 MODELS



NEW DESIGN
1995-UP MODELS



VIEW LOOKING INTO SOLENOID CASE CONNECTOR

THERE IS NO SLEEVE ON 1995 SOLENOID PACK

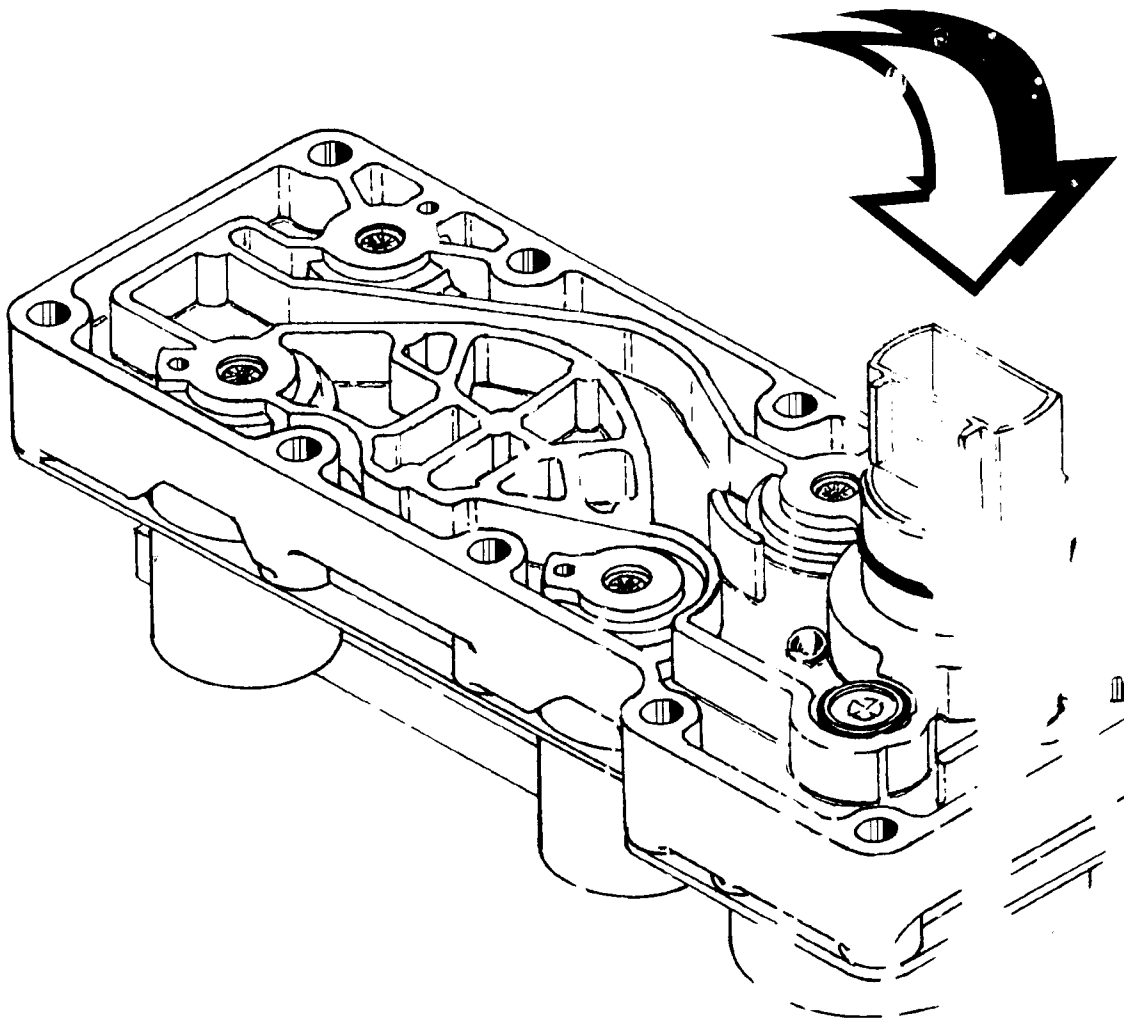
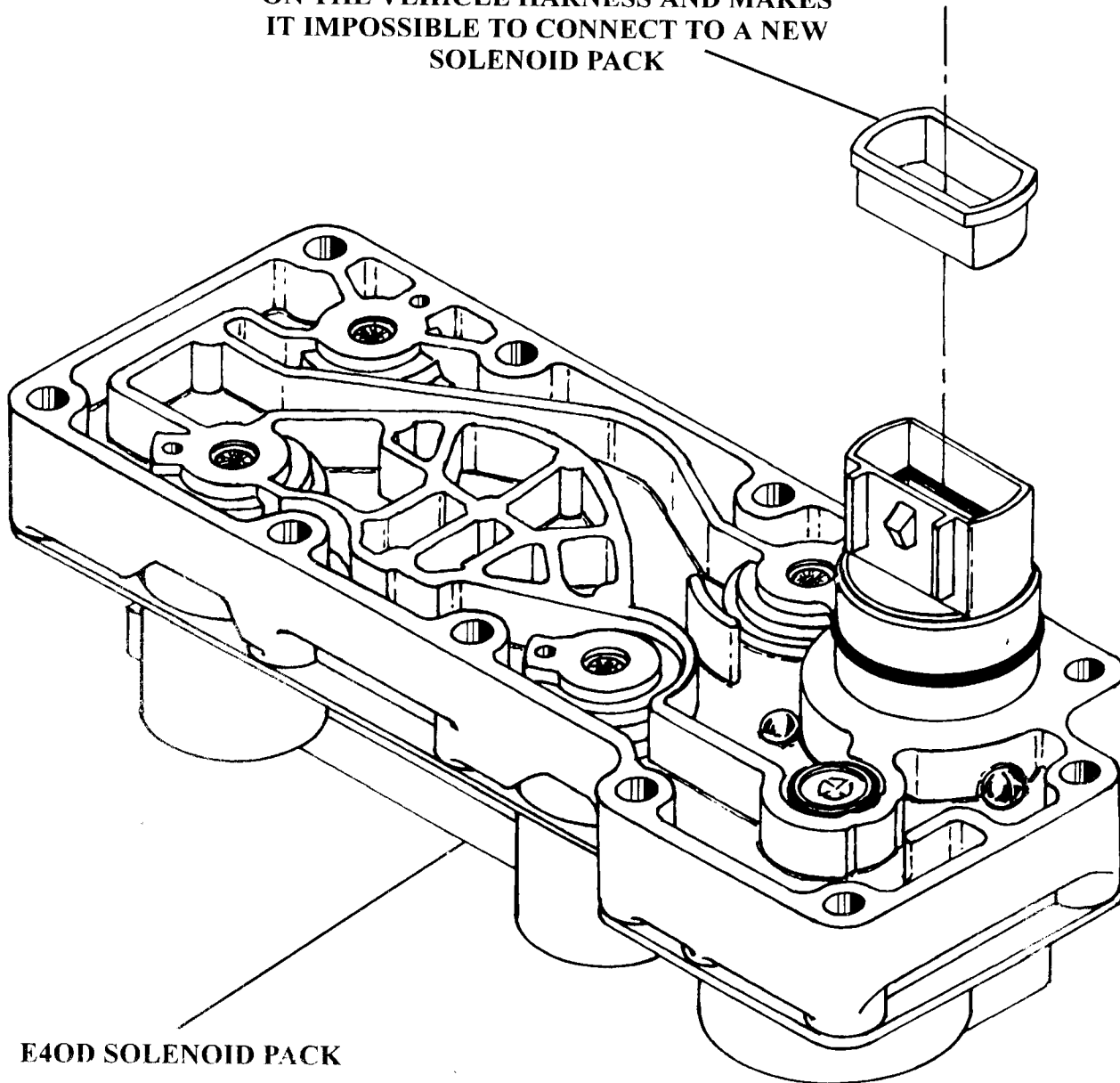


Figure 52

1989-1994 SOLENOID PACK

**PLASTIC SLEEVE SOMETIMES REMAINS
ON THE VEHICLE HARNESS AND MAKES
IT IMPOSSIBLE TO CONNECT TO A NEW
SOLENOID PACK**



E4OD SOLENOID PACK

Figure 53

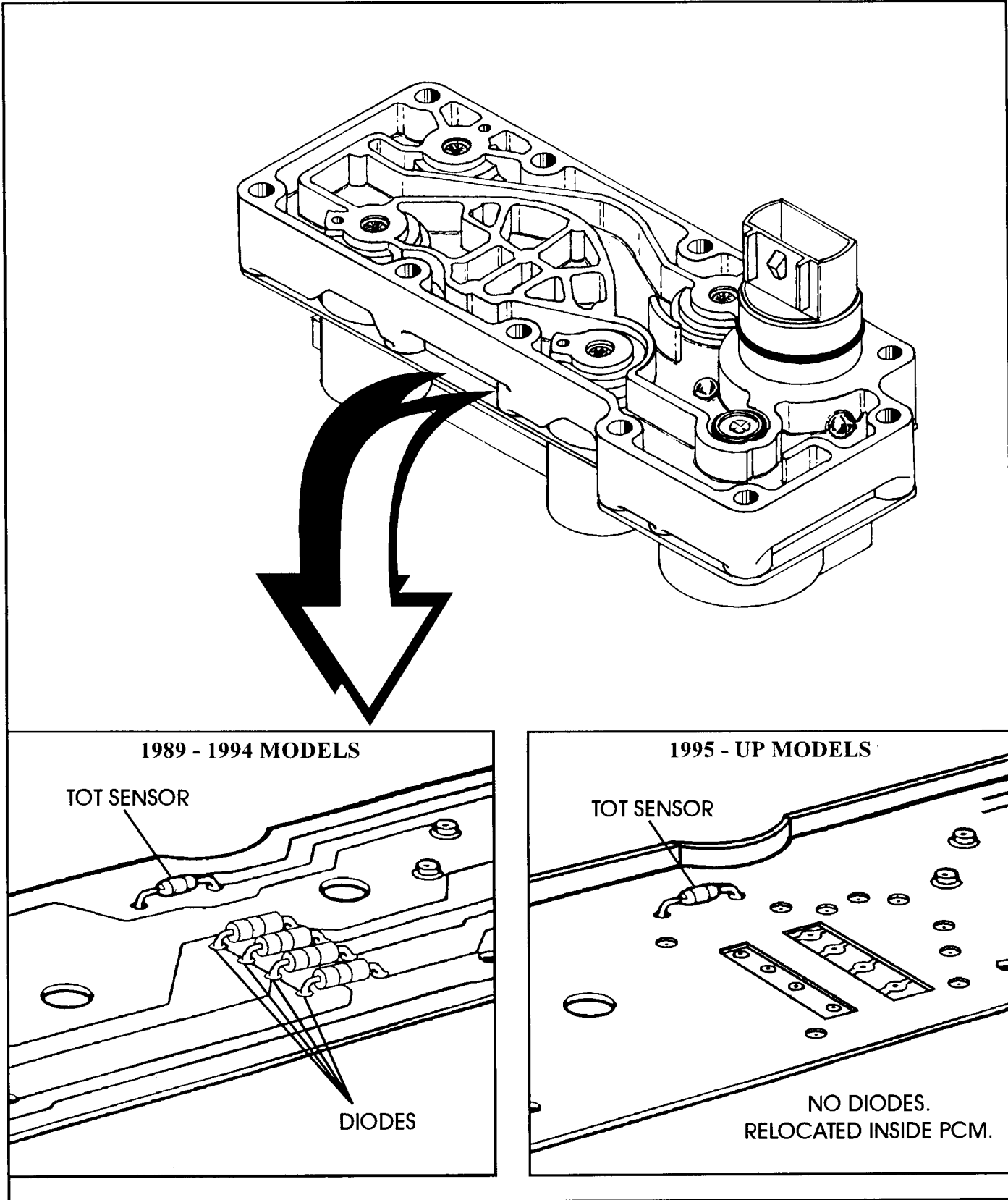


Figure 54



Technical Service Information

Notes



**FORD E4OD
NEW DESIGN FRONT PUMP
FOR 1995 MODELS**

CHANGE: Beginning at the Start Of Production for all 1995 model E4OD transmissions, Ford Motor Co. introduced an increased displacement Front Pump Assembly, 1.70 cu in/rev, versus 1.50 cu in/rev for previous models.

REASON: To provide additional flow for more robust converter clutch functions and additional lube flow, both of which will greatly increase transmission durability.

PARTS AFFECTED:

- (1) **FRONT PUMP BODY** - Gerotor bore has an increased diameter to accommodate the new design level outer gerotor. Previous outer gerotor diameter was 3.950" and the new design level outer gerotor diameter is 4.083". Refer to Figures 55 and 56. Also, the two holes in the suction cavity were increased from .312" to .400", as shown in Figures 55 and 56. Another way to identify the new pump body is with the "Rough Forging Number" F5TP-7A105-AA, and is found on the front seal side of the pump body. All of the oil passages in the new design Front Pump Body remained the same as previous years and are identified in Figure 58.
- (2) **OUTER GEROTOR** - The lobes on the Outer Gerotor changed from the previous 11 lobes to 10 lobes on the new design, to accommodate the changes on the inner gerotor. The diameter of the Outer Gerotor also changed from 3.950" to 4.083". Refer to Figures 55 and 56. The changes on both the inner and outer gerotor increased the cavity between the gerotors for increased pump volume, as shown in Figure 57.
- (3) **INNER GEROTOR** - The lobes on the Inner Gerotor changed from the previous 10 lobes to 9 lobes on the new design, to accommodate the changes on the outer gerotor. Refer to Figures 55 and 56. The changes on both the inner and outer gerotor increased the cavity between the gerotors for increased pump volume, as shown in Figure 57.
- (4) **FRONT PUMP COVER** - Received casting changes with added ribs in strategic places to increase torque retention when the two halves are torqued properly. The Pump Body to Pump Cover bolts should be torqued to 18-23 ft.lbs, with the alignment ring in place. The easiest way to identify the new design level Pump Cover is with the "Rough Forging Number" F5TP-7B324-AA, and is located on the back side of the Pump Cover. All of the oil passages in the new design Pump Cover remained the same as previous years and are identified in Figure 59. Internal pump cover passages are identified in Figure 60.

Continued on next Page.



Technical Service Information

INTERCHANGEABILITY:

- (1) The new design level Front Pump Assembly will retro-fit back to all previous models, when used as an assembly, and is recommended for all rebuilds. The new design Front Pump Assembly is available under OEM part number F5TZ-7A103-A.
- (2) *The new design level and previous design level gerotors will not interchange in any way.*

SERVICE INFORMATION:

Front Pump Assembly (New 1995 Design) F5TZ-7A103-A

**1989-1994 PUMP BODY AND GEARS
ROUGH FORGING NO. E9TP-7A105-BA
(PREVIOUS DESIGN)**

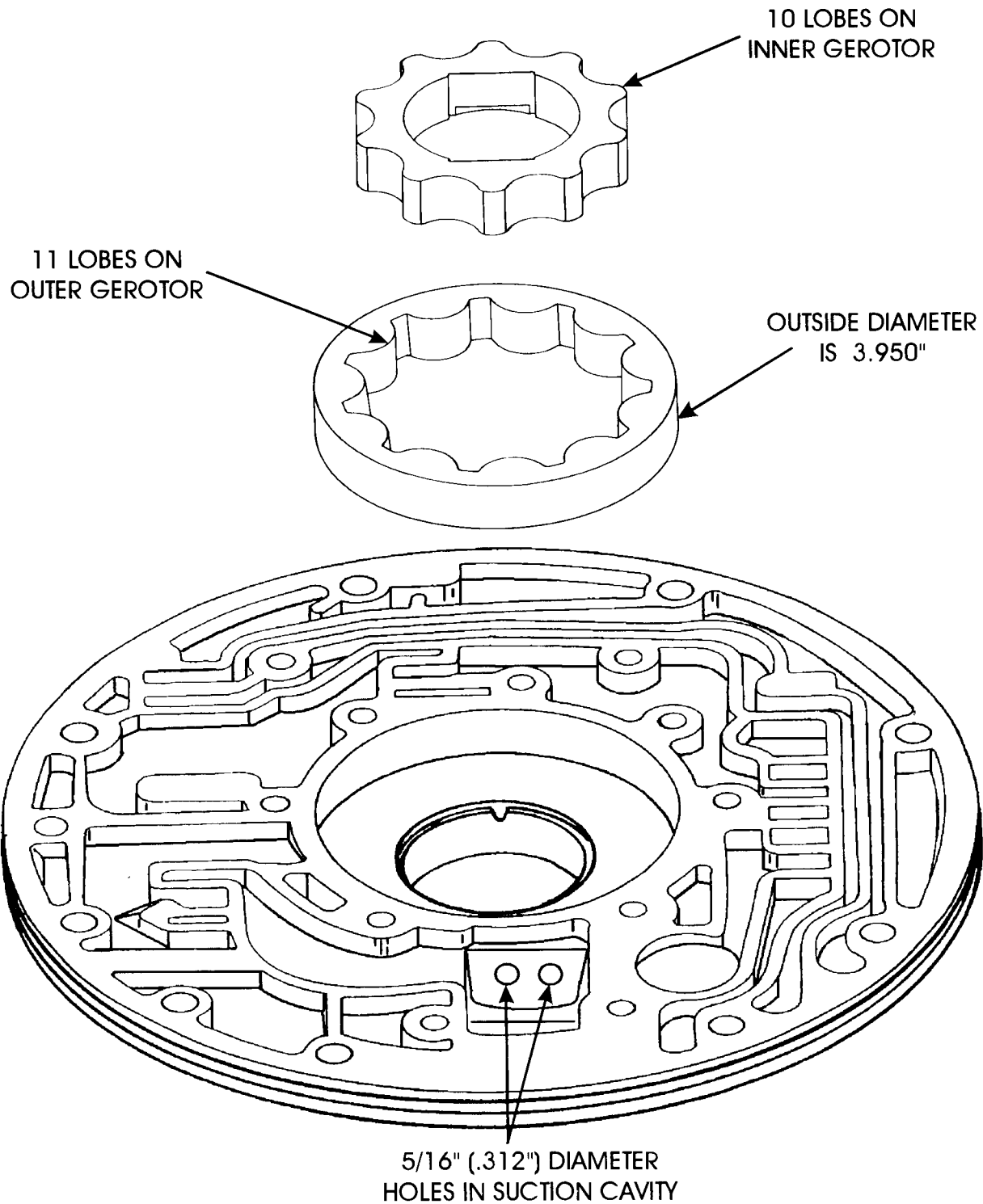


Figure 55

**1989-1994 PUMP BODY AND GEARS
ROUGH FORGING NO. F5TP-7A105-AA
(NEW DESIGN)**

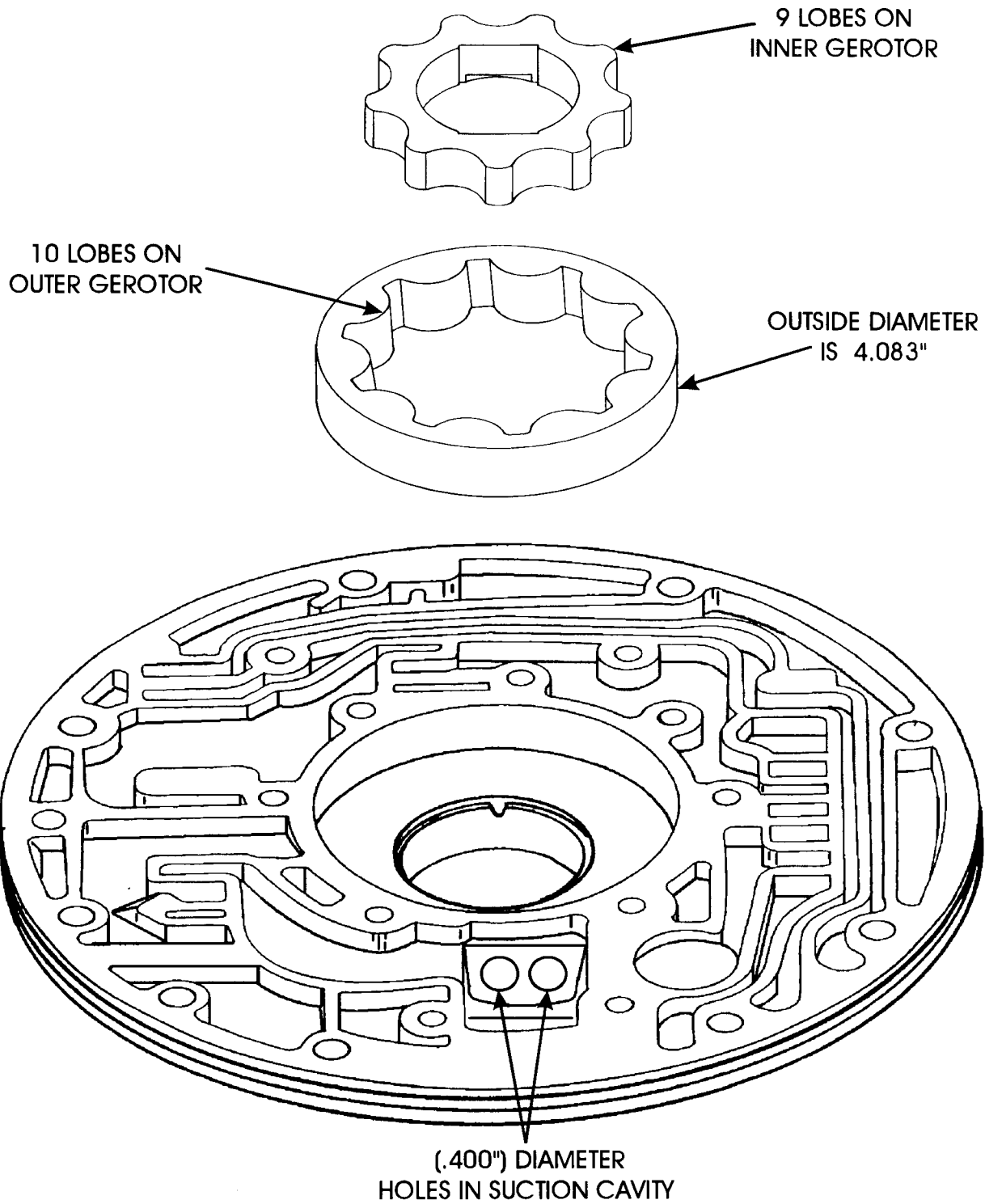


Figure 56

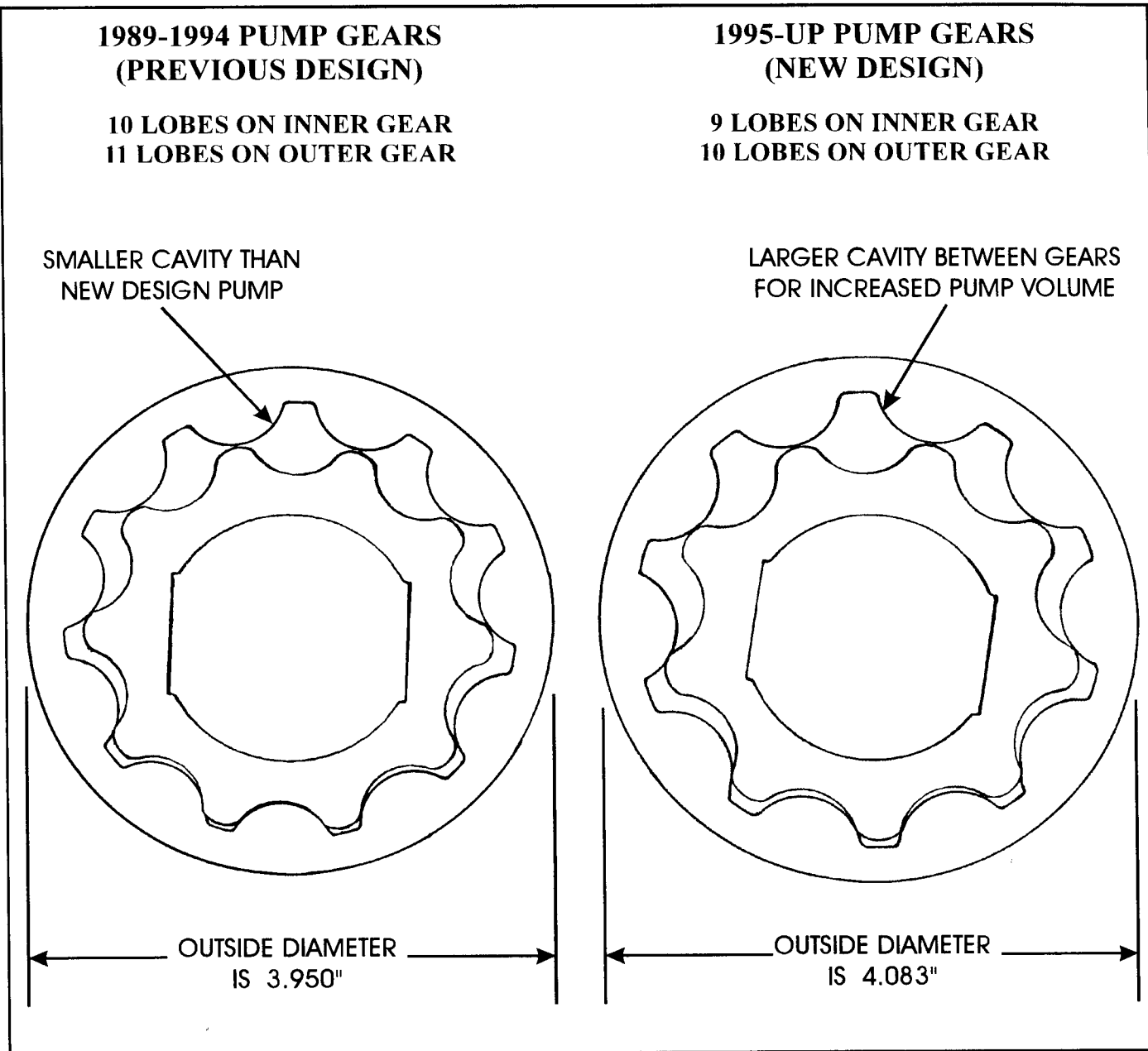
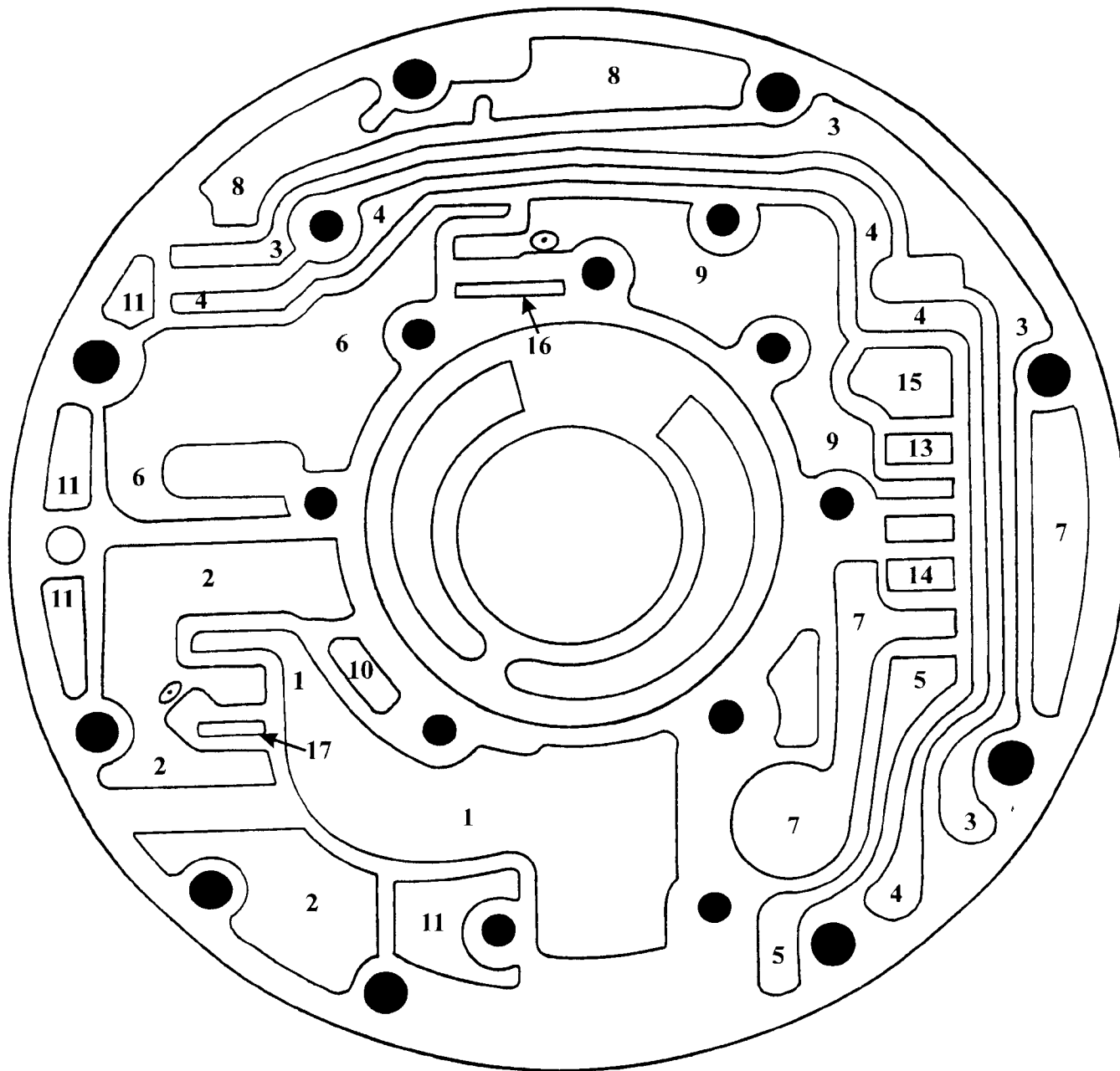


Figure 57

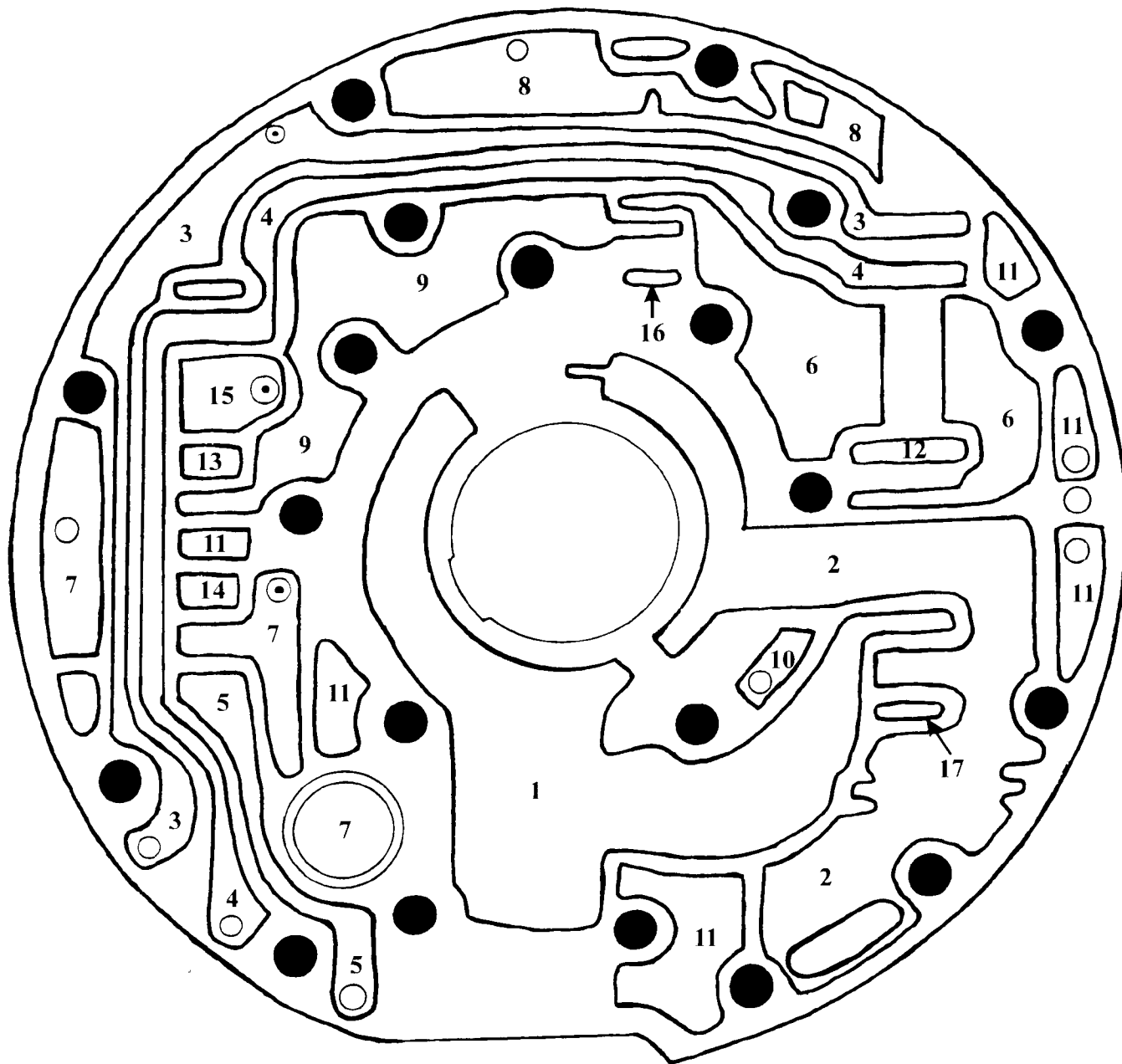
**E4OD PUMP BODY
OIL PASSAGE IDENTIFICATION**



- | | |
|---------------------------------|---------------------------------|
| 1. PUMP SUCTION | 10. PUMP SEAL DRAIN |
| 2. LINE PRESSURE | 11. VOID |
| 3. EPC BOOST | 12. EXHAUST |
| 4. MANUAL 1ST AND REVERSE BOOST | 13. CONVERTER RELEASE |
| 5. CONVERTER CLUTCH SIGNAL | 14. CONVERTER APPLY |
| 6. CONVERTER FEED | 15. RELEASE OIL EXHAUST |
| 7. TO COOLER | 16. TCC REGULATOR VALVE BALANCE |
| 8. VENT | 17. P.R. VALVE BALANCE |
| 9. REGULATED CONVERTER FEED | |

Figure 58

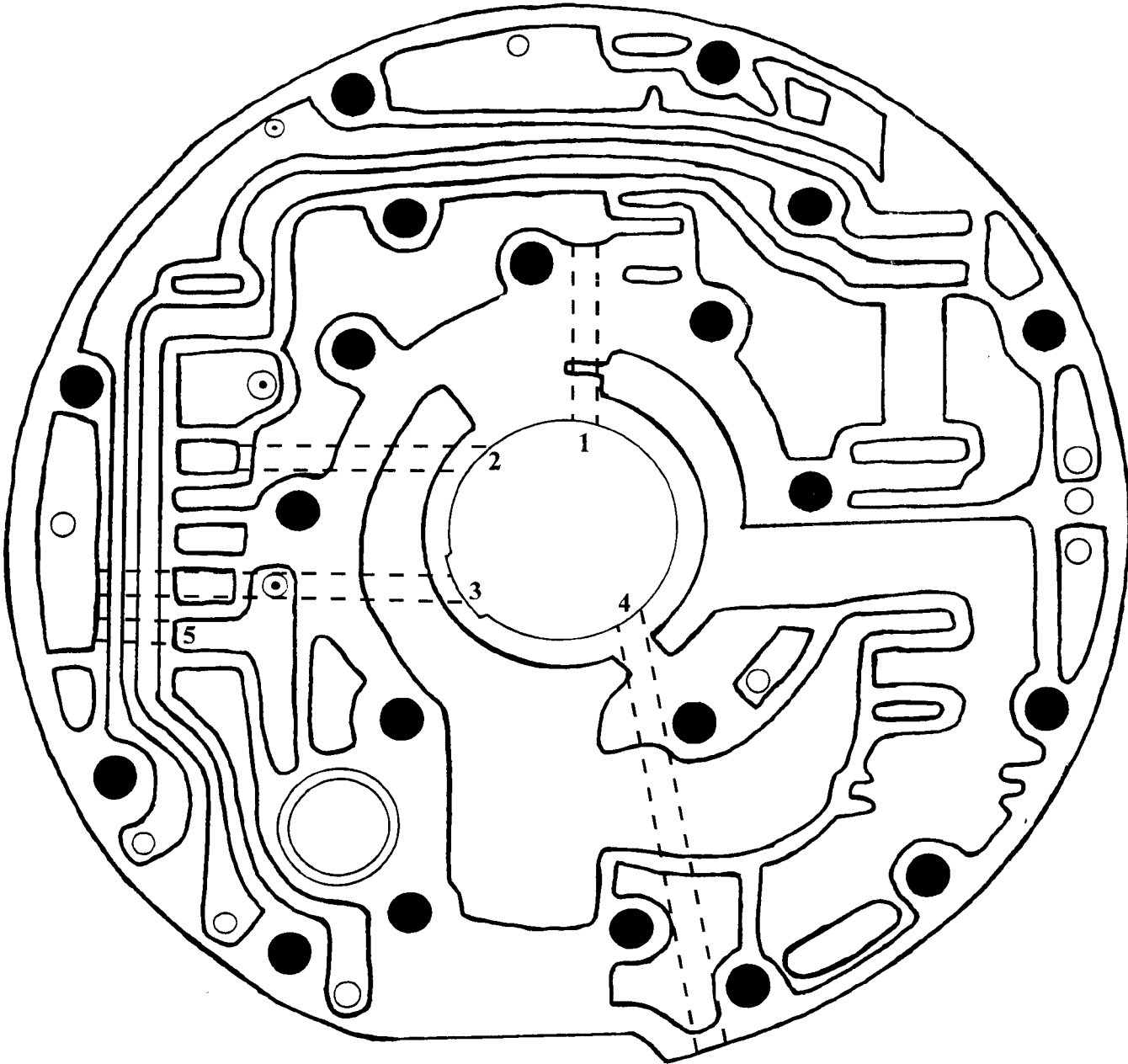
**E4OD PUMP COVER
OIL PASSAGE IDENTIFICATION**



- | | |
|---------------------------------|---------------------------------|
| 1. PUMP SUCTION | 10. PUMP SEAL DRAIN |
| 2. LINE PRESSURE | 11. VOID |
| 3. EPC BOOST | 12. EXHAUST |
| 4. MANUAL 1ST AND REVERSE BOOST | 13. CONVERTER RELEASE |
| 5. CONVERTER CLUTCH SIGNAL | 14. CONVERTER APPLY |
| 6. CONVERTER FEED | 15. RELEASE OIL EXHAUST |
| 7. TO COOLER | 16. TCC REGULATOR VALVE BALANCE |
| 8. VENT | 17. P.R. VALVE BALANCE |
| 9. REGULATED CONVERTER FEED | |

Figure 59

**E4OD PUMP COVER INTERNAL
PASSAGE IDENTIFICATION**



- 1. FRONT LUBE SUPPLY
- 2. CONVERTER RELEASE
- 3. CONVERTER APPLY
- 4. COAST CLUTCH FEED
- 5. TO COOLER

Figure 60



**FORD E4OD
NEW DESIGN INTERMEDIATE
SERVO PISTON ASSEMBLY**

CHANGE: Beginning on August 8, 1995, all 1996 model E4OD transmissions were produced with a new design Intermediate Band Apply Servo Assembly (See Figure 61).

REASON: Ease of installation on the assembly line.

PARTS AFFECTED:

- (1) INTERMEDIATE SERVO PISTON - Total change in design, as shown in Figure 61.
- (2) SERVO PISTON RETAINER - Eliminated, as shown in Figure 61.
- (3) RETAINING SNAP RING - Eliminated, as shown in Figure 61.
- (4) TRANSMISSION CASE - Snap ring groove in the case piston bore was eliminated, as it was no longer need (See Figure 62).

INTERCHANGEABILITY:

- (1) When replacing the Intermediate Band Apply Servo Assembly becomes necessary, either design level (Previous or New) can be used in a previous model transmission case, as the new design level part will retro-fit back to all previous model units.
- (2) When using the new design piston and seal assembly in a previous model transmission, discard the piston retainer and the snap ring.
- (3) If you have the later model transmission without the snap ring groove in the piston bore, *only* the new design piston and seal assembly can be used.

SERVICE INFORMATION:

Intermediate Servo Piston Assembly (New Design) F6TZ-7D021-A

FORD E4OD NEW DESIGN INTERMEDIATE SERVO PISTON ASSEMBLY

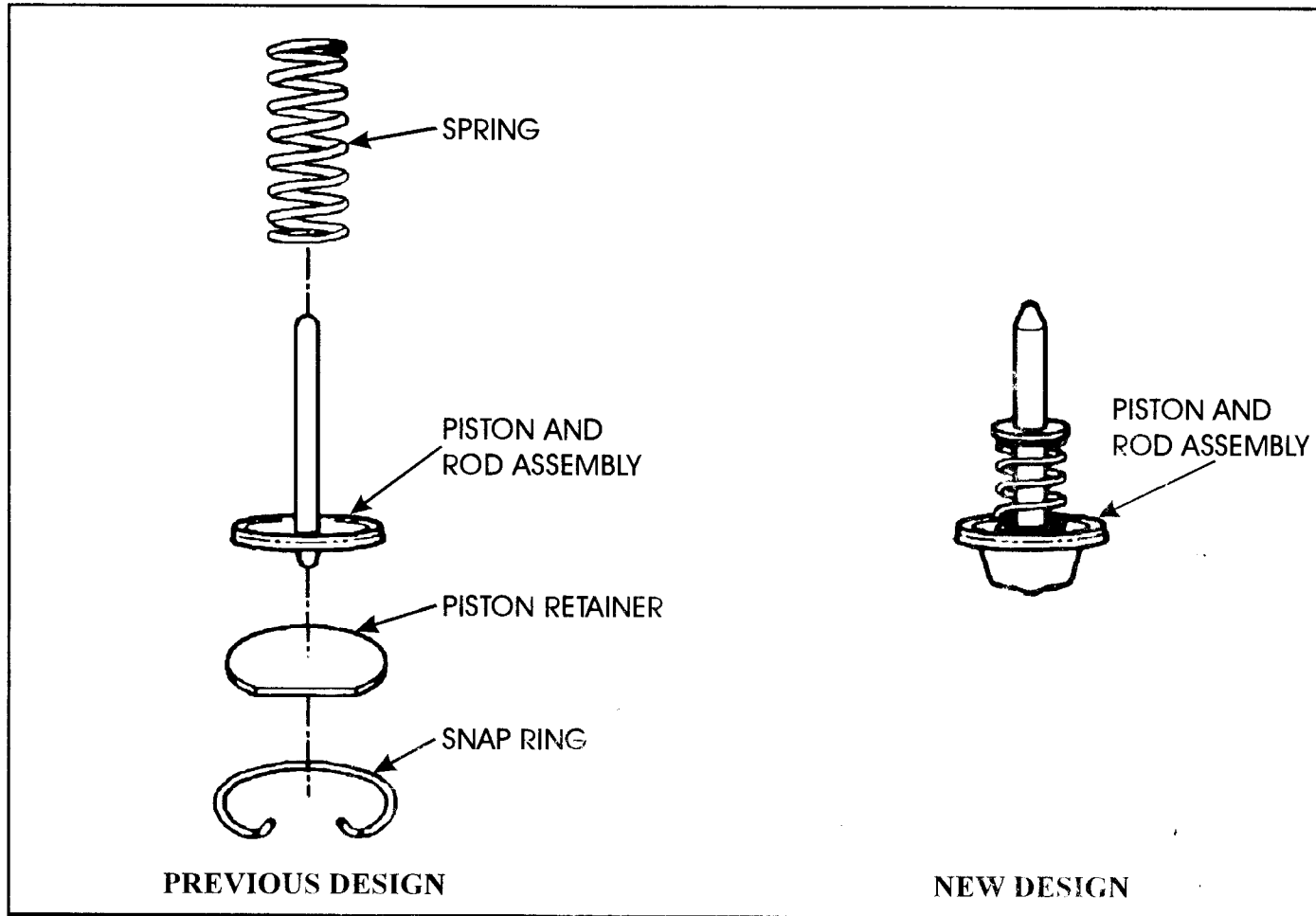


Figure 61

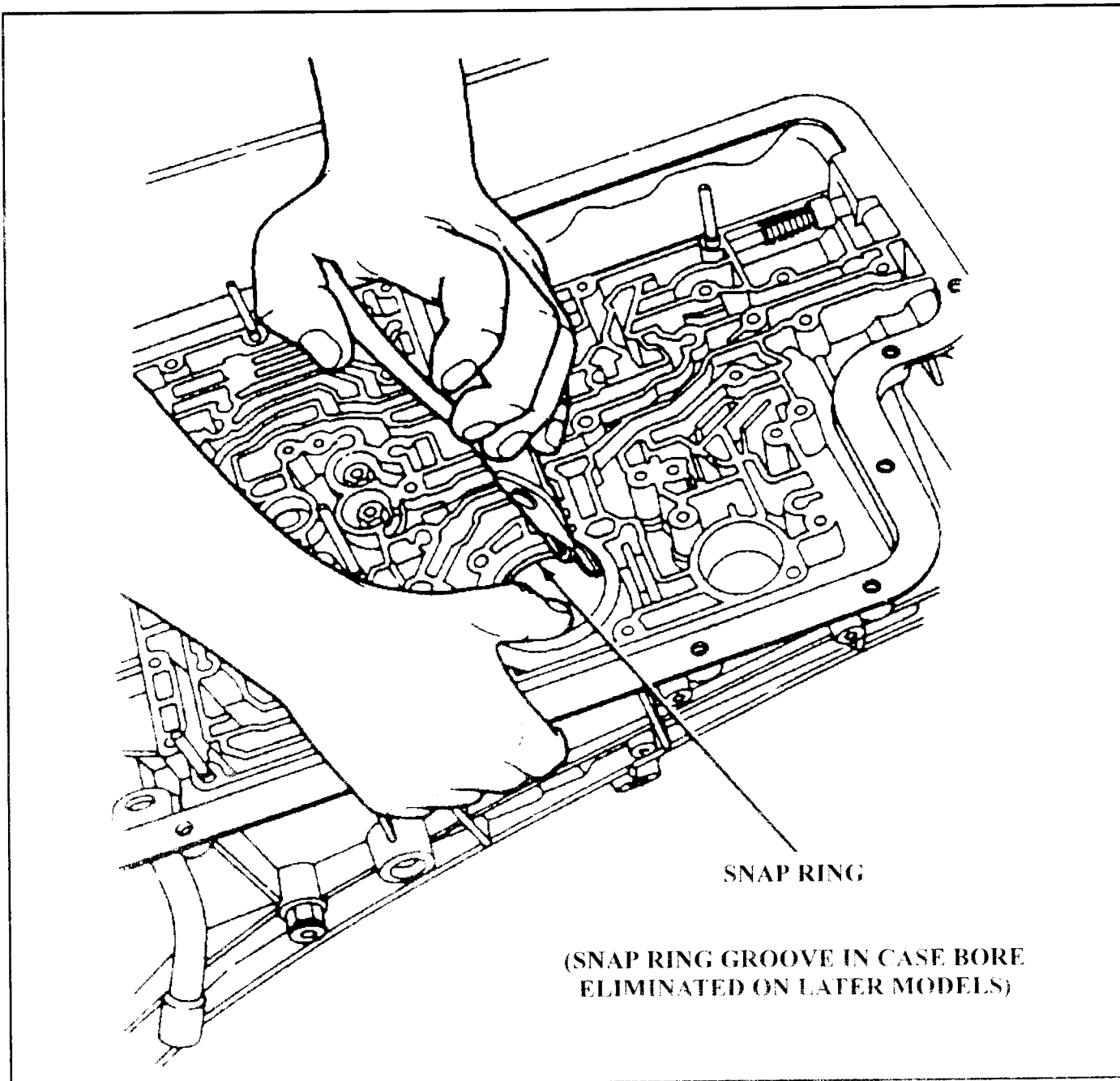


Figure 62



Technical Service Information

FORD E4OD FORWARD/REVERSE SUN GEAR

Some models of the E4OD transmission have been built with a Forward/Reverse Sun Gear that does not require a retaining snap ring, and has no groove for a snap ring, as shown in Figure 63. These transmissions are identified as model PRA-FA 12, serial number 00157935 thru 00158019. If internal transmission repair is required for these units, replace the Forward/Reverse Sun Gear with the current service sun gear with the snap ring groove, and the snap ring (See Figure 63).

***DO NOT REUSE THE FORWARD/REVERSE SUN GEAR
IF THE SUN GEAR HAS NO SNAP RING GROOVE.***

Forward/Reverse Sun Gear (With Groove) E9TZ-7D063-A
Retaining Snap Ring 377300-S

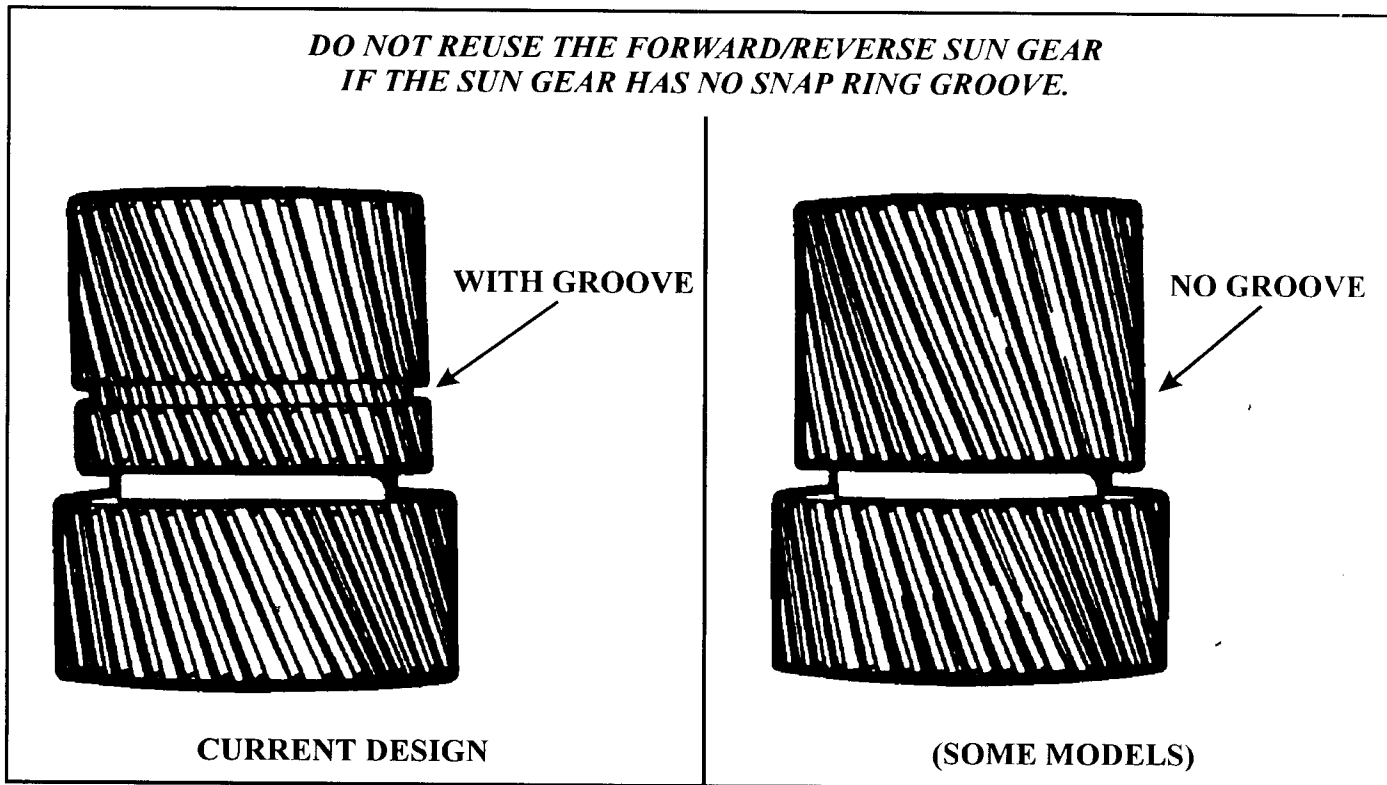


Figure 63

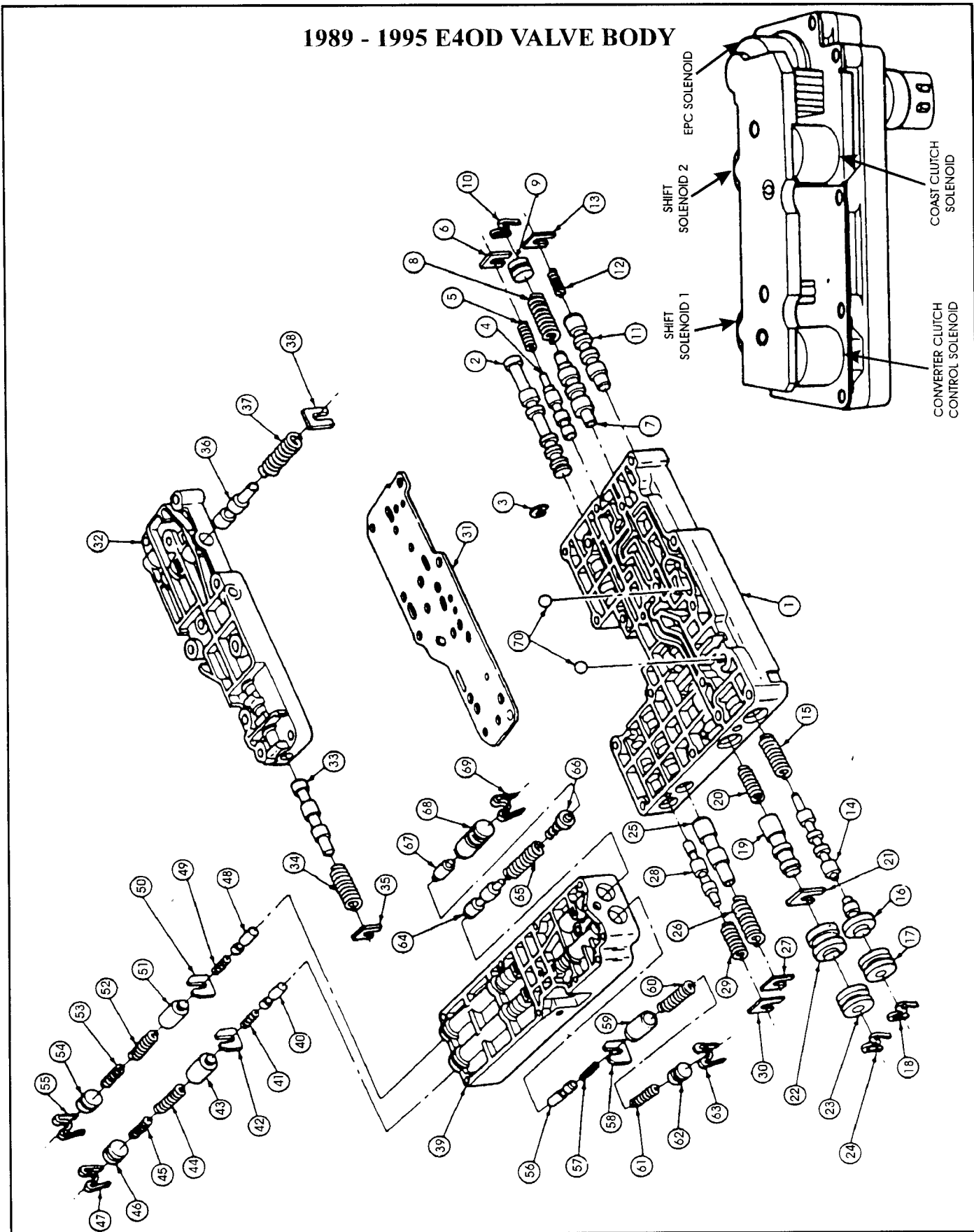


Figure 64

AUTOMATIC TRANSMISSION SERVICE GROUP



Technical Service Information

ITEM	DESCRIPTION	ITEM	DESCRIPTION
1	Main Control Body	36	1-2 Manual Transition
2	Manual Valve	37	Spring
3	Retainer	38	Retainer
4	Low/Rev Modulator Valve	39	Accumulator Body
5	Spring	40	OD Clutch Accumulator Regulator Valve
6	Retainer	41	Spring
7	3-4 Shift Valve	42	Retainer
8	Spring	43	OD Clutch Accumulator Plunger
9	Plug	44	Outer Spring
10	Clip	45	Inner Spring
11	2-3 Shift Valve	46	Plug
12	Spring	47	Clip
13	Retainer	48	Direct Clutch Accumulator Reg. Valve
14	D2 Shift Valve	49	Spring
15	Spring	50	Retainer
16	1-2 Shift Valve	51	Direct Clutch Accumulator Plunger
17	Plug	52	Outer Spring
18	Clip	53	Inner Spring
19	4-3-2 Manal Timing Valve	54	Plug
20	Spring	55	Clip
21	Retainer	56	Intermediate Clutch Accumulator Reg. Valve
22	4-3-2 Manual Timing Plunger	57	Spring
23	Plug	58	Retainer
24	Clip	59	Intermediate Clutch Accumulator Plunger
25	Coast Clutch Shift Valve	60	Outer Spring
26	Spring	61	Inner Spring
27	Retainer	62	Plug
28	Solenoid Regulator Valve	63	Clip
29	Spring	64	Line Pressure Modulator Valve
30	Retainer	65	Outer Spring
31	Separator Plate	66	Spring & Retainer Assembly
32	Lower Control Body	67	Line Pressure Modulator Plunger Valve
33	Engagement Control Valve	68	Line Pressure Modulator Sleeve
34	Spring	69	Clip
35	Retainer	70	Check Ball

Figure 64 Legend

1996 E4OD VALVE BODY

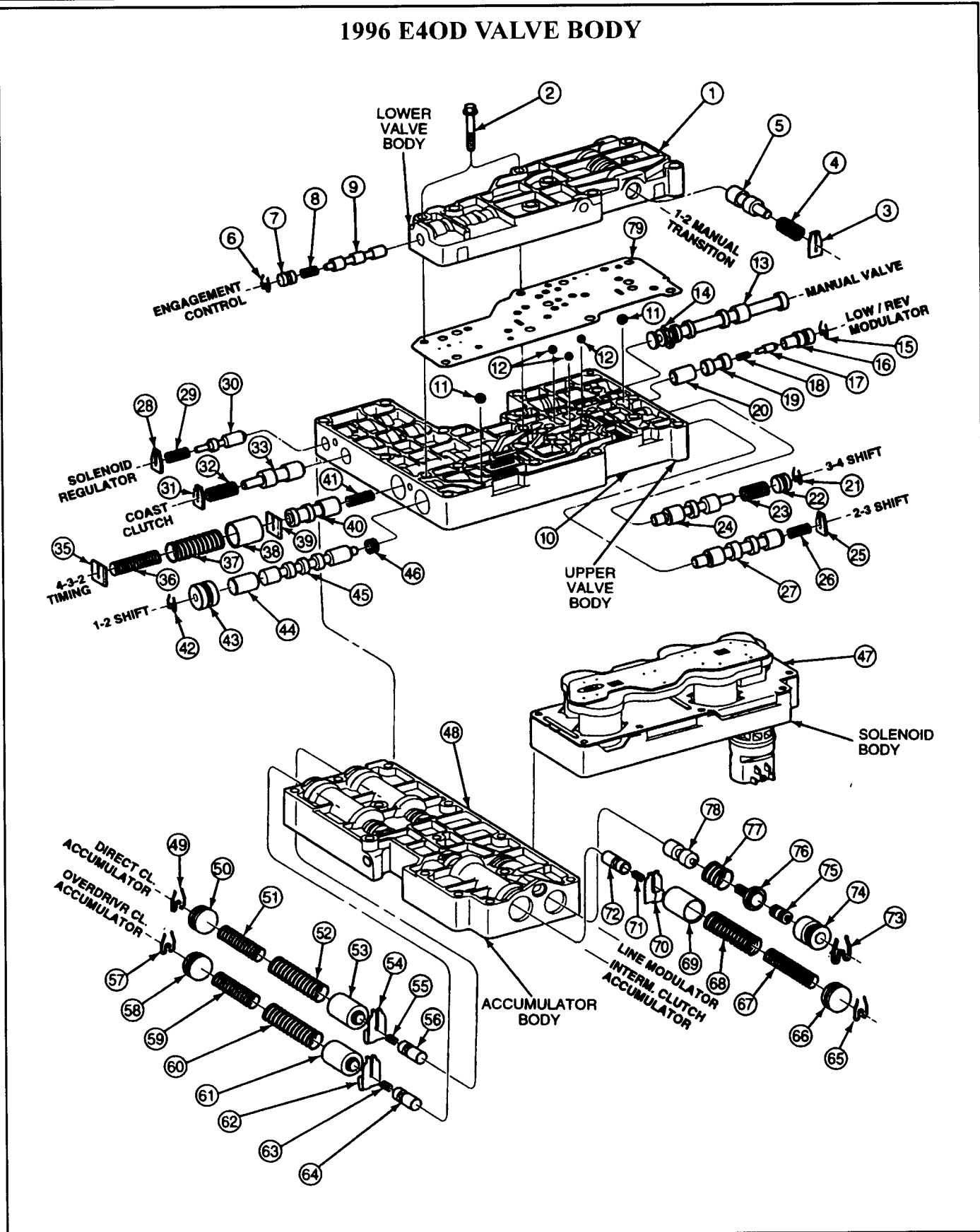


Figure 65



Technical Service Information

ITEM	DESCRIPTION	ITEM	DESCRIPTION
1	Body Control Valve - Lower	40	Valve, 4-3-2 Timing
2	Bolt M1 - 1x36 Hex Flange Head (2 Req'd)	41	Spring, 4-3-2 Shift Timing
3	Plate, Spring Retainer	42	Retainer, Valve Plug
4	Spring, Shift Valve	43	Plug, Valve Retainer
5	Valve, Coast Clutch Shift	44	Valve, 1-2 Shift
6	Retainer, Valve Plug	45	Valve, D-2
7	Plug, Valve Retainer	46	Spring, 1-2 Shift Valve
8	Spring, Engagement Valve	47	Solenoid Body Assembly
9	Valve, Control Engagement	48	Accumulator Valve Body Control
10	Body, Control Valve - Upper	49	Retainer, Main Pressure Boost
11	Ball, 5/16-Inch Shuttle	50	Plug, Valve Retainer
12	Ball, 1/4-Inch Shuttle	51	Spring Accumulator Inner
13	Valve, Control Manual	52	Spring Accumulator Outer
14	Ring, Retainer	53	Plunger, Accumulator Regulator
15	Retainer, Valve Plug	54	Retainer, Accumulator Spring
16	Sleeve, Low/Rev. Modulator Valve	55	Spring, Accumulator Regulator Valve
17	Plunger, Low/Rev. Modulator Valve	56	Valve, Accumulator Regulator
18	Spring, Low Servo Modulator	57	Retainer, Main Pressure Boost
19	Valve, Low Servo Modulator	58	Plug, Valve Retainer
20	Valve, Low/Rev. Modulator	59	Spring Accumulator Inner
21	Retainer, Valve Plug	60	Spring Accumulator Outer
22	Plug, Valve Retainer	61	Plunger, Accumulator Regulator
23	Spring, Shift Valve	62	Retainer, Accumulator Spring
24	Valve, 3-4 Shift	63	Spring, Accumulator Regulator Valve
25	Plate, Spring Retainer	64	Valve, Accumulator Regulator
26	Spring, 2-3 Shift Valve	65	Retainer, Main Pressure Boost
27	Valve, 2-3 Shift	66	Plug, Valve Retainer
28	Plate, Spring Retainer	67	Spring Accumulator Inner
29	Spring Solenoid Regulator Valve	68	Spring Accumulator Outer
30	Solenoid, Regulator Valve	69	Plunger, Accumulator Regulator
31	Plate, Spring Retainer	70	Retainer, Accumulator Spring
32	Spring, Shift Valve	72	Valve, Accumulator Regulator
33	Valve, Coast Clutch Shift	73	Retainer, Main Pressure Boost
35	Plate, Spring Retainer	74	Sleeve, Line Pressure Modulator
36	Spring, 4-3-2 Shift Timing	75	Plunger, Line Pressure Modulator
37	Spring, 4-3-2 Shift Timing	76	Spring & Retainer Assembly, Pressure Modulator
38	Plunger, Control Valve Shift Timing		
39	Plate, Spring Retainer		

Figure 65 Legend

AUTOMATIC TRANSMISSION SERVICE GROUP



FORD E4OD NO FLOW TO COOLER, AFTER REBUILD

COMPLAINT: After rebuild, your E4OD transmission is returned with premature planetary failure due to a lack of lubrication, *or* if you checked lube flow before delivery, you find zero lube flow, and zero flow from the front "To Cooler" fitting.

CAUSE: The cause may be, mis-match of stator shaft and pump cover creating a *totally blocked* "To Cooler" passage in the pump cover.

CORRECTION: Install the proper stator shaft into the proper pump cover. The differences are as follows:

- (1) **89-94 MODELS** - Have a relief (Notch) cut into the *pump cover* on the inside diameter, where the stator shaft presses into the cover, creating a passage for converter apply oil to get into the "To Cooler" passage in the pump cover. Refer to Figure 67.
- (2) **95-96 MODELS** - The relief (Notch) cut in the pump cover was eliminated from the cover, and the relief (Notch) cut was added to the *stator shaft* (See Figure 67).
- (3) If for any reason, it becomes necessary to install a different stator shaft into your pump cover, you *must* ensure that you are installing compatible parts.

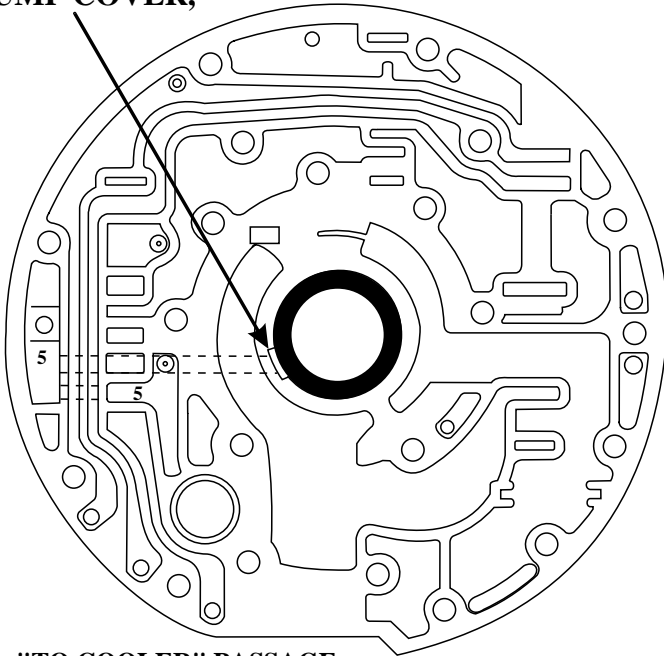
89-94 Model pump cover *with notch*, **MUST** be used with the stator shaft *without notch*. Refer to Figure 67.

95-96 Model pump cover *without notch*, **MUST** be used with the stator shaft *with notch*. Refer to Figure 67.

If you install a 89-94 stator shaft *without notch*, into a 95-96 pump cover *without notch* -- You will create a *totally blocked "To Cooler" passage* in the pump cover. Refer to Figure 67.

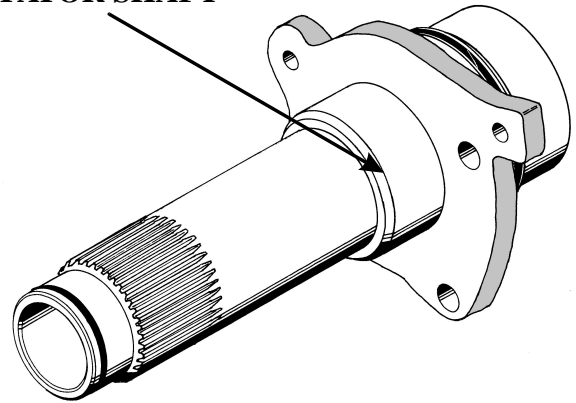
"CORRECT" ASSEMBLY
89-94 PUMP STATOR (WITHOUT NOTCH)
IN 89-94 PUMP COVER (WITH NOTCH)

NOTCH IN
PUMP COVER,



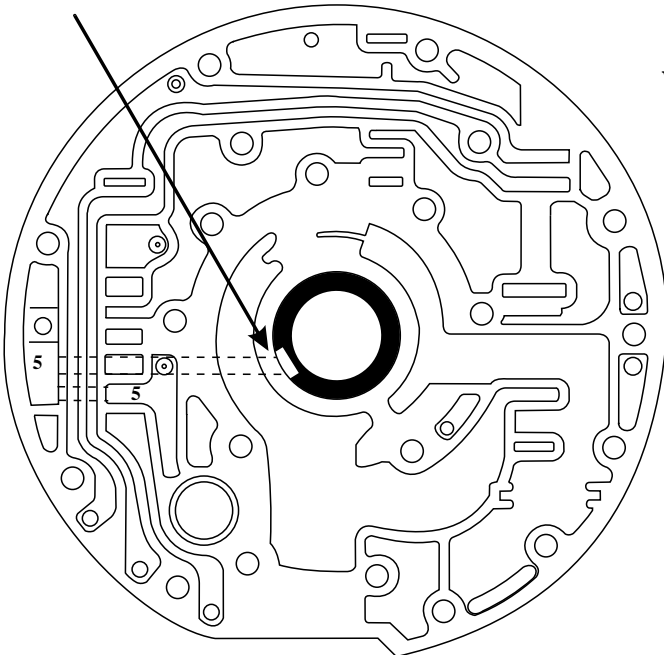
5. "TO COOLER" PASSAGE

NO NOTCH IN
STATOR SHAFT



"CORRECT" ASSEMBLY
95-96 PUMP STATOR (WITH NOTCH)
IN 95-96 PUMP COVER (WITHOUT NOTCH)

NO NOTCH IN
PUMP COVER,



5. "TO COOLER" PASSAGE

WITH NOTCH IN
STATOR SHAFT

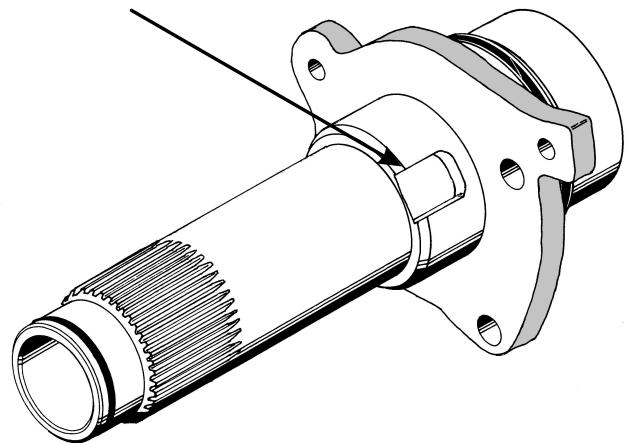


Figure 67
AUTOMATIC TRANSMISSION SERVICE GROUP



**FORD E4OD
REVERSE CLUTCH LIP SEALS
FOR 1996 MODELS**

CHANGE: Beginning at the Start Of Production for all 1996 models equipped with the E4OD transmission, Ford Motor Company installed "Lip" seals on the reverse clutch piston and added a cushion (Wave) plate to the reverse clutch pack.

REASON: To address reverse engagement concerns.

PARTS AFFECTED:

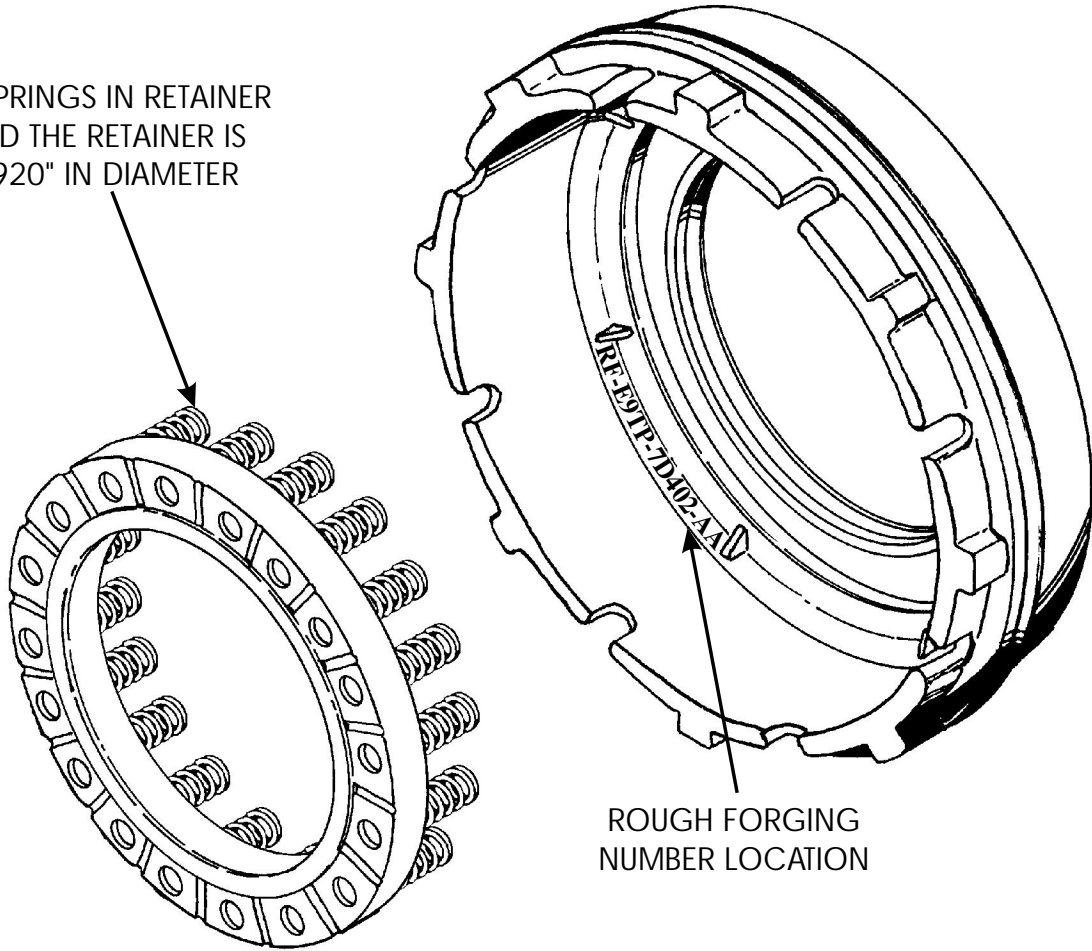
- (1) REVERSE CLUTCH PISTON SEALS - Change from the previous "Square" cut seals to the new design "Lip" seals, for increased sealing ability. Refer to Figures 68, 69 and 70.
- (2) REVERSE PISTON - Seal grooves in the piston are machined differently to accommodate the new design lip seals. The reverse piston skirt is also .140" shorter than the previous piston, to accommodate the added cushion (Wave) plate in the reverse clutch pack. This will obviously also affect the overall height of the piston. Refer to Figures 68, 69 and 70.
The pistons can be identified by the "Rough Forging" number, as shown in Figures 68 and 69.
Rough Forging Number RF-E9TP-7D402-AA = 89-95 Model (Square Cut Seals)
Rough Forging Number RF-F6TP-7D402-AA = 1996 Model (Lip Seals)
- (3) REVERSE PISTON SPRING RETAINER - New design level spring retainer has 23 return springs in the retainer, instead of the previous 18 return springs. The new design level 23 spring retainer is also approximately 1/4" larger in diameter, 5.200" as opposed to the previous 4.920", which will allow a better cushion. Refer to Figures 68 and 69.
- (4) CUSHION (WAVE) PLATE - Added to the reverse clutch pack to cushion the reverse clutch apply, as shown in Figure 70. The new cushion plate when it is not compressed, is .140" in height and the nominal thickness is .080".

SERVICE INFORMATION:

Reverse Clutch Piston (New Design)	F6TZ-7D402-A
Reverse Piston Outer Lip Seal (Package of 3)	F6TZ-7D403-A
Reverse Piston Inner Lip Seal (Package of 3)	F6TZ-7D404-A
Reverse Piston Return Spring Assembly (New Design)	F6TZ-7D406-A
Reverse Clutch Cushion Spring	F6TZ-7D085-A

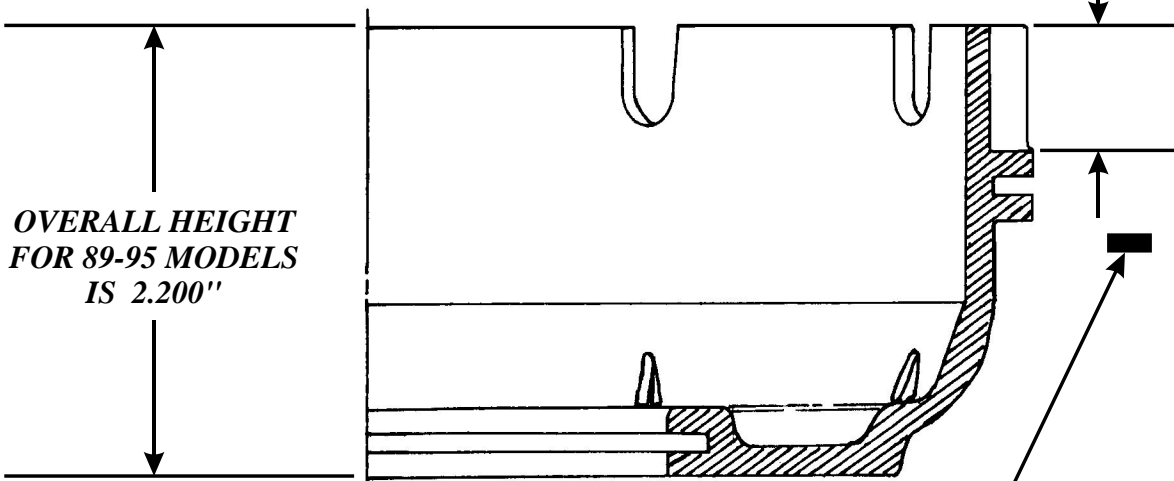
1989-1995 MODEL REVERSE CLUTCH PISTON AND SPRING RETAINER

18 SPRINGS IN RETAINER
AND THE RETAINER IS
4.920" IN DIAMETER



ROUGH FORGING
NUMBER LOCATION

*SKIRT HEIGHT
IS APPROX .640"*



*OVERALL HEIGHT
FOR 89-95 MODELS
IS 2.200"*

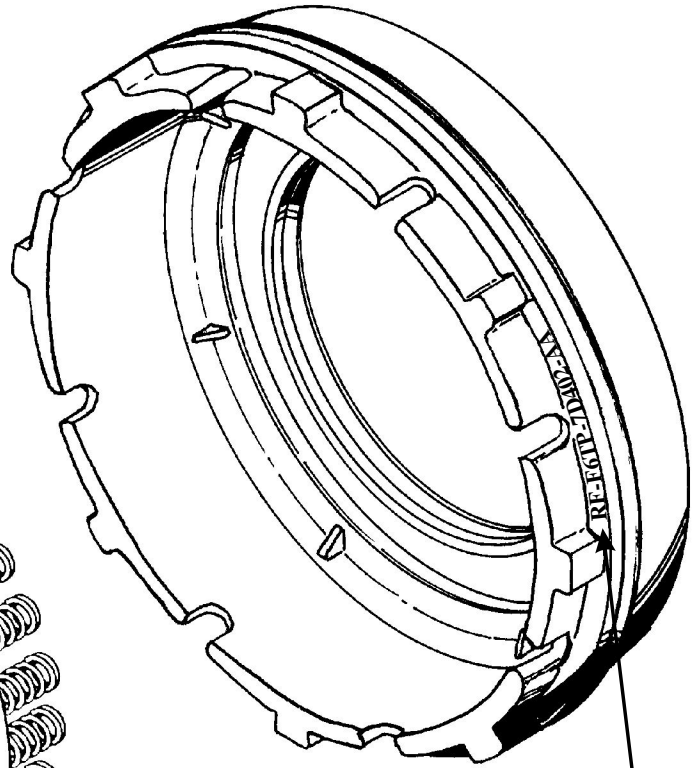
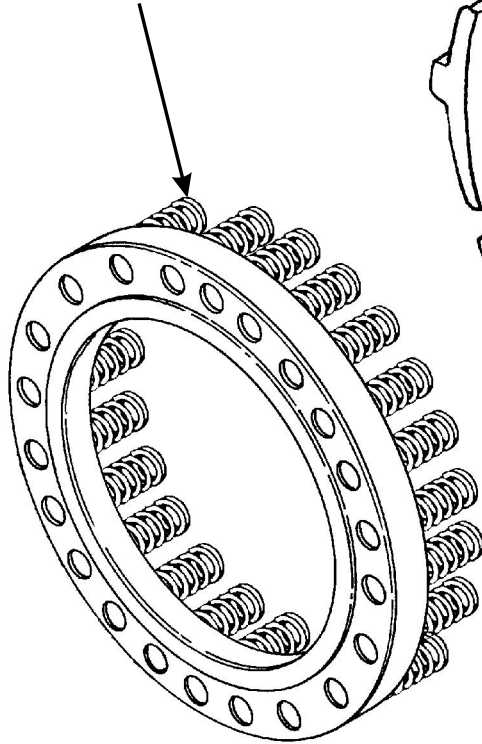
PREVIOUS DESIGN
SQUARE CUT SEALS

Copyright © 2004 ATSG

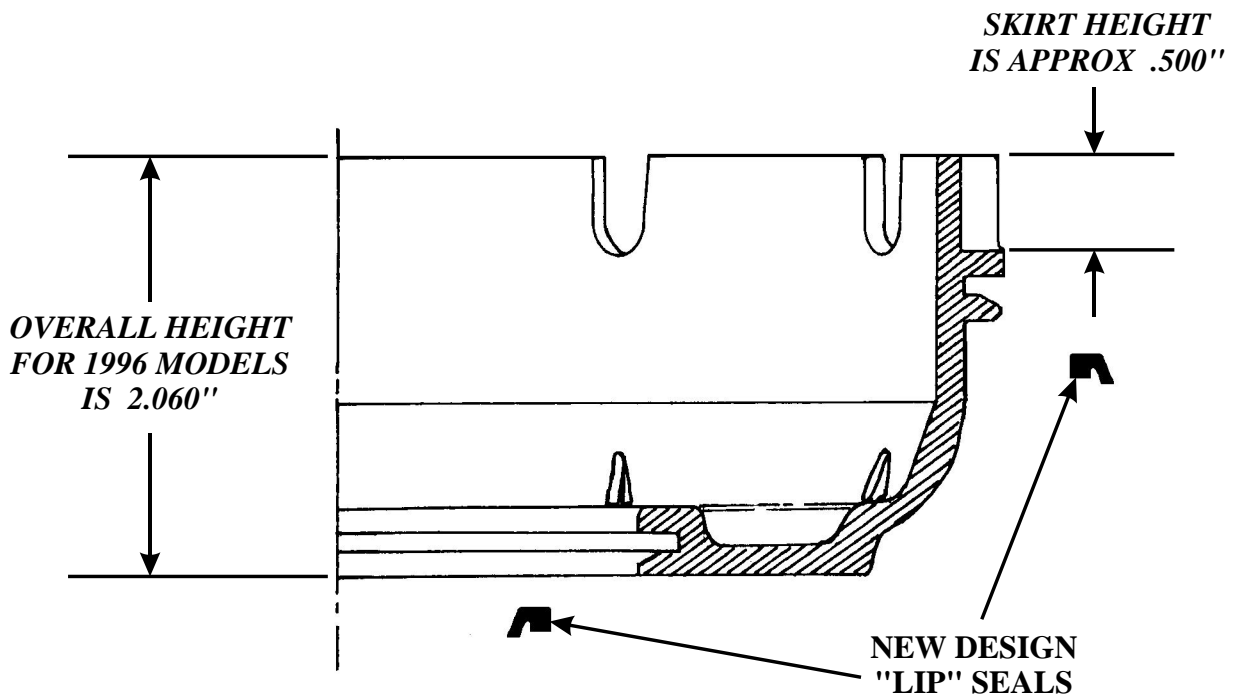
Figure 68

1996 MODEL REVERSE CLUTCH PISTON AND SPRING RETAINER

23 SPRINGS IN RETAINER
AND THE RETAINER IS
5.200" IN DIAMETER



ROUGH FORGING
NUMBER LOCATION



Copyright © 2004 ATSG

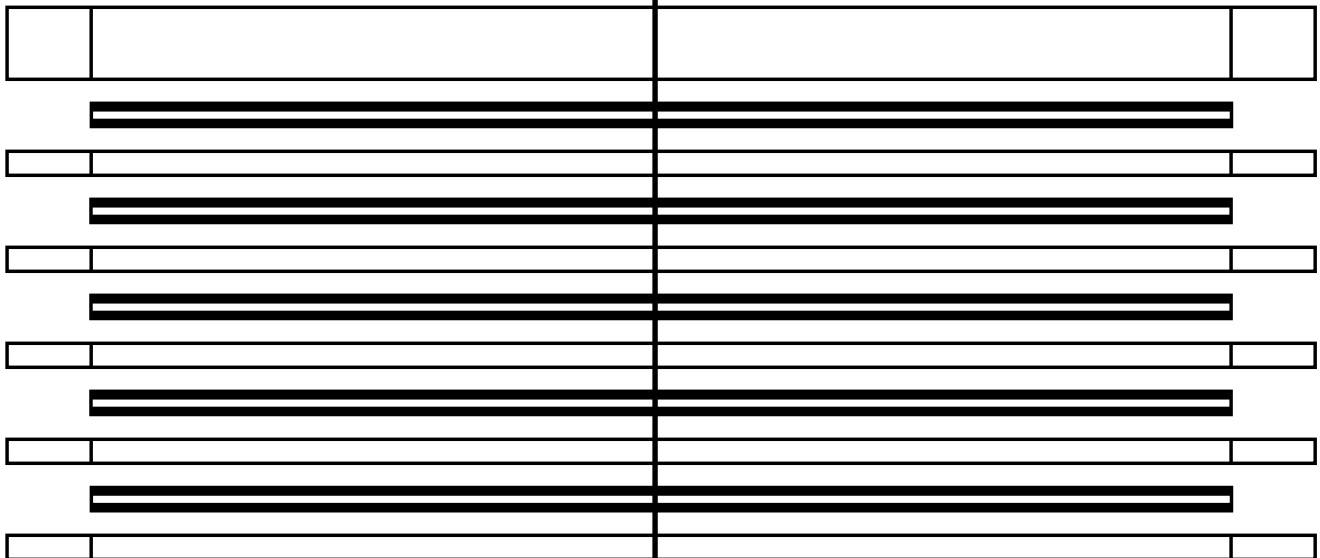
Figure 69

**89-95 MODEL
REVERSE CLUTCH STACK**

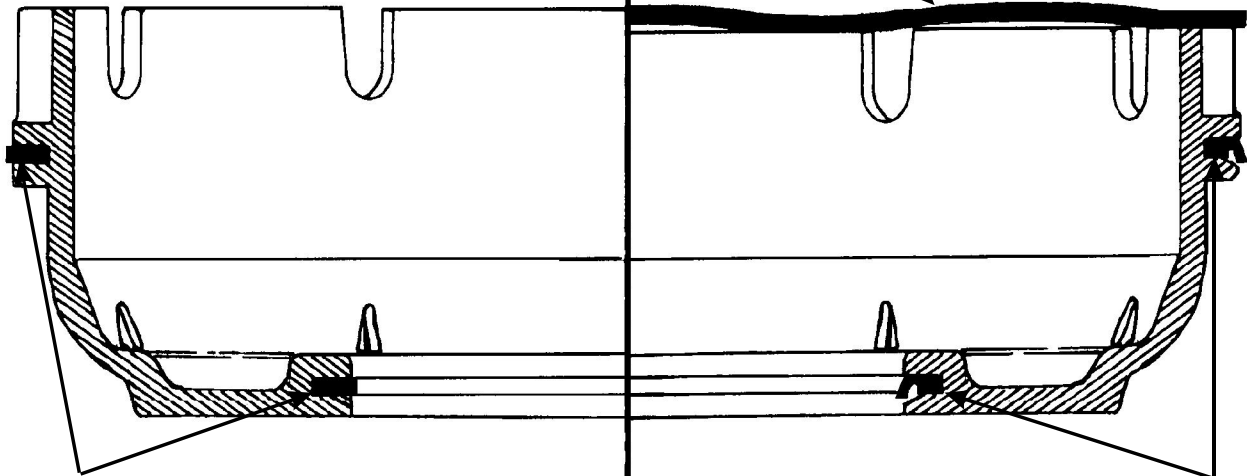
NOTE: THE NUMBER OF REVERSE CLUTCH PLATES FOR THE REVERSE CLUTCH IS MODEL DEPENDENT

**1996-UP MODEL
REVERSE CLUTCH STACK**

NOTE: THE NUMBER OF REVERSE CLUTCH PLATES FOR THE REVERSE CLUTCH IS MODEL DEPENDENT



ADDED WAVE PLATE



PREVIOUS DESIGN
LATHE CUT SEALS

NEW DESIGN
LIP SEALS
Copyright © 2004 ATSG

Figure 70



FORD E4OD
LARGER DESIGN LOW ROLLER CLUTCH
FOR 1997 MODELS

CHANGE: Beginning at the start of production for 1997 models, some models of the E4OD transmission were built with a new design low roller clutch that is larger, and a new design reverse clutch assembly.

REASON: Much improved durability and reliability.

PARTS AFFECTED:

- (1) LOW ROLLER CLUTCH ASSEMBLY - New design is larger in diameter, has 17 rollers instead of the previous 16 rollers, and the plastic is "Tan" in color instead of black for easy identification. Refer to Figure 71.
(2) LOW ROLLER CLUTCH INNER RACE - New design is 3.385" in diameter instead of the previous 3.189" diameter, to accommodate the new low roller clutch. There is no other means of identification on the inner race other than measuring the diameter. Refer to Figure 71.
(3) REVERSE CLUTCH HUB - New design has a larger diameter "Cam" installed into the rear of reverse clutch hub to accommodate the larger low roller clutch, and the shell is now stamped, and has wider grooves for the reverse clutch teeth. Refer to Figure 72.
(4) REVERSE CLUTCH FRICTION PLATES - New design friction plates are manufactured with wider teeth to fit the new design reverse clutch hub. Refer to Figure 72.
(5) REAR PLANETARY CARRIER - New design level has narrow teeth on the outside diameter instead of the previous wide teeth, to accommodate the new design reverse clutch hub. Refer to Figures 73 and 74.

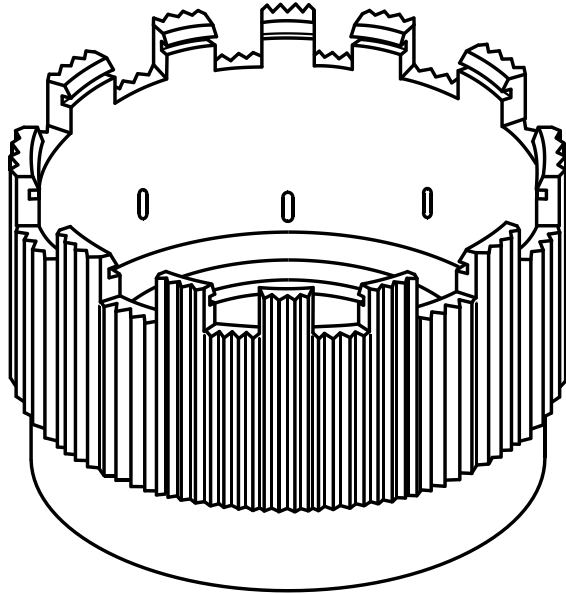
INTERCHANGEABILITY:

The new design parts will retro-fit back to all previous models, as long as all parts listed above are used as a package. The low roller clutch assembly must be installed into the back side of the reverse clutch hub regardless of which design level you are using, as shown in Figure 75.

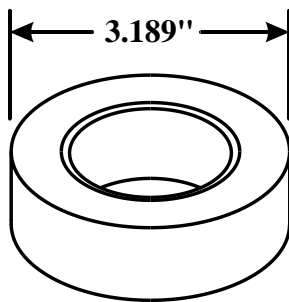
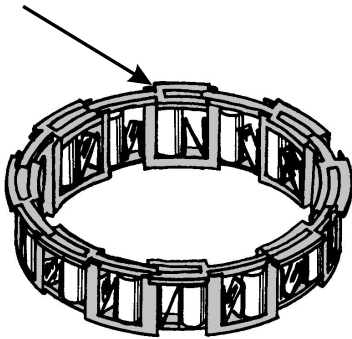
SERVICE INFORMATION:

Table with 3 columns: Part Name, Previous Design, New Design. Rows include Reverse Clutch Hub Assembly, Low Roller Clutch Assembly, Low Roller Clutch Inner Race, Reverse Planetary Carrier (4 Pinion), and Reverse Clutch Friction Plates.

**1989-1996 DESIGN LEVEL
REVERSE CLUTCH HUB,
LOW ROLLER CLUTCH,
AND INNER RACE**

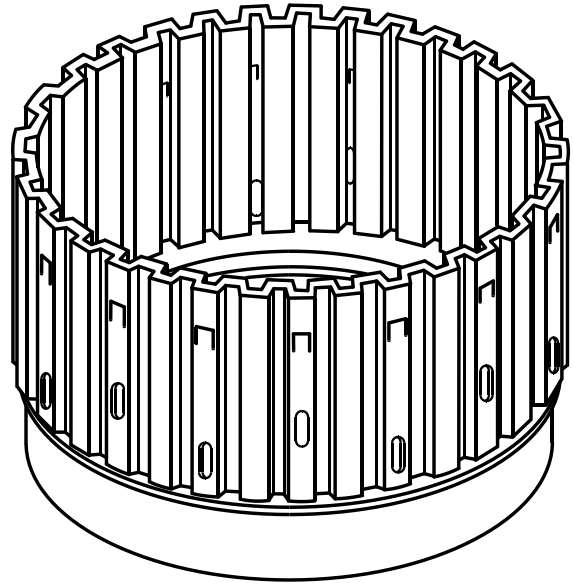


**"BLACK" PLASTIC CAGE
16 ROLLERS**

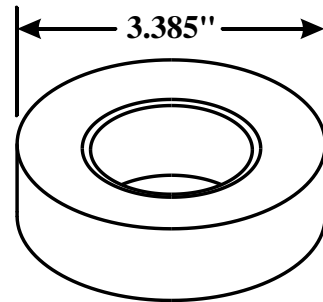
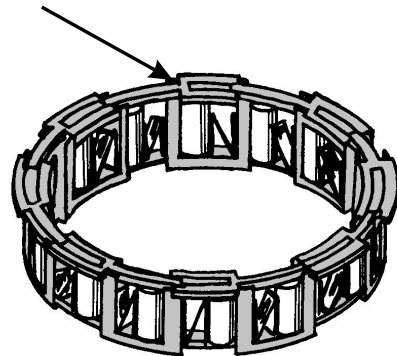


**LOW ROLLER
INNER RACE**

**1997-UP DESIGN LEVEL
REVERSE CLUTCH HUB,
LOW ROLLER CLUTCH,
AND INNER RACE**



**"TAN" PLASTIC CAGE
17 ROLLERS**

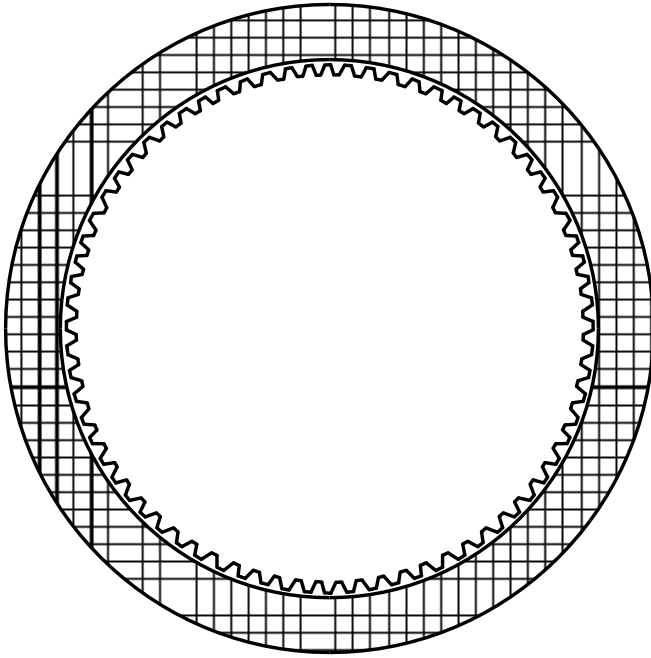


**LOW ROLLER
INNER RACE**

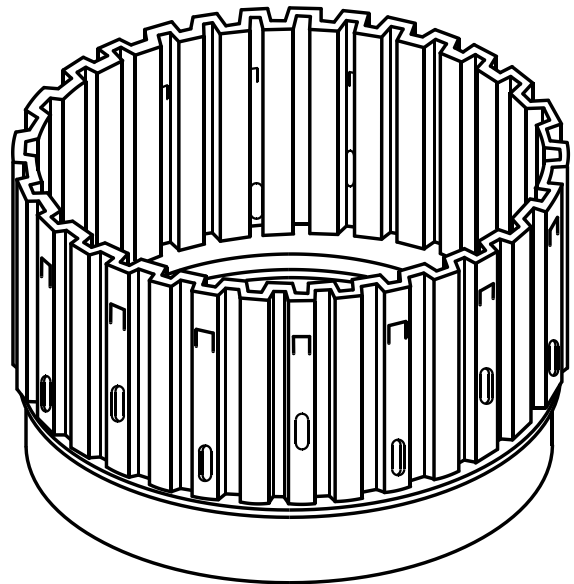
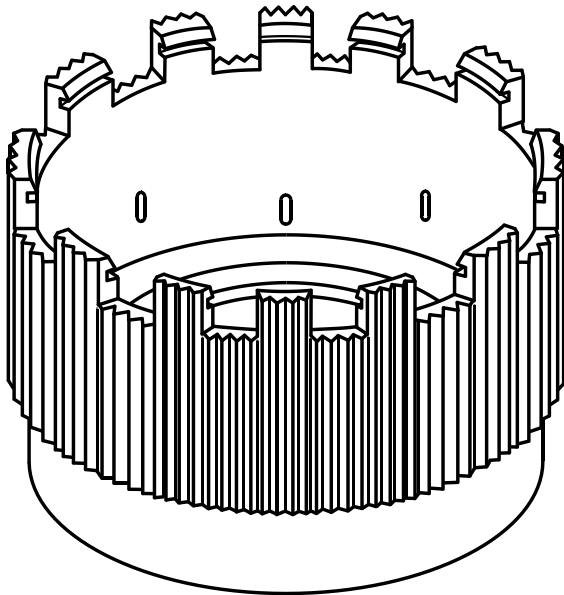
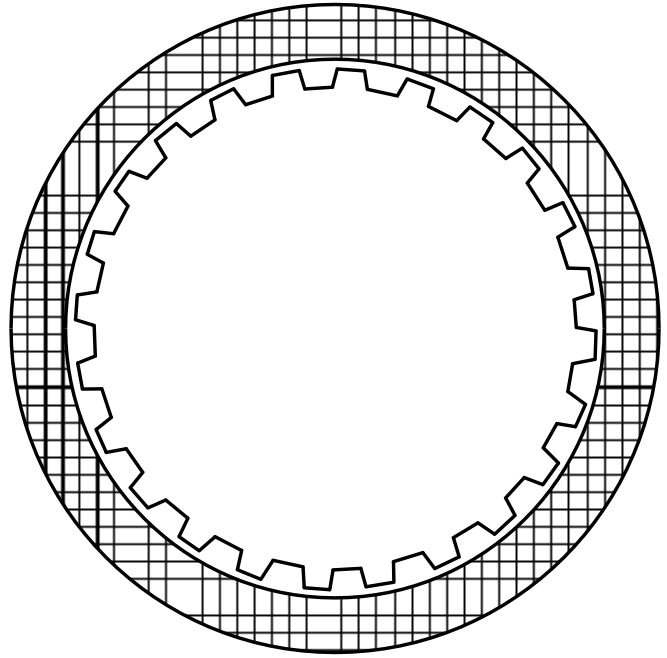
Copyright © 2004 ATSG

Figure 71

**1989-1996 DESIGN LEVEL
LOW/REVERSE CLUTCH PLATE
AND REVERSE CLUTCH HUB**



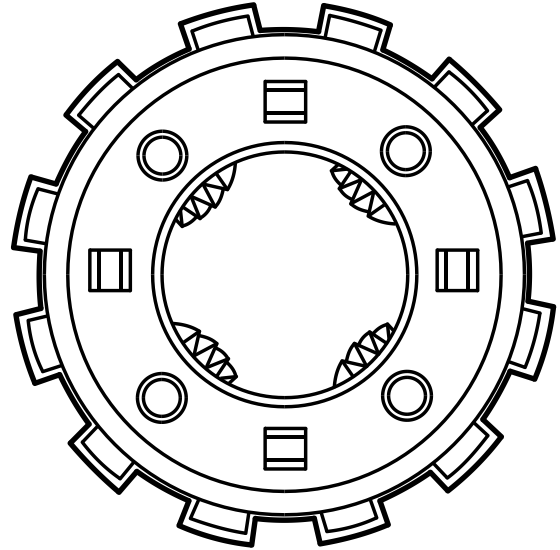
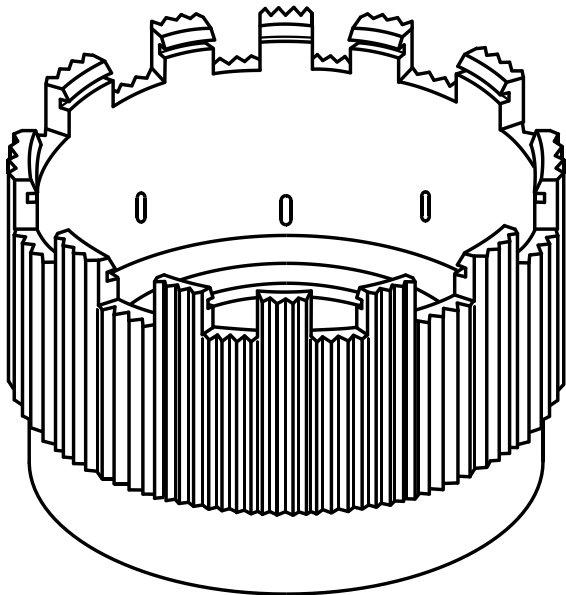
**1997-UP DESIGN LEVEL
LOW/REVERSE CLUTCH PLATE
AND REVERSE CLUTCH HUB**



Copyright © 2004 ATSG

Figure 72

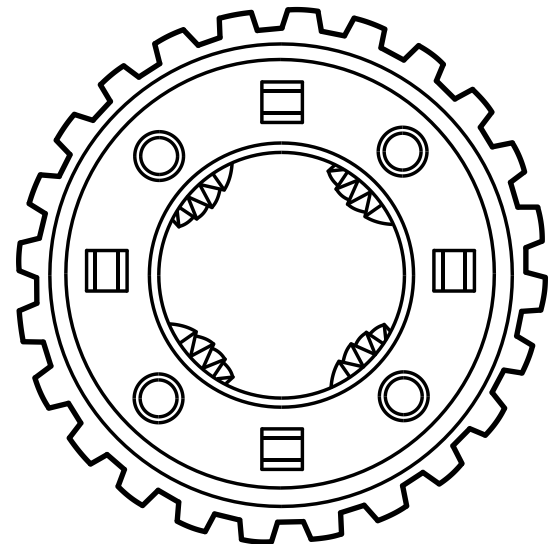
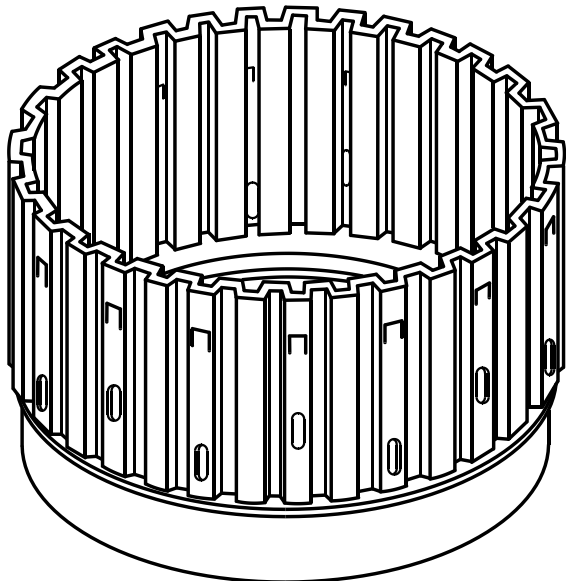
**1989-1996 DESIGN LEVEL
REVERSE CLUTCH HUB AND REAR PLANET ASSEMBLY**



Copyright © 2004 ATSG

Figure 73

**1997-UP DESIGN LEVEL
REVERSE CLUTCH HUB AND REAR PLANET ASSEMBLY**



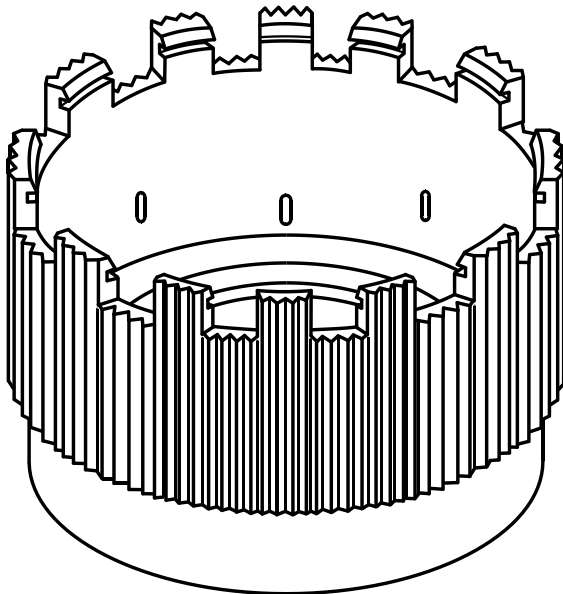
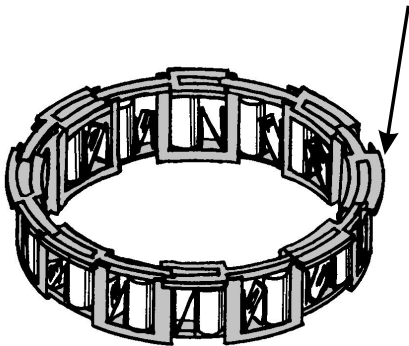
Copyright © 2004 ATSG

Figure 74

E4OD PLASTIC LOW ROLLER CLUTCH ASSEMBLY

***"INCORRECTLY"
INSTALLED***

***NOTE TABS ON
TOP OUTER EDGE***

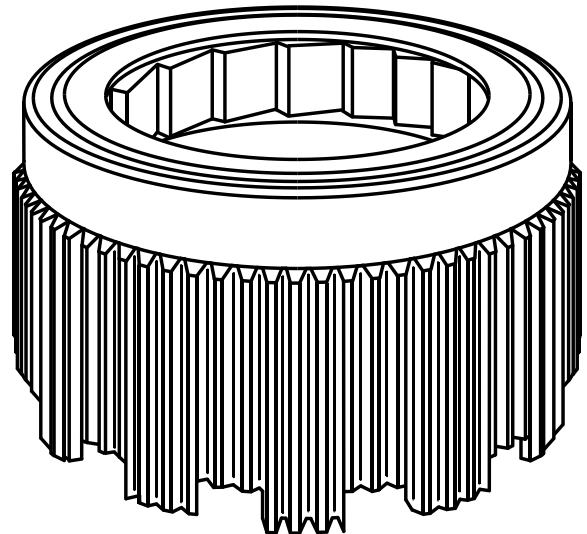
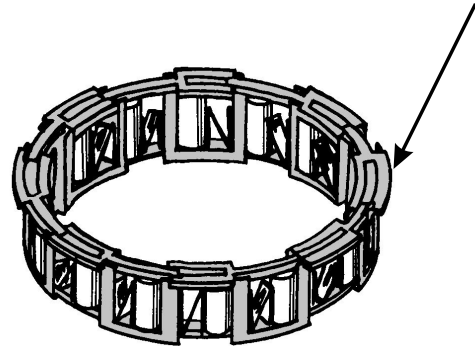


CAUTION

IF THE ROLLER CLUTCH IS INSTALLED IN THIS DIRECTION, THE REVERSE HUB WILL FREEWHEEL IN BOTH DIRECTIONS.

***"CORRECT"
INSTALLATION***

***NOTE TABS ON
TOP OUTER EDGE***



DISCARD BOTH SNAP RINGS. THEY ARE NOT USED WITH THE PLASTIC ROLLER CLUTCH

Copyright © 2004 ATSG

Figure 75



**FORD E40D
NEW DESIGN FORWARD RING GEAR HUB,
AND FORWARD PLANETARY, FOR 1997**

CHANGE: Beginning at the start of production for the 1997 model year, Ford Motor Company introduced a new design Forward Clutch Ring Gear Hub, to accommodate a new thrust bearing, that replaces the thrust washer on the forward planetary carrier, and a new design Forward Planetary Carrier that eliminates the thrust washer tab slots (See Figures 76 and 77).

REASON: Improved durability of the Front Planetary Carrier.

PARTS AFFECTED:

- (1) RING GEAR HUB - Now cut deeper on the side that goes against the forward planetary carrier by .100", to accommodate the new design bearing that replaced the thrust washer. Refer to Figure 76.
- (2) THRUST BEARING - Replaces the previous four tang thrust washer for improved durability. Refer to Figure 76.
- (3) FORWARD PLANETARY - Thrust washer slots have been eliminated, as shown in Figure 77, and there is an updated part number from Ford Motor Company, that is shown in Service Information below.

INTERCHANGEABILITY:

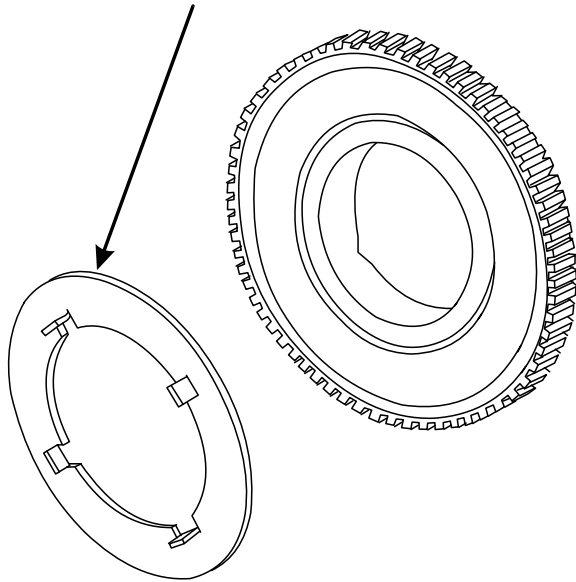
- (1) New design Ring Gear Hub *will* retro-fit back on all previous models, but you *must* use the new thrust bearing with it as a package. The old part number for the Ring Gear Hub will automatically supercede to the new Service Package part number, which includes both parts needed to retro-fit back on previous models. *Previous design is no longer available.*
- (2) New design Thrust Bearing must be used only with the new design Ring Gear Hub. It cannot be used on any previous models (See Figure 76).
- (3) There is also a new part number for the Forward Planetary Carrier, with no dimensional changes, and will retro-fit back on all previous models, but, *some* of the new part number carriers will not be cut to accept the four tang thrust washer. In that case you will have to install the new thrust bearing, which means you will also have to replace the ring gear hub with the new design level (See Figure 77).

SERVICE INFORMATION:

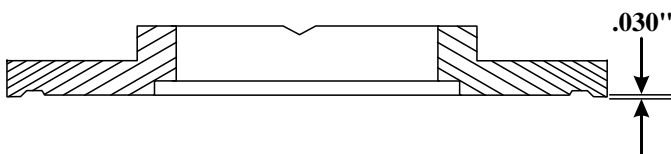
Forward Clutch Ring Gear Hub (New Design)	
(Includes New Design Thrust Bearing)	F7TZ-7B067-AB
Thrust Bearing Only (New Design)	F81Z-7A166-AA
Forward Planetary Carrier (New Part Number)	F7TZ-7A398-BA

EARLY FORWARD CLUTCH RING GEAR HUB

1989-1996 THRUST WASHER
PART NUMBER E9TZ-7A166-A
(No Longer Available From Ford)



1989-1996 RING GEAR HUB
.030" FROM WASHER SURFACE TO EDGE AS SHOWN,
AND REQUIRES THRUST WASHER SHOWN ABOVE.
(NO LONGER AVAILABLE FROM FORD)

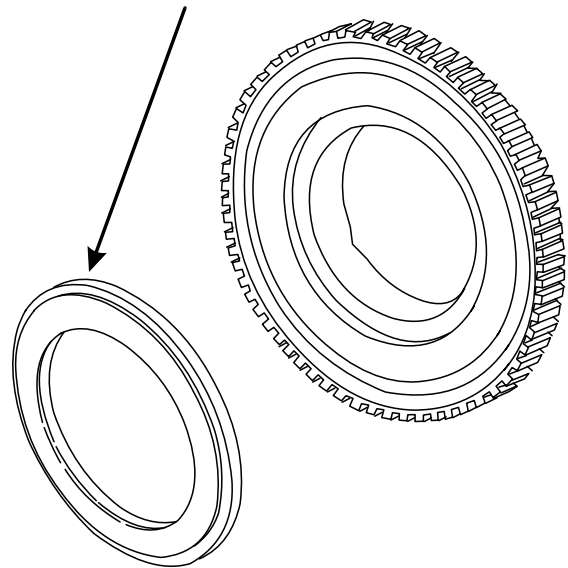


Special Note:

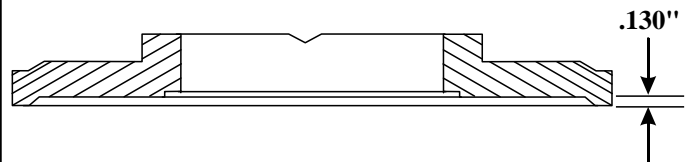
When ordering the Forward Clutch Ring Gear Hub from Ford Motor Co, it will automatically supercede to the newest Service Package part number F7TZ-7B067-AB, and will come with the new design thrust bearing. When used together these parts will retro-fit back to 1989.

LATE FORWARD CLUTCH RING GEAR HUB

1997-UP THRUST BEARING
PART NUMBER F81Z-7A166-AA
(Now Available From Ford)



1997-UP RING GEAR HUB
.130" FROM WASHER SURFACE TO EDGE AS SHOWN,
AND REQUIRES THRUST BEARING SHOWN ABOVE.
RING GEAR HUB PART NUMBER F7TZ-7B067-AB.



Special Note:

When ordering the Forward Clutch Ring Gear Hub from Ford Motor Co, it will automatically supercede to the newest Service Package part number F7TZ-7B067-AB, and will come with the new design thrust bearing. When used together these parts will retro-fit back to 1989.

Figure 76

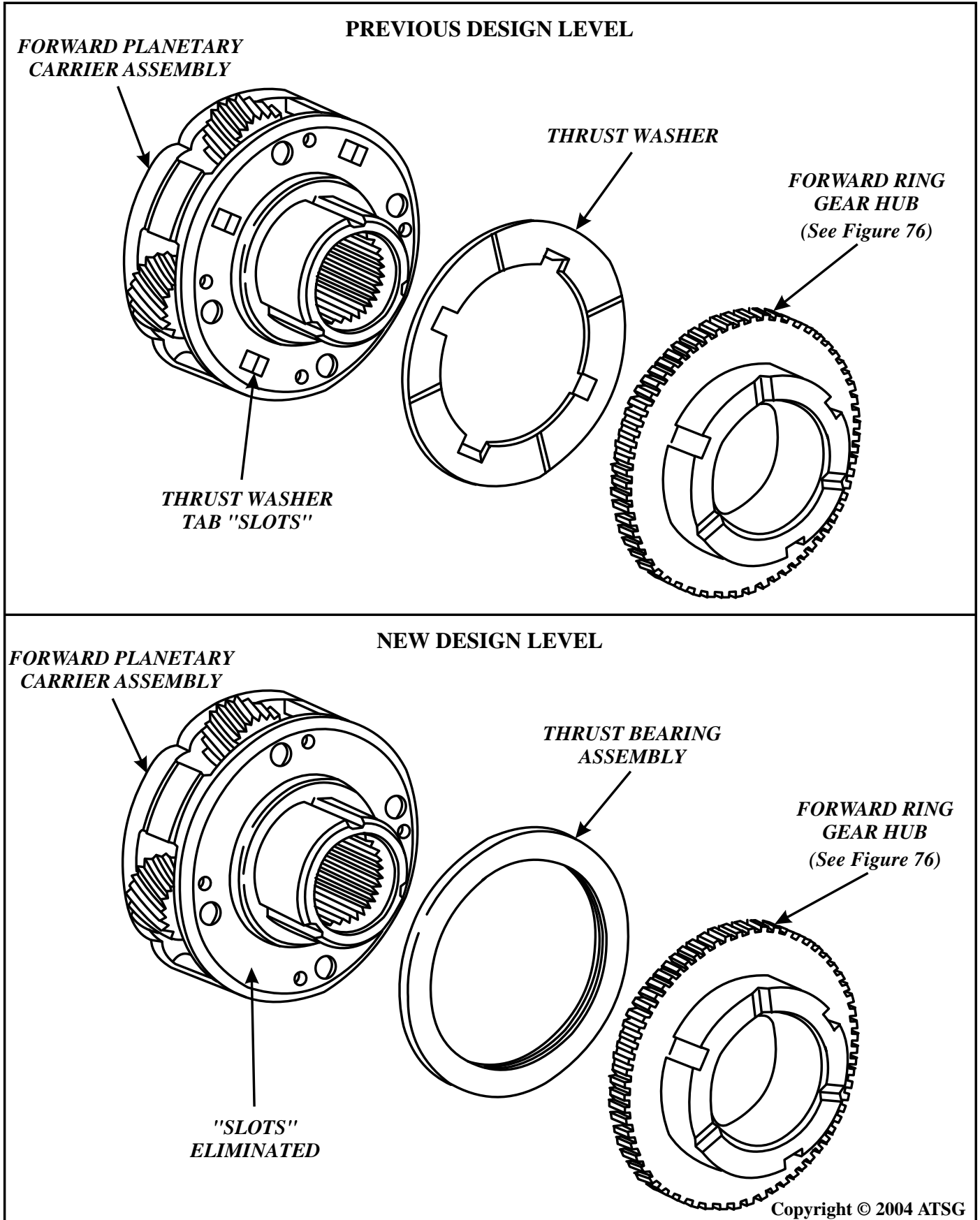


Figure 77



**FORD E4OD
NEW DESIGN OVERDRIVE PISTON**

CHANGE: Some 1996-1997 vehicles equipped with the E4OD transmission were built with a new design level overdrive clutch piston, with the seals bonded to the piston (See Figure 78).

REASON: Increased durability and cost savings in the manufacturing process.

PARTS AFFECTED:

- (1) OVERDRIVE PISTON - Now stamped steel with moulded rubber inner and outer seals on the piston assembly, instead of the previous machined aluminum, as shown in Figure 78.
- (2) OVERDRIVE/INTERMEDIATE CLUTCH CYLINDER - Major casting changes to clutch cylinder, to accommodate the new design level bonded piston, as shown in Figure 78.

INTERCHANGEABILITY:

Both pieces listed above *will* retro-fit back on all previous models of the E4OD transmission, but *must* be used together as a package. New design parts *are not* interchangeable with previous design level parts on an individual basis.

Note: Until the new design level parts are fully stocked, the current service parts must be used to replace the new design level parts, if it becomes necessary to replace either the new design bonded seal piston or new design cylinder.

SERVICE INFORMATION:

Overdrive Piston Assembly (New Design)	F6TZ-7A262-AA
O.D./Int. Cylinder Assembly (New Design)	F6TZ-7G384-AA
Overdrive Piston Assembly (Previous Design)	E9TZ-7A262-A
Inner Piston Seal (Previous Design)	E9TZ-7F225-A
Outer Piston Seal (Previous Design)	E9TZ-7A548-A
O.D./Int. Cylinder Assembly (Previous Design)	E9TZ-7G384-B

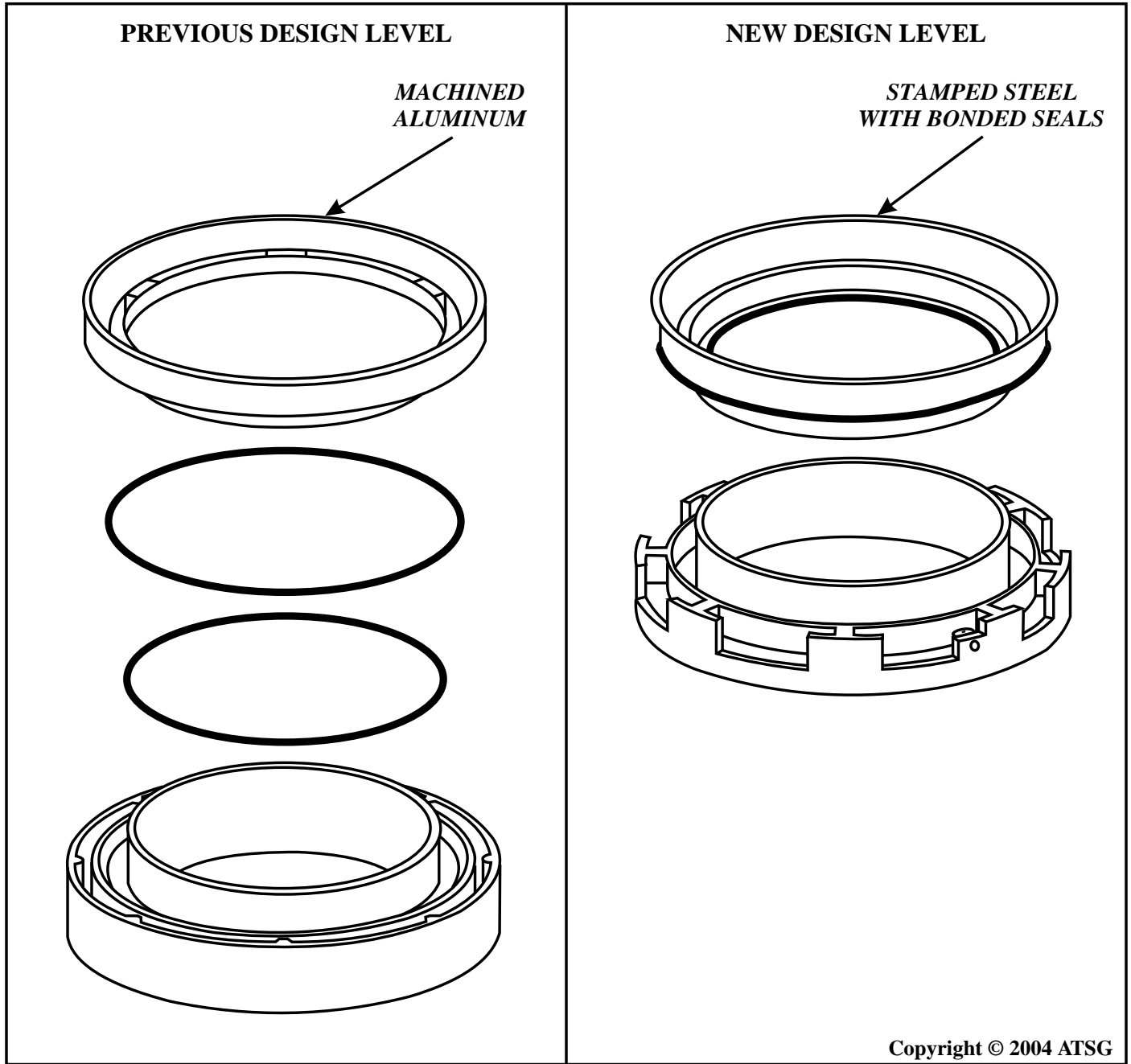


Figure 78



**FORD E4OD
COOLER BYPASS VALVE ADDED
TO SOME 1997 MODELS**

CHANGE: Some 1997 Econoline, Expedition, F-150 Trucks and F-250 Trucks have been equipped with a Cooler Bypass Valve Assembly that requires sealing washers on both the "To Cooler" end and "From Cooler" end of the bypass valve assembly, as shown in Figure 79.

REASON: Increased lube flow during cold weather operation.

PARTS AFFECTED:

- (1) COOLER BYPASS VALVE ASSEMBLY - Added between the cooler line fittings in the case, to increase lube flow during cold weather operation (See Figure 79).
- (2) CASE FITTINGS - Requires special case fittings to retain the "Banjo" ends of the cooler bypass valve assembly into the transmission case (See Figure 79).
- (3) SEALING WASHERS - Requires sealing washers on both of the "Banjo" ends of the cooler bypass valve to seal properly (See Figure 79).

INTERCHANGEABILITY:

The new design Cooler Bypass Valve Assembly will retro-fit back to all previous models, and we would recommend the 4R100 style bypass valve assembly, as shown in Figure 79, because you do not have to bend the existing cooler line to get it hooked up.

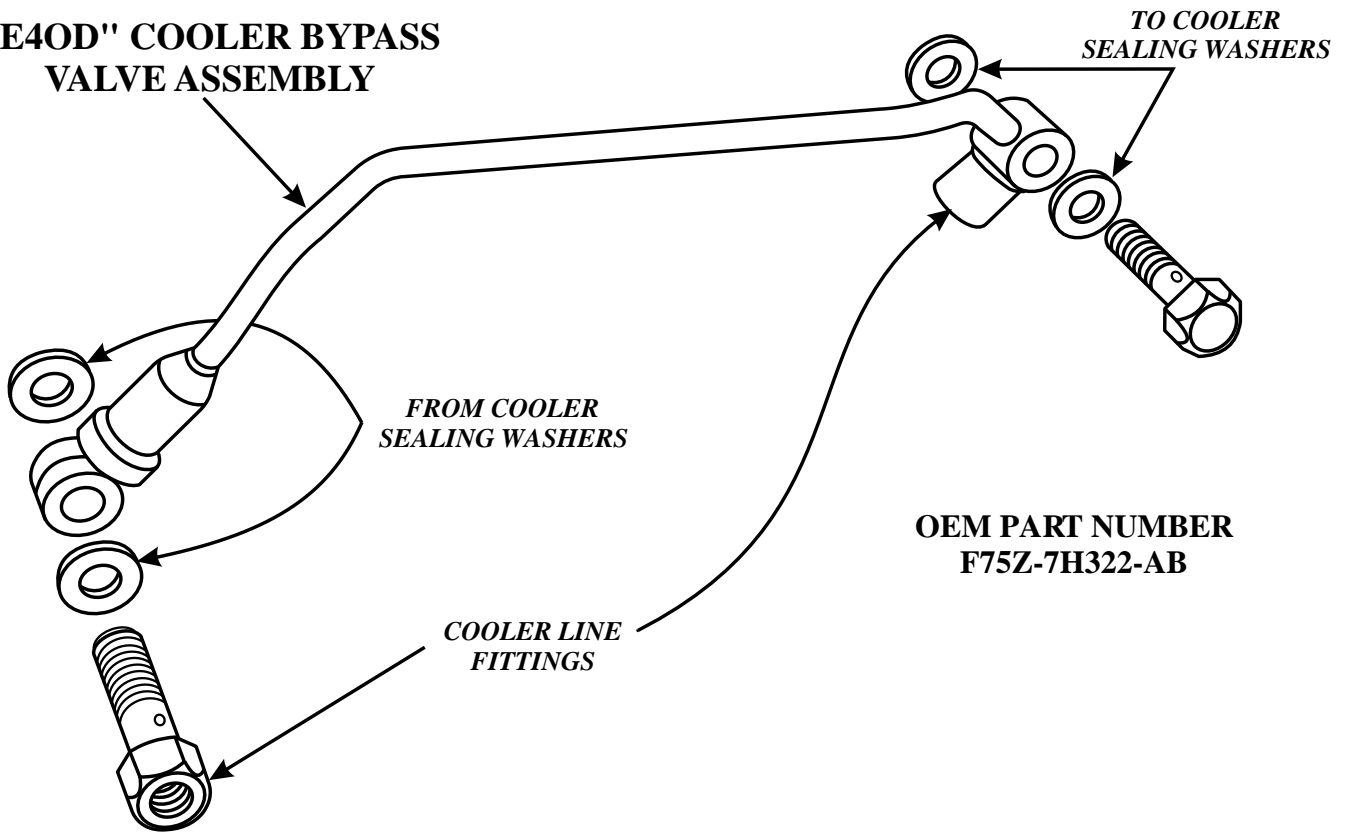
SERVICE INFORMATION:

Cooler Bypass Valve Assembly (E4OD Style)	F75Z-7H322-AB
Cooler Bypass Valve Assembly (4R100 Style)	F81Z-7H322-AA
Cooler Bypass Valve Sealing Washer Kit	391933

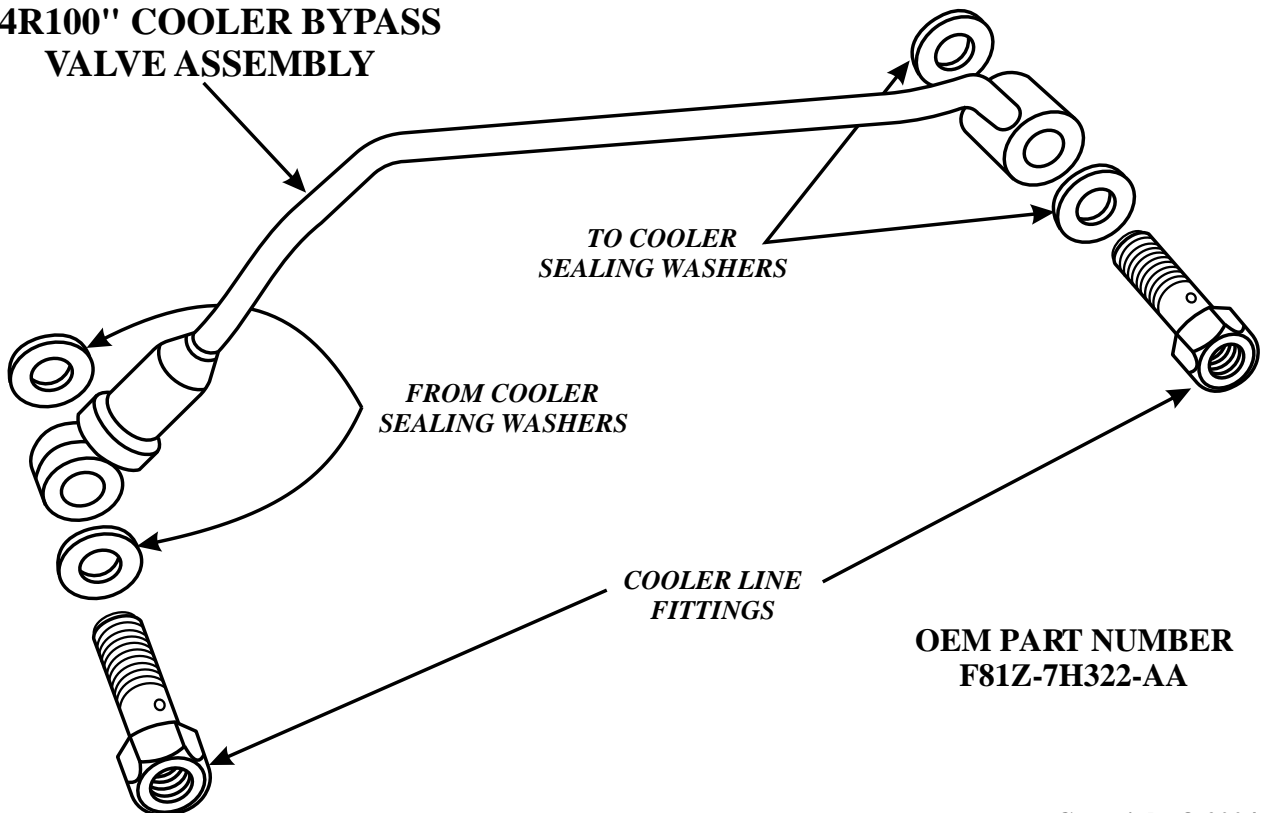
SPECIAL SERVICE NOTE:

If a removed Cooler Bypass Valve has an "O" ring installed, remove the "O" ring prior to re-installing the assembly. The "O" rings are only used to hold the sealing washers in place for shipping purposes. If the entire Cooler Bypass Valve requires replacement, be sure to remove the shipping caps and "O" rings prior to installation.

**"E4OD" COOLER BYPASS
VALVE ASSEMBLY**



**"4R100" COOLER BYPASS
VALVE ASSEMBLY**



Copyright © 2004 ATSG

Figure 79



Technical Service Information

FORD E4OD ADDED LUBE ORIFICE PLUG FOR SOME 1997 MODELS

CHANGE: Beginning on 7/24/97, a new design transmission case and extension housing were released for production for 1997 model Econoline, Expedition, F Super Duty, F150-350 Series Trucks and 1998 Navigator vehicles. (See Figures 80 and 81).

REASON: Improved lubrication distribution to extension housing bushing.

PARTS AFFECTED:

- (1) TRANSMISSION CASE - Added passage at the rear of transmission case to accept the added plastic lube orifice plug, as shown in Figure 80.
- (2) EXTENSION HOUSING - Added cast-in shoulder/boss that retains the added lube orifice plug in the transmission case, as shown in Figure 81.

INTERCHANGEABILITY: (97-23-13)

- (1) The new design extension housing *with* the added cast-in shoulder or boss will service *any* E4OD transmission case, past or present (See Figure 81).
- (2) The previous design extension housing *without* the cast-in shoulder or boss can only be used on transmission cases built prior to 7/24/97 not having the lube orifice plug (See Figure 81).

SERVICE INFORMATION:

Extension Housing, 5.4L, 6.8L, 7.3L, 2 Wheel Drive	F85Z-7A039-DA
Extension Housing, 4 Wheel Drive	F7TZ-7A039-AA
Extension Housing, Super Duty	F7UZ-7A039-BA
Transmission Case, 5.4L, 6.8L	F75Z-7005-BB
Transmission Case, 7.3L	F7UZ-7005-BA
Lube Orifice Plug, All	F81Z-7E380-AA

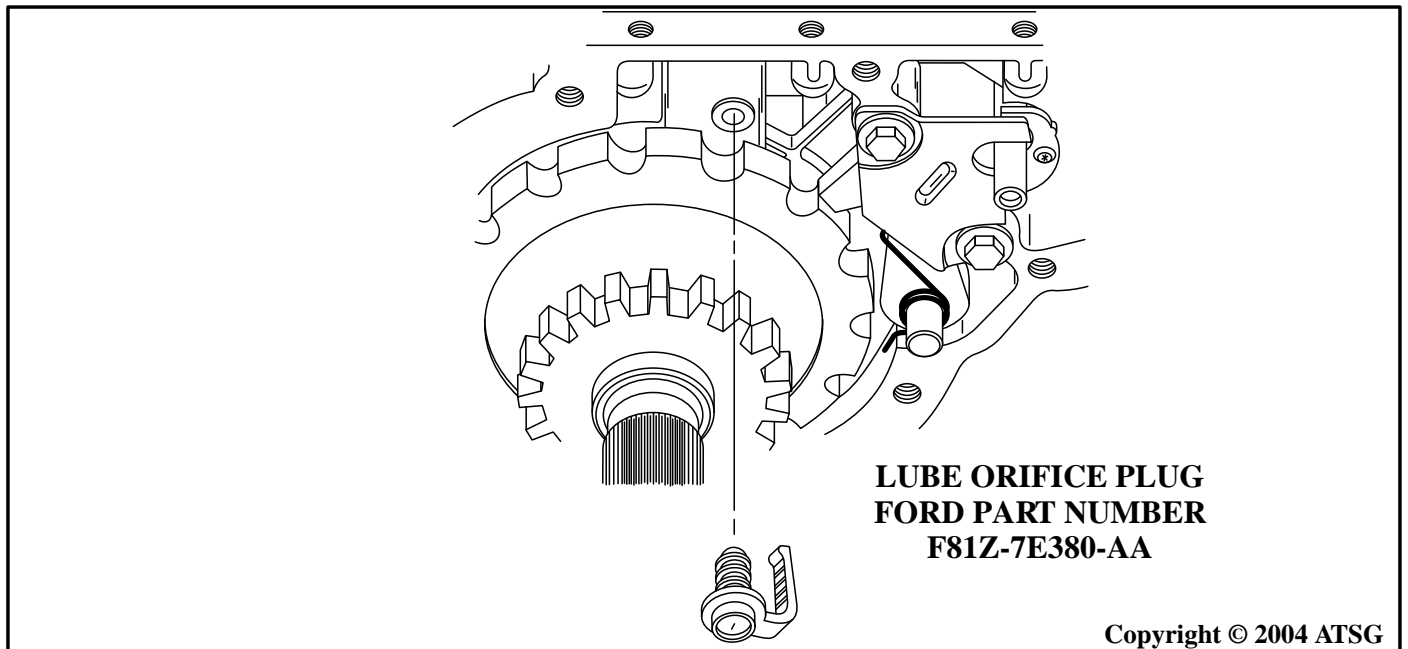
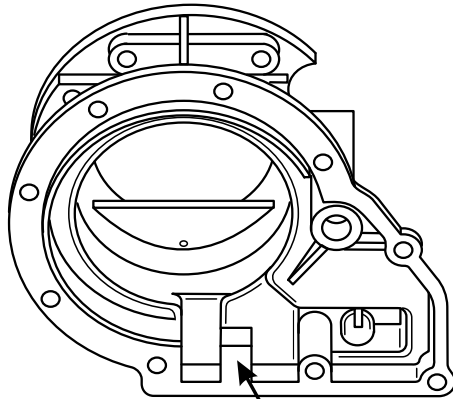


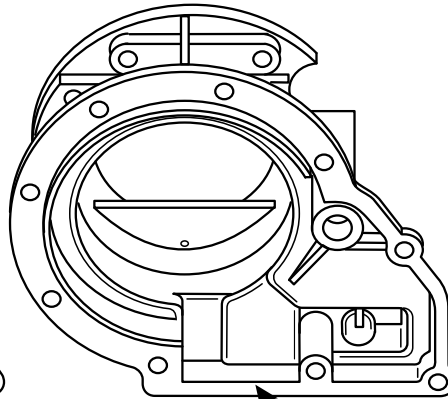
Figure 80

**TYPICAL
4 WHEEL DRIVE**



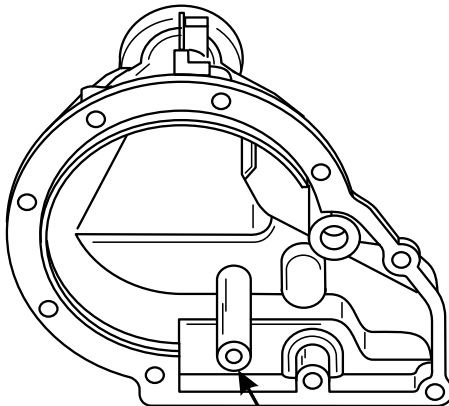
SHOULDER

**E4OD 4X4 WITHOUT
LUBE PLUG**



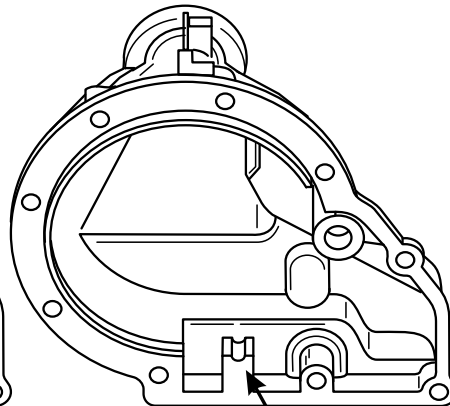
NO SHOULDER

**FORD 4R100
6.8L AND 7.3L
2 WHEEL DRIVE**



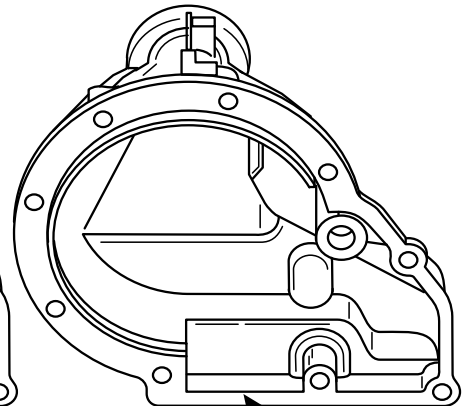
ADDED BOSS

**ALL OTHER
2 WHEEL DRIVE
APPLICATIONS**



SHOULDER

**E4OD WITHOUT
LUBE PLUG**



NO SHOULDER

Figure 81



FORD E4OD/4R100 NEW FRONT PUMP ASSEMBLY FOR 1997-1998 MODELS

CHANGE: Ford Motor Company for the 1999 Model Year, has renamed the E4OD transmission when they added the PTO window to the case. Many changes were made to the internal parts including the Oil Pump Assembly. These new oil pumps have now been found in some models of the 1997-1998 E4OD transmissions, from the factory assembly line.

REASON: Preparing the Oil Pump Assembly to accommodate two different converter clutch valve line-ups, and two different coast clutch housings.

PARTS AFFECTED:

- (1) OIL PUMP BODY - Now has different worm tracks to accommodate the new pump cover assembly and is identified by the rough forging number RF-F81P-7A105-AA, and is cast into the pump body in the location shown in Figure 82. The worm track side of the new pump body and the previous pump body are shown in Figure 83.
- (2) OIL PUMP COVER - Now has different worm tracks to accommodate two different styles of converter clutch valve line-ups, and has one added bolt to clamp the pump halves together. The worm track side of the new pump cover and the previous pump cover are illustrated in Figure 84, and casting number on new pump cover is RF-F81P-7B324-AA for identification.
- (3) TCC LINE-UP - There are now two different Converter Clutch Control Valve Line-Ups in the oil pump cover depending on whether it is gasoline or diesel engine. Both of these valve line-ups are illustrated in Figure 85.
- (4) STATOR SHAFT ASSEMBLY - There are now two different Stator Shaft Assemblies with different sealing ring configurations, to accommodate the new coast clutch housing, as illustrated in Figure 86, and are model dependent.
- (5) COAST CLUTCH HOUSING - There is now a "stamped Steel" coast clutch housing that may or may not have a PTO gear pressed onto the housing, that is used in addition to the previous cast iron coast clutch housing, depending on the model and engine size, and is illustrated in Figure 87. This also changes the coast clutch steel plates and the fourth clutch friction plates, as shown in Figures 87 and 88.

INTERCHANGEABILITY:

This new Oil Pump Assembly will retro-fit back to previous models, as long as you have the proper valve line-up in the converter clutch control valve bore. The pump halves *cannot* be inter-mixed because of the major worm track differences. All other parts listed above are model dependent and *great care must be used* when parts replacement is necessary.

1998 E4OD PUMP BODY
FRONT SIDE

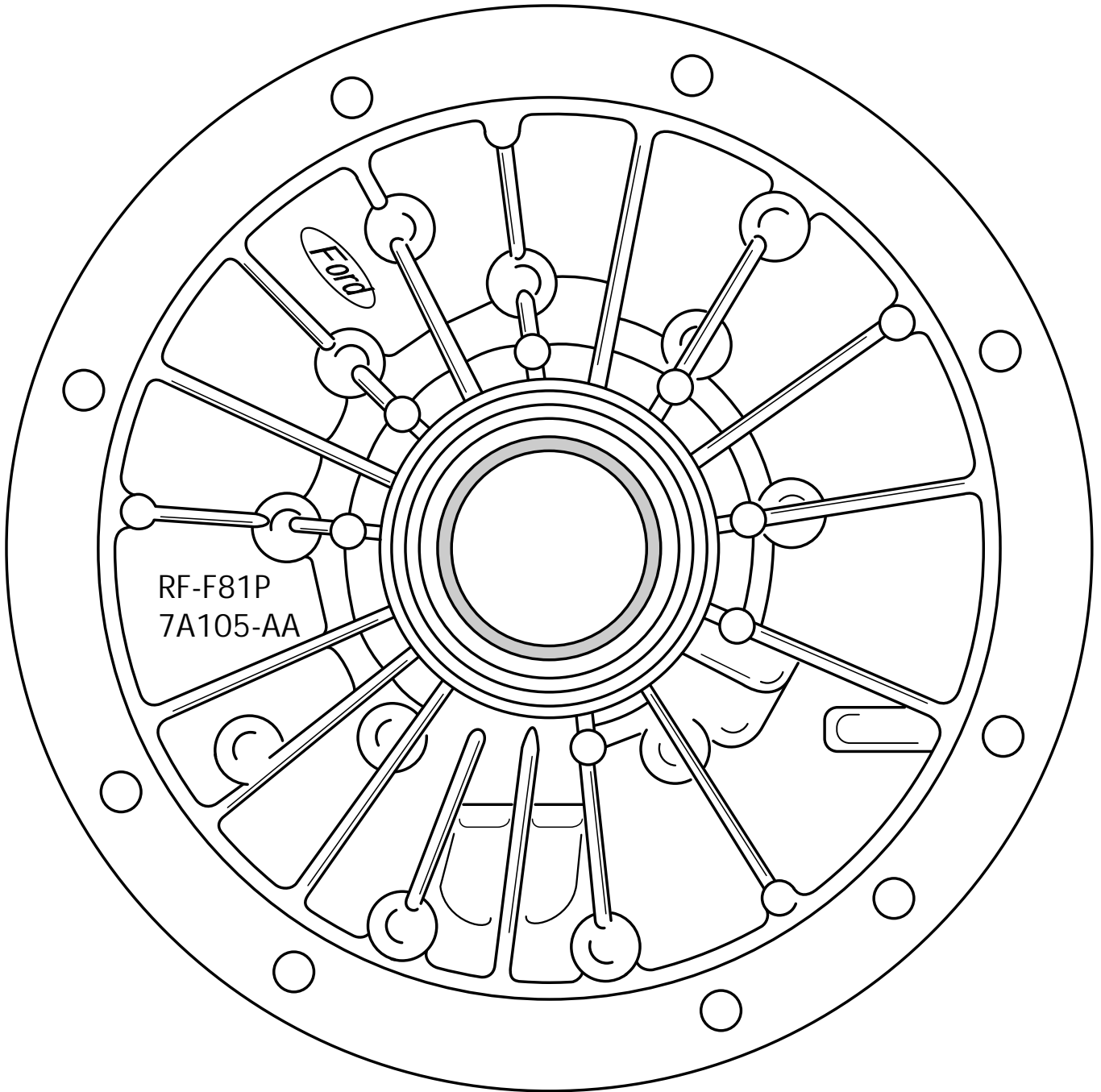
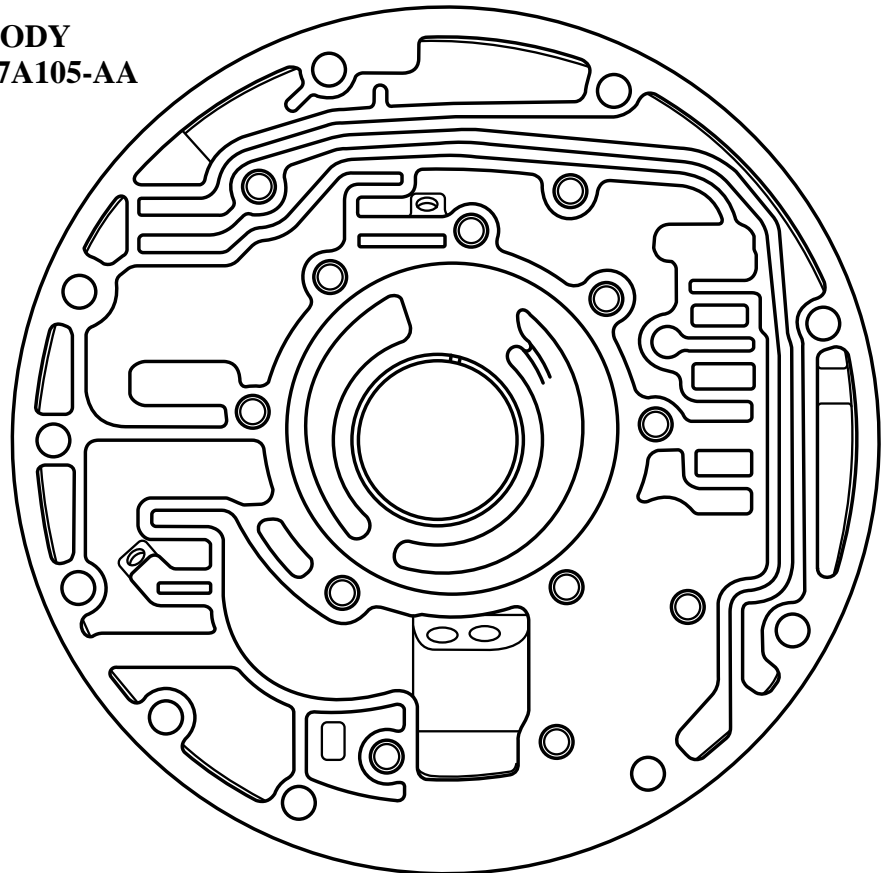
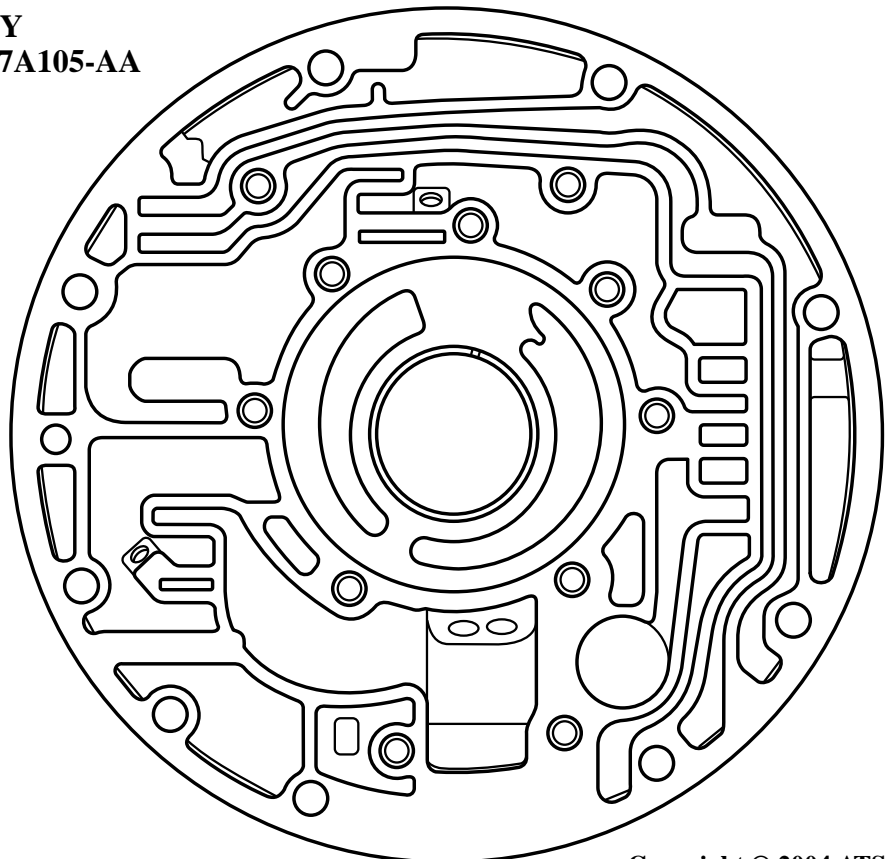


Figure 82
AUTOMATIC TRANSMISSION SERVICE GROUP

1998 E4OD/4R100 PUMP BODY
CASTING NUMBER RF-F81P-7A105-AA
WORM TRACK SIDE



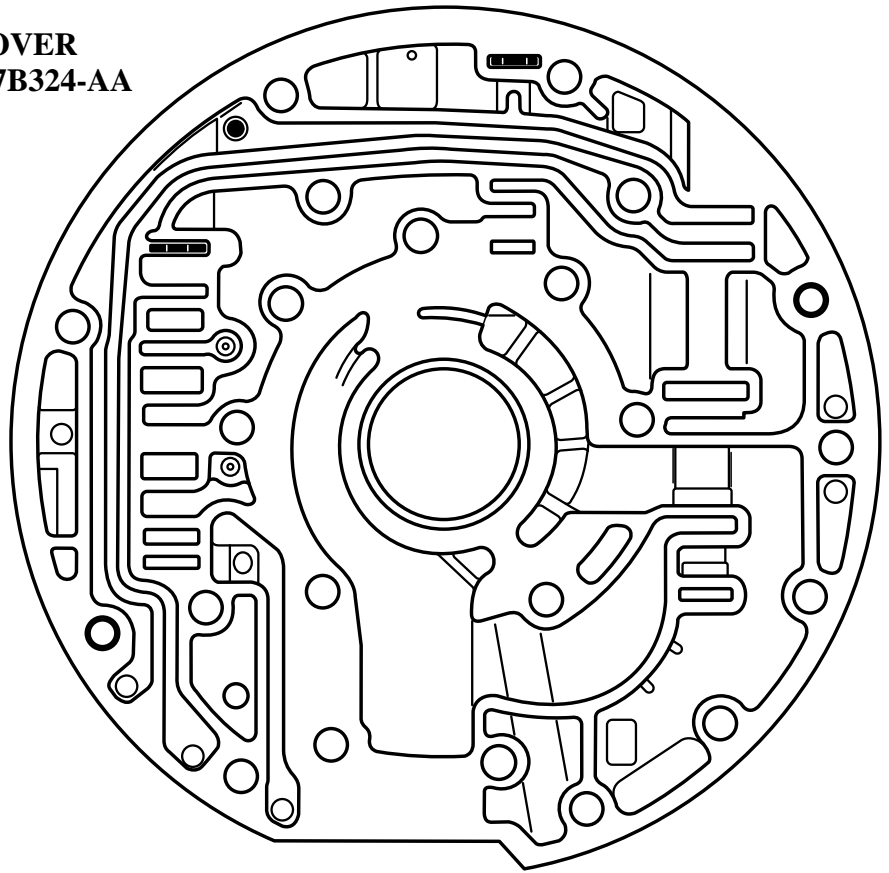
1995 E4OD PUMP BODY
CASTING NUMBER RF-F5TP-7A105-AA
WORM TRACK SIDE



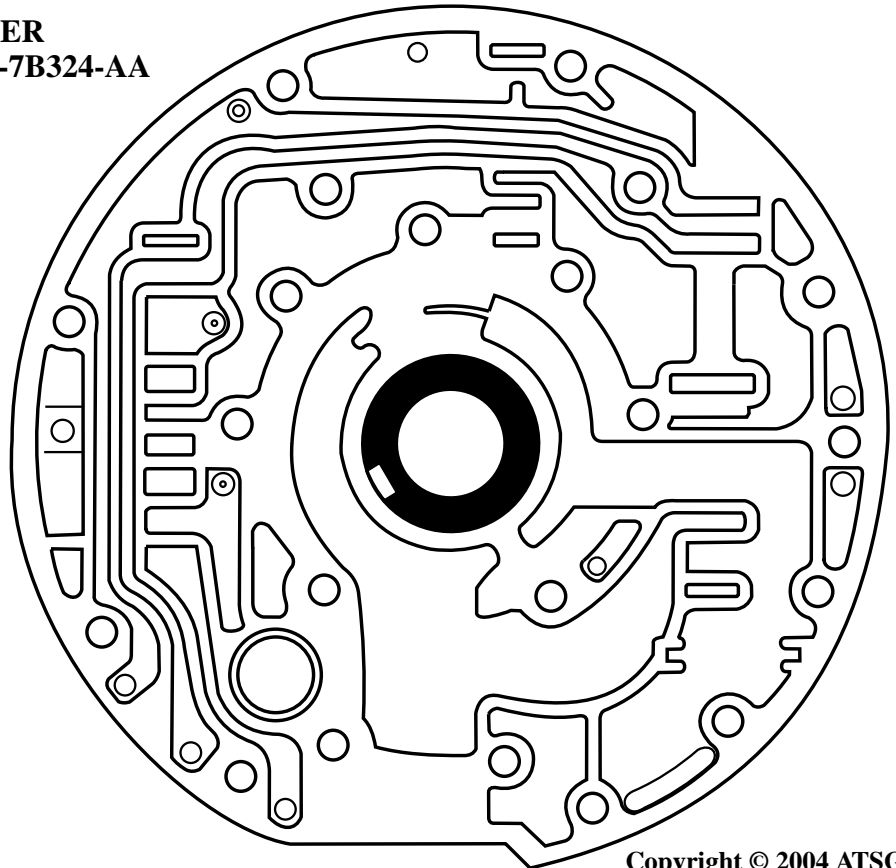
Copyright © 2004 ATSG

Figure 83
AUTOMATIC TRANSMISSION SERVICE GROUP

1998 E4OD/4R100 PUMP COVER
CASTING NUMBER RF-F81P-7B324-AA



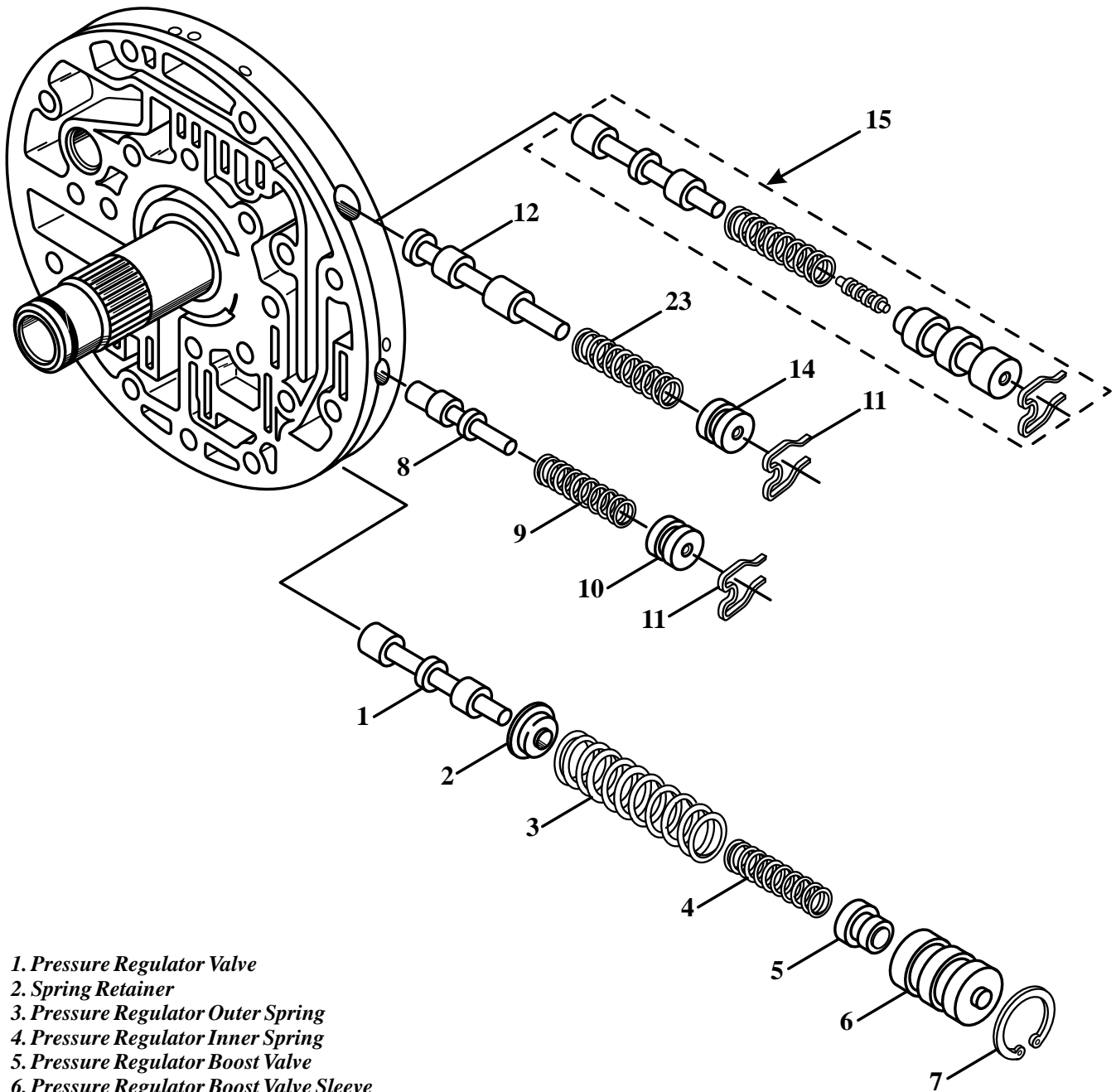
1995 E4OD PUMP COVER
CASTING NUMBER RF-F5TP-7B324-AA



Copyright © 2004 ATSG

Figure 84
AUTOMATIC TRANSMISSION SERVICE GROUP

FORD E4OD/4R100 VALVE LINE-UPS IN PUMP ASSEMBLY

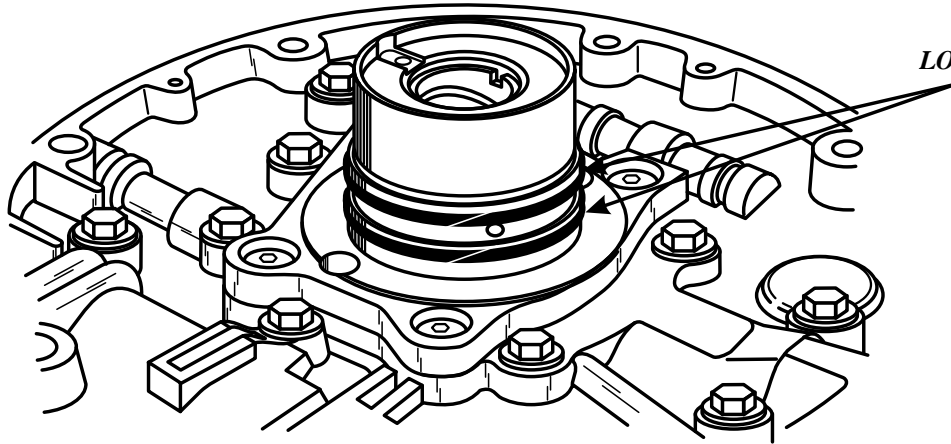


1. Pressure Regulator Valve
2. Spring Retainer
3. Pressure Regulator Outer Spring
4. Pressure Regulator Inner Spring
5. Pressure Regulator Boost Valve
6. Pressure Regulator Boost Valve Sleeve
7. Snap Ring
8. Converter Clutch Regulator Valve
9. Converter Clutch Regulator Spring
10. Converter Clutch Regulator Bore Plug
11. Bore Plug Retainer
12. Converter Clutch Control Valve (Gas "On-Off" Only)
13. Converter Clutch Control Spring (Gas "On-Off" Only)
14. Converter Clutch Control Bore Plug
15. Converter Clutch Control Line-up (Diesel "PWM" Only)

Copyright © 2004 ATSG

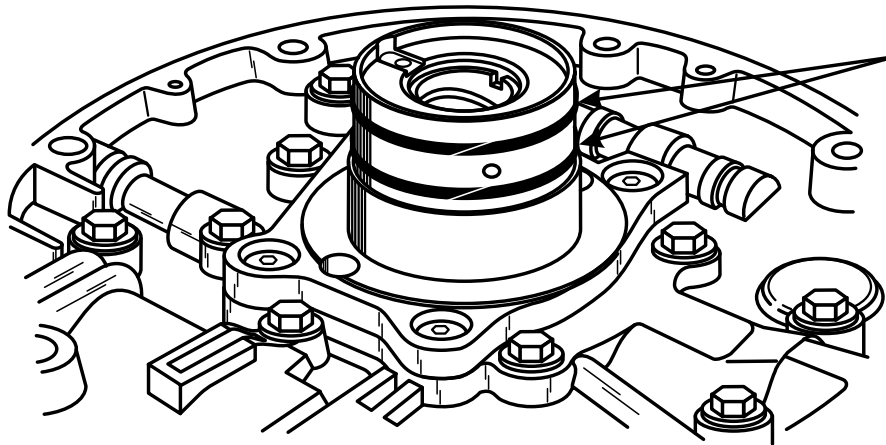
Figure 85

AUTOMATIC TRANSMISSION SERVICE GROUP



*COAST CLUTCH
SEAL RINGS ARE
LOW ON PUMP TOWER*

**USED WITH THE "CAST IRON" COAST CLUTCH DRUM
WITH 5.4L AND 6.8L "WITHOUT" PTO OPTION**

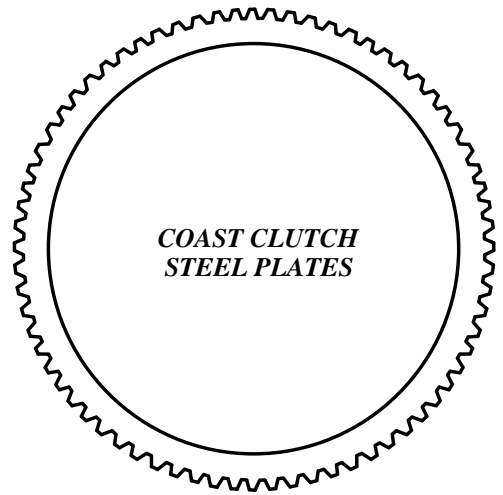
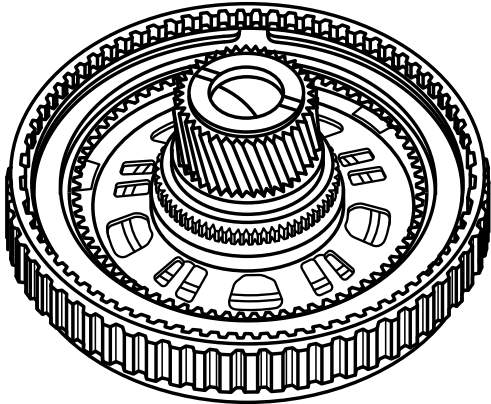


*COAST CLUTCH
SEAL RINGS ARE HIGHER
ON THE PUMP TOWER*

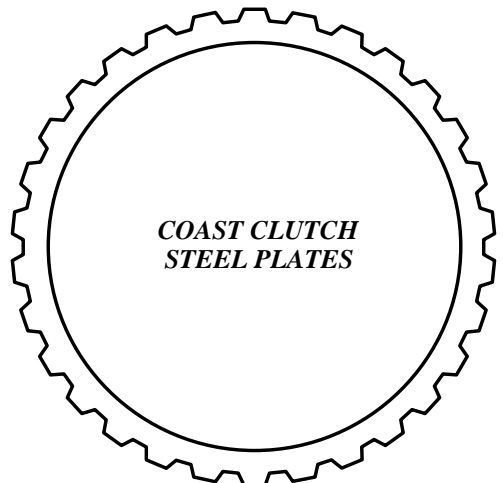
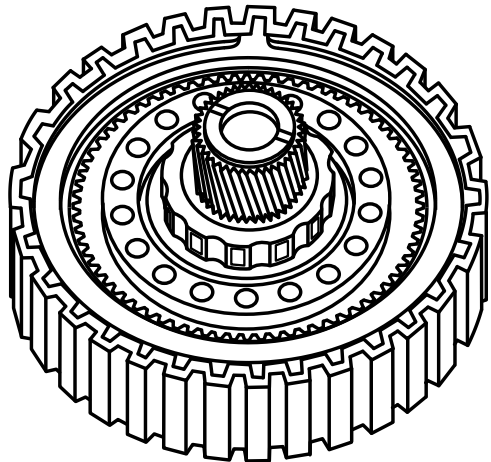
**USED WITH THE "STAMPED STEEL" COAST CLUTCH DRUM
WITH 5.4L AND 6.8L "WITHOUT" PTO OPTION**

Copyright © 2004 ATSG

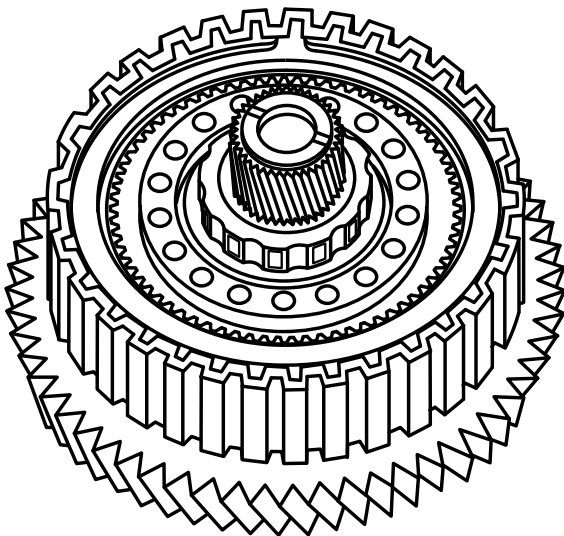
Figure 86



**"CAST IRON" COAST CLUTCH DRUM USED
WITH 5.4L AND 6.8L "WITHOUT" PTO OPTION**



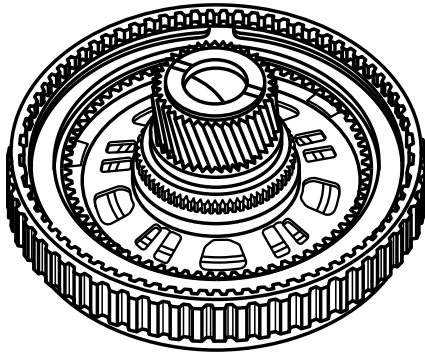
**"STAMPED STEEL" COAST CLUTCH DRUM USED
WITH 5.4L AND 6.8L "WITHOUT" PTO OPTION**



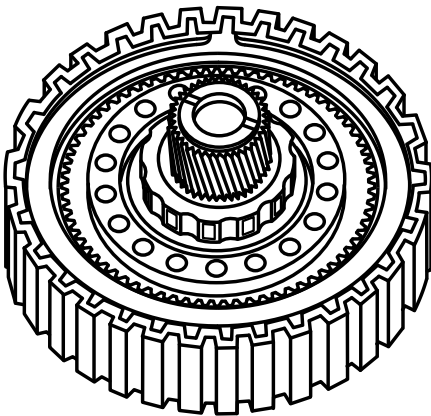
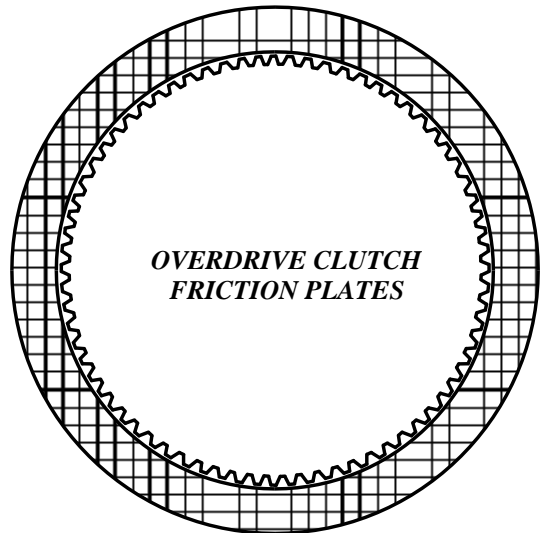
**"STAMPED STEEL" COAST CLUTCH DRUM USED
WITH 6.8L AND 7.3L "WITH" PTO OPTION**

Copyright © 2004 ATSG

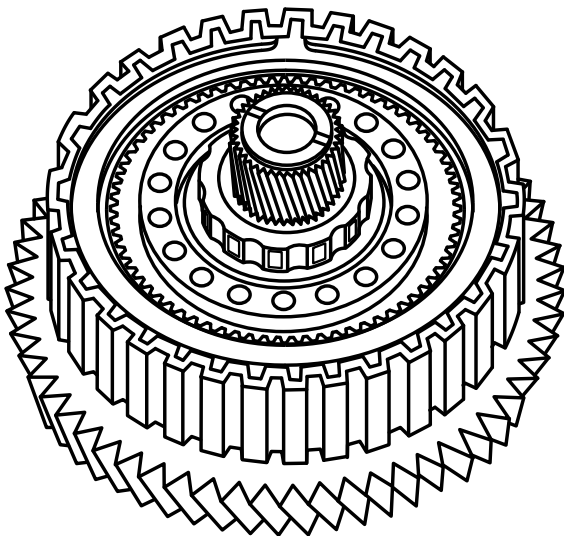
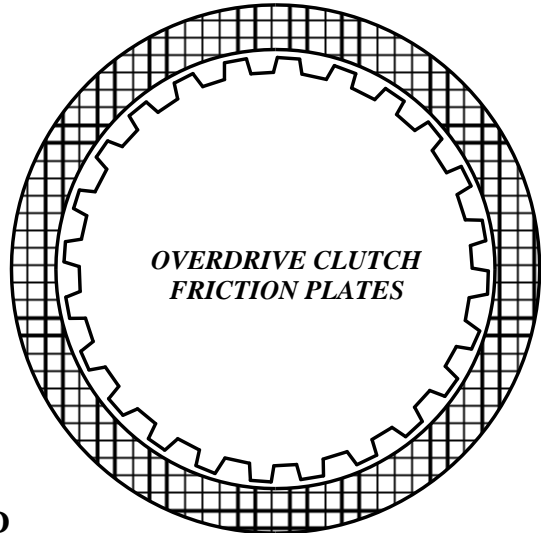
Figure 87



"CAST IRON" COAST CLUTCH DRUM USED WITH 5.4L AND 6.8L "WITHOUT" PTO OPTION



"STAMPED STEEL" COAST CLUTCH DRUM USED WITH 5.4L AND 6.8L "WITHOUT" PTO OPTION



"STAMPED STEEL" COAST CLUTCH DRUM USED WITH 6.8L AND 7.3L "WITH" PTO OPTION

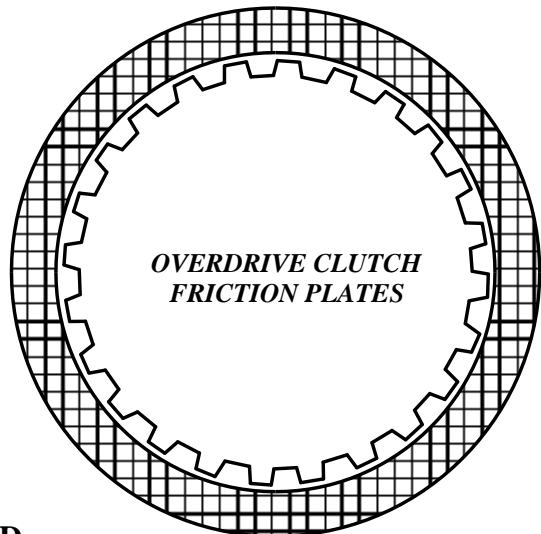


Figure 88



**FORD E4OD/4R100
NEW DESIGN 6 PINION
FORWARD AND REVERSE PLANETARY CARRIER**

CHANGE: Beginning at the start of production for all 1998 model E4OD transmissions, *some models* will be equipped with a new design 6 pinion forward planetary carrier, and a new design 6 pinion reverse planetary carrier, as shown in Figure 89.

REASON: Increased torque carrying capacity and increased planetary carrier durability.

PARTS AFFECTED:

- (1) FORWARD PLANETARY CARRIER - Now has 6 pinions instead of the previous 4 pinions for increased torque carrying capacity and increased durability (See Figure 89).
- (2) REVERSE PLANETARY CARRIER - Now has 6 pinions instead of the previous 4 pinions for increased torque carrying capacity and increased durability (See Figure 89).

INTERCHANGEABILITY:

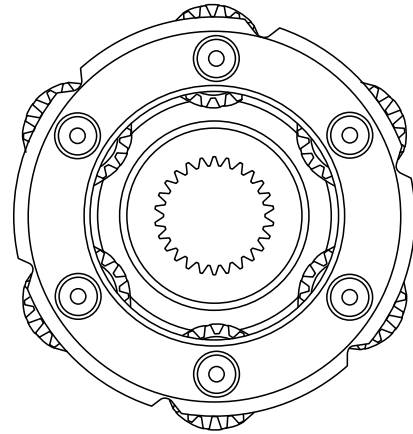
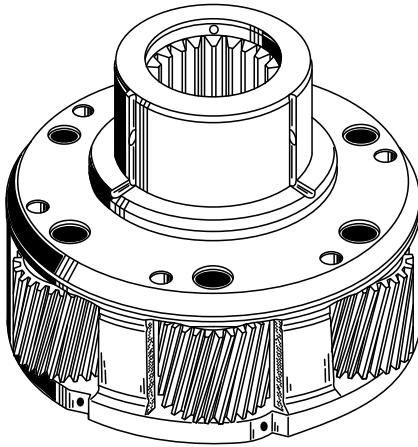
The new design forward planetary carrier *will back service all models* of the E4OD, but it *does require* the latest design forward ring gear hub and bearing assembly, as there are no holes for the previous design thrust washer (See Figure 89).

The new design reverse planetary carrier *will back service all models* of the E4OD, but it *does require* the latest design reverse clutch hub and three tang thrust washer for both sides, as shown in Figure 89.

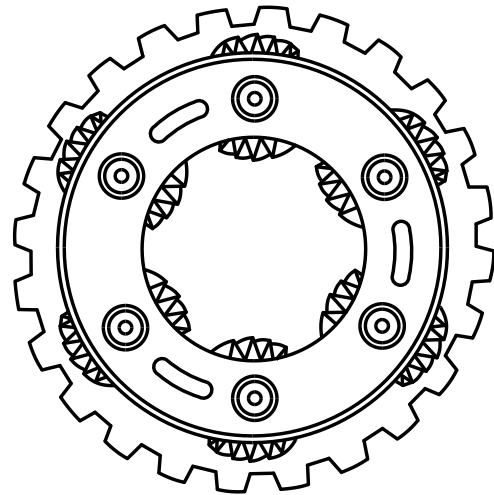
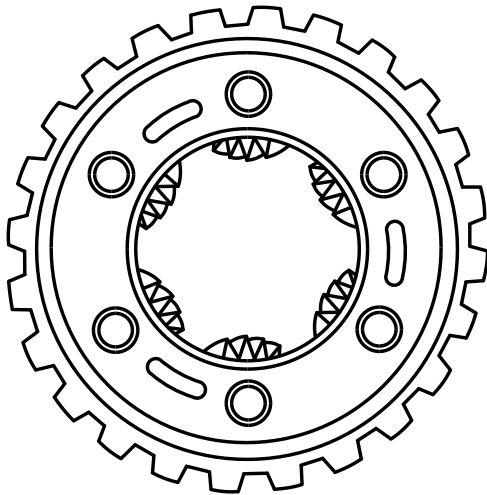
SERVICE INFORMATION:

Forward Planetary Carrier (6 Pinion)	F81Z-7A398-CA
Reverse Planetary Carrier (6 Pinion)	F81Z-7D006-AA

**NEW DESIGN 6 PINION FORWARD PLANETARY CARRIER
PART NUMBER F81Z-7A398-CA**



**NEW DESIGN 6 PINION REVERSE PLANETARY CARRIER
PART NUMBER F81Z-7D006-AA**



**REQUIRES 1997-UP DESIGN LEVEL
REVERSE CLUTCH HUB ASSEMBLY**

**REQUIRES 3 TANG THRUST WASHERS
ON BOTH SIDES OF REAR CARRIER
PART NUMBER F0TZ-7A166-D**

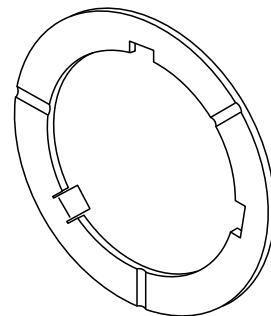
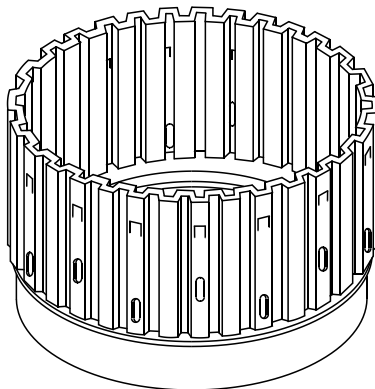


Figure 89



**FORD E4OD/4R100
NEW DESIGN SUN SHELL**

CHANGE: There is now a new design Sun Shell with "Tabs" added to the center of the sun shell slots, as shown in Figure 90, implemented by Ford Motor Co. as a running change, during the 2000 model year. This change eliminated the need for the number 8 thrust washer between the forward and direct drums.

REASON: Main reason for this change was cost savings and ease of assembly.

PARTS AFFECTED:

- (1) INPUT SUN SHELL - New design have "Tabs" added to the center of the sun shell slots, as shown in Figure 90, which now support the direct drum for the required clearance between the direct and forward clutch housings, and allows elimination of the number 8 thrust washer, as shown in Figure 92.
- (2) DIRECT CLUTCH HOUSING - Manufactured "Without" slots in the center hub, as they were no longer needed to accept the number 8 thrust washer tabs. Both design direct drums are illustrated in Figure 91, and cut-away in Figure 92.
- (3) NUMBER 8 THRUST WASHER - Eliminated (See Figure 91 and 92).

INTERCHANGEABILITY:

The 1st design Sun Shell is no longer available from Ford Motor Co, as the 2nd design Sun Shell *will* retro-fit back on all models, with or without the number 8 thrust washer.

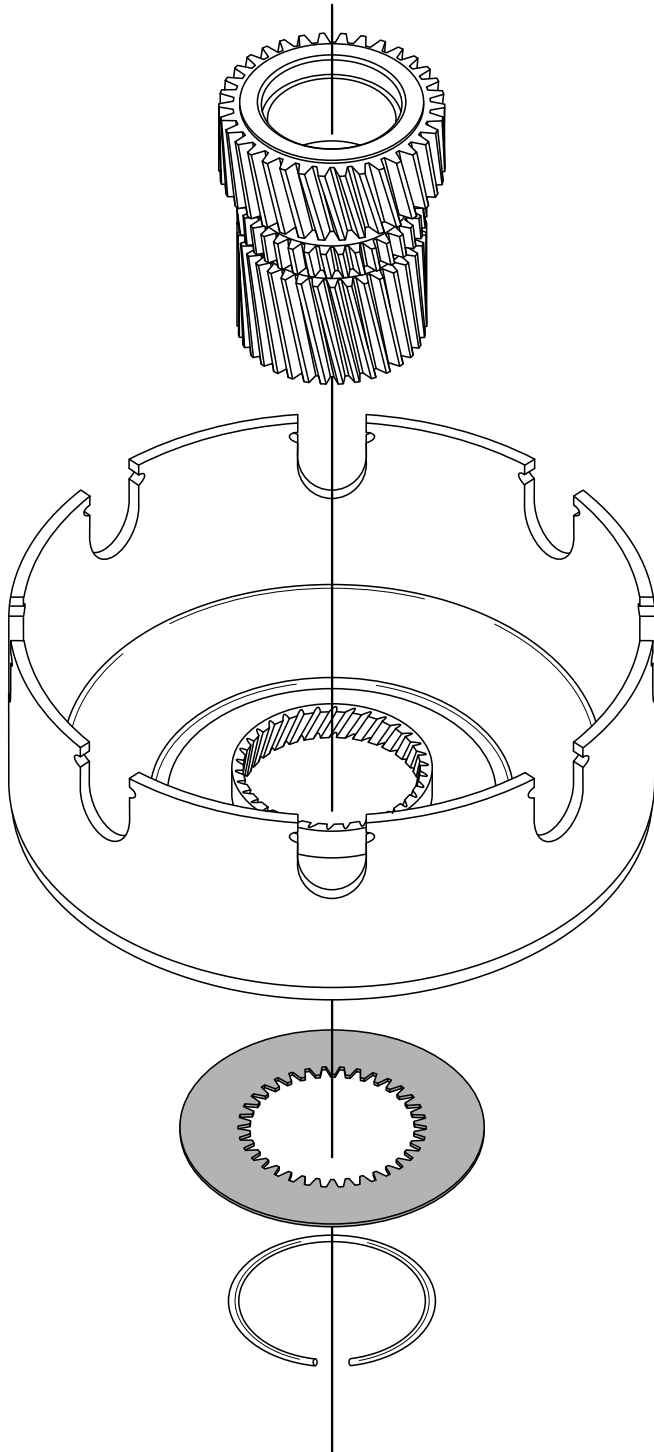
The 2nd design Direct Clutch Housing (No Slots For Washer) *must* be used with the 2nd design Sun Shell, as there are no accommodations for the number 8 thrust washer.

Refer to "Service Information" below for current OEM part numbers.

SERVICE INFORMATION:

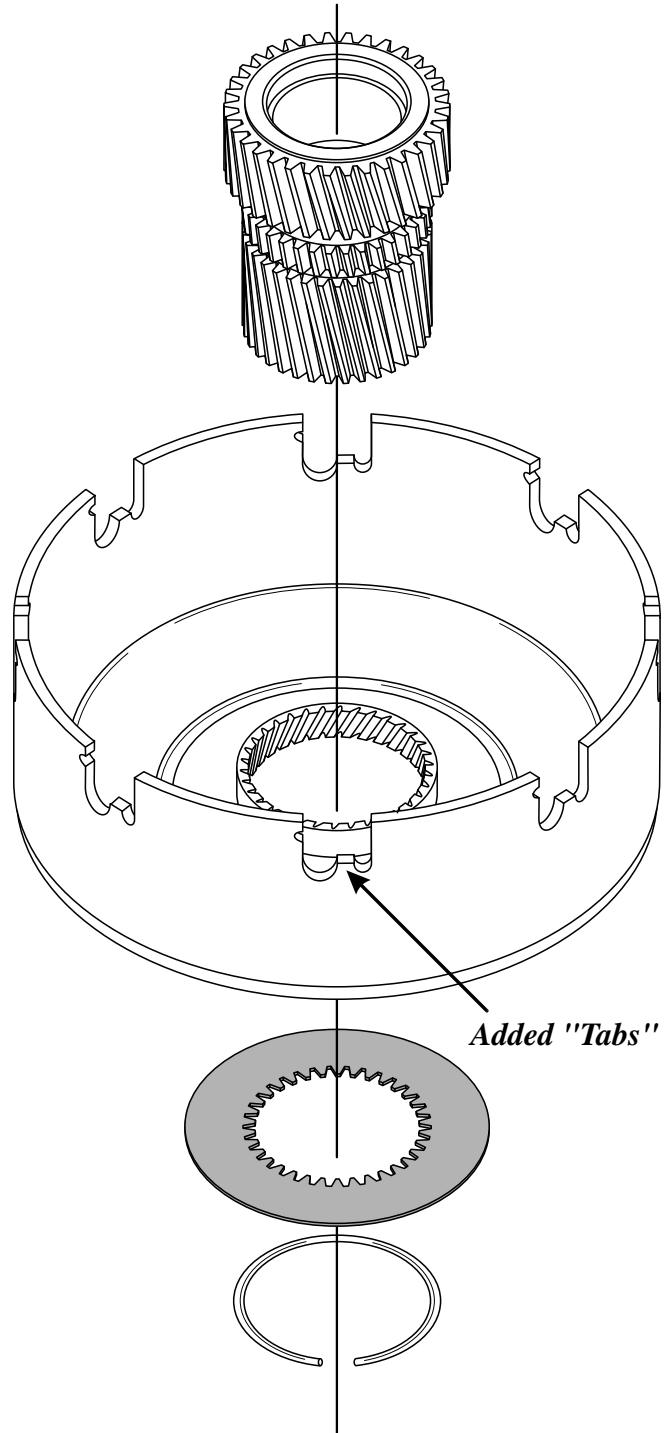
Direct Clutch Housing, 2nd Design (Without 4 Tab Washer)	YC3Z-7D044-BA
Direct Clutch Housing, 1st Design (With 4 Tab Washer)	F81Z-7D044-BA
Sun Shell, Hardened, 2nd Design	YC3Z-7D064-BA
Sun Shell, Regular, 2nd Design	YC3Z-7D064-AA
Direct to Forward Drum (No. 8) 4 Tab Thrust Washer	E9TZ-7C096-A

PREVIOUS DESIGN SUN SHELL
"No Longer Available From Ford"



*May Be Used With "ONLY"
The Previous Design Direct Drum
And Requires The No. 8 Washer
(See Figure 91)*

NEW DESIGN SUN SHELL
*Hardened = YC3Z-7D064-BA
Regular = YC3Z-7D064-AA*

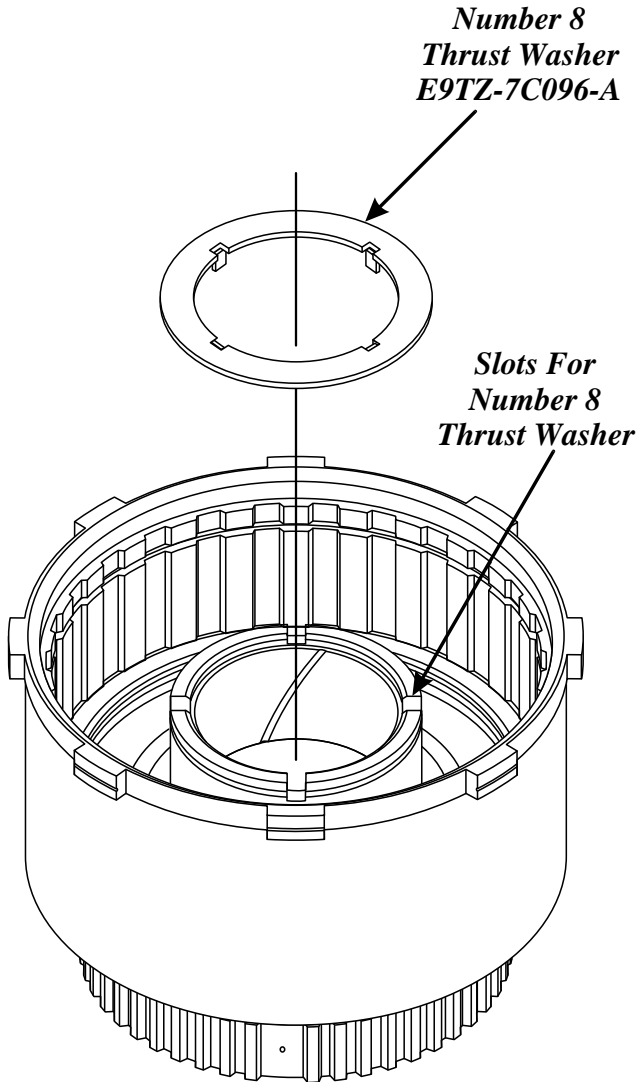


*May Be Used With
Both Design Direct Drums
With Or Without Washer
(See Figure 91)*

Copyright © 2004 ATSG

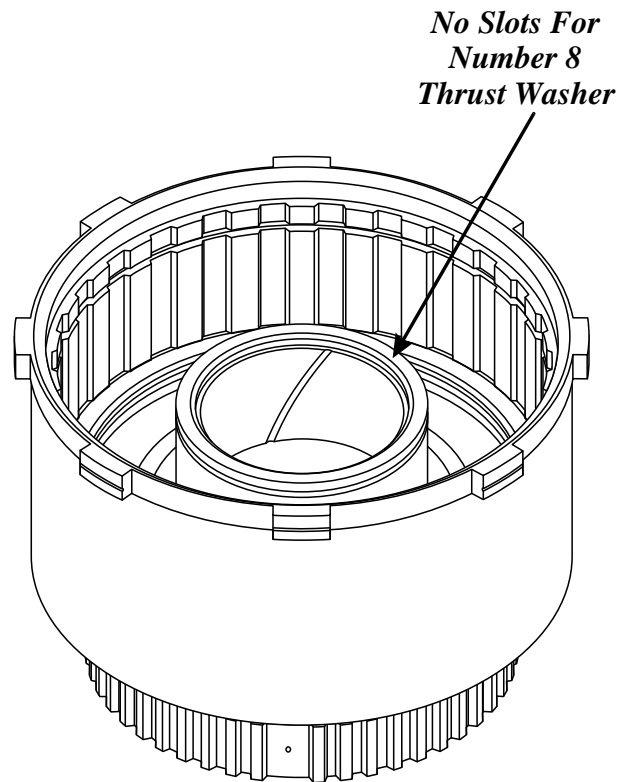
Figure 90

**PREVIOUS DESIGN DIRECT CLUTCH
DRUM "WITH" SLOTS FOR THE
NUMBER 8 THRUST WASHER
PART NO. F81Z-7D044-BA**



*May Be Used With
Both Design Sun Shells
(See Figure 90)*

**NEW DESIGN DIRECT CLUTCH
DRUM "WITHOUT" SLOTS FOR THE
NUMBER 8 THRUST WASHER
PART NO. YC3Z-7D044-BA**



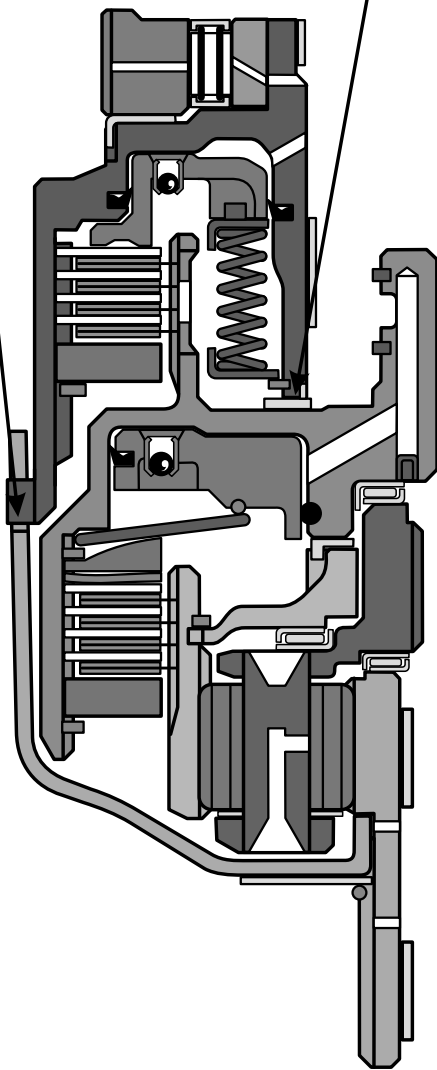
*May Be Used With "ONLY"
The New Design Sun Shell
(See Figure 90)*

Figure 91

**PREVIOUS DESIGN DIRECT CLUTCH
DRUM "WITH" SLOTS FOR THE
NUMBER 8 THRUST WASHER
AND PREVIOUS SUNSHELL**

*When Direct Clutch Housing
Is Not Supported Here,*

*The Number 8 Thrust
Washer Is Required*



**NEW DESIGN DIRECT CLUTCH
DRUM "WITHOUT" SLOTS FOR THE
NUMBER 8 THRUST WASHER
AND NEW SUNSHELL**

*When Direct Clutch Housing
Is Supported By The "Added"
Raised Tabs Here,*

*The Number 8 Thrust
Washer Is Not Required*

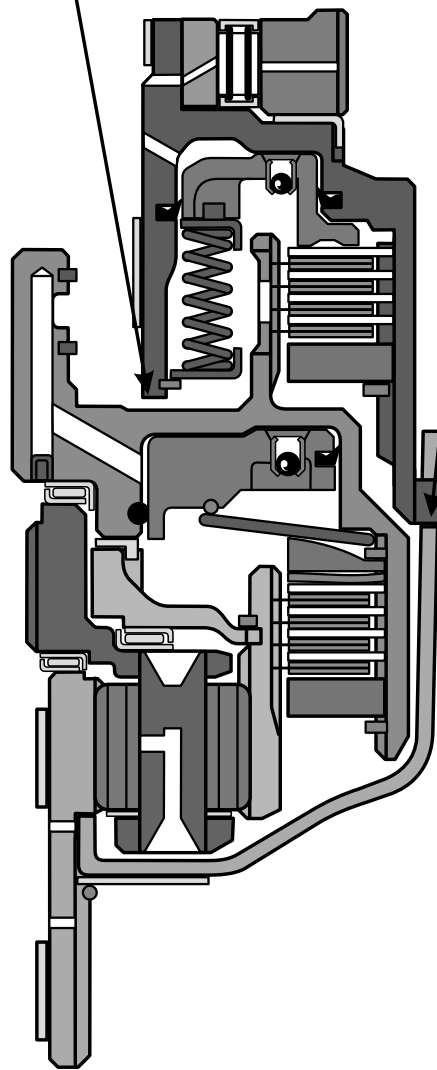


Figure 92



Technical Service Information

INTERMEDIATE ~~FORD~~ **4R100** "DIODE" FREEWHEEL FAILURE

COMPLAINT: Some Ford Motor Company vehicles equipped with the 4R100 transmission may exhibit premature failure of the newly introduced Intermediate "Diode" Freewheel device that was installed in model year 2001 and illustrated in Figure 93.

CAUSE: The cause may be, more than expected load factors.

CORRECTION: The Intermediate "Diode" is *no longer serviced* by Ford Motor Company. The part number now supercedes to all of the previous design level parts, which include the direct clutch housing, intermediate sprag assembly, outer race to direct drum thrust washer, and the intermediate friction plates. All of the previous design level parts are illustrated in Figure 94, with the OEM part numbers. The intermediate frictions must be replaced because the tooth count on the outer race between the diode and the sprag are different.

Special Note: ATSG recommends replacing the Intermediate "Diode" during service, even if it has not yet failed, to protect yourself from possible future failures.

SERVICE INFORMATION:

Direct Clutch Housing, 2nd Design (Without 4 Tab Washer)	YC3Z-7D044-BA
Direct Clutch Housing, 1st Design (With 4 Tab Washer)	F81Z-7D044-BA
Sun Shell, Hardened, 2nd Design	YC3Z-7D064-BA
Sun Shell, Regular, 2nd Design	YC3Z-7D064-BA
Direct to Forward Drum 4 Tab Thrust Washer	E9TZ-7C096-A
Direct Drum to Outer Sprag Race Thrust Washer	E9TZ-7G401-A
Intermediate Sprag Assembly	E9TZ-7A089-B
Intermediate Friction Plates (Special 50 Tooth, 3 Required)	1C3Z-7B164-BA

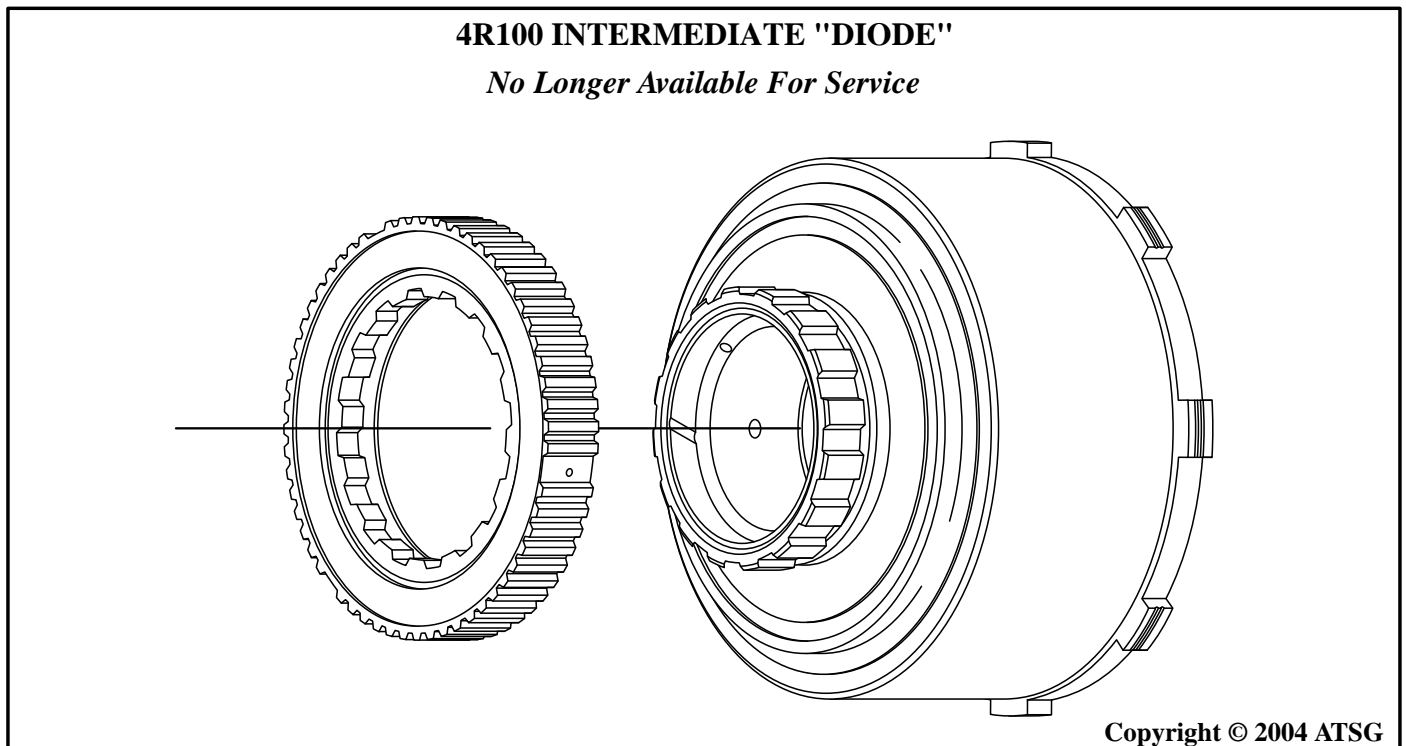
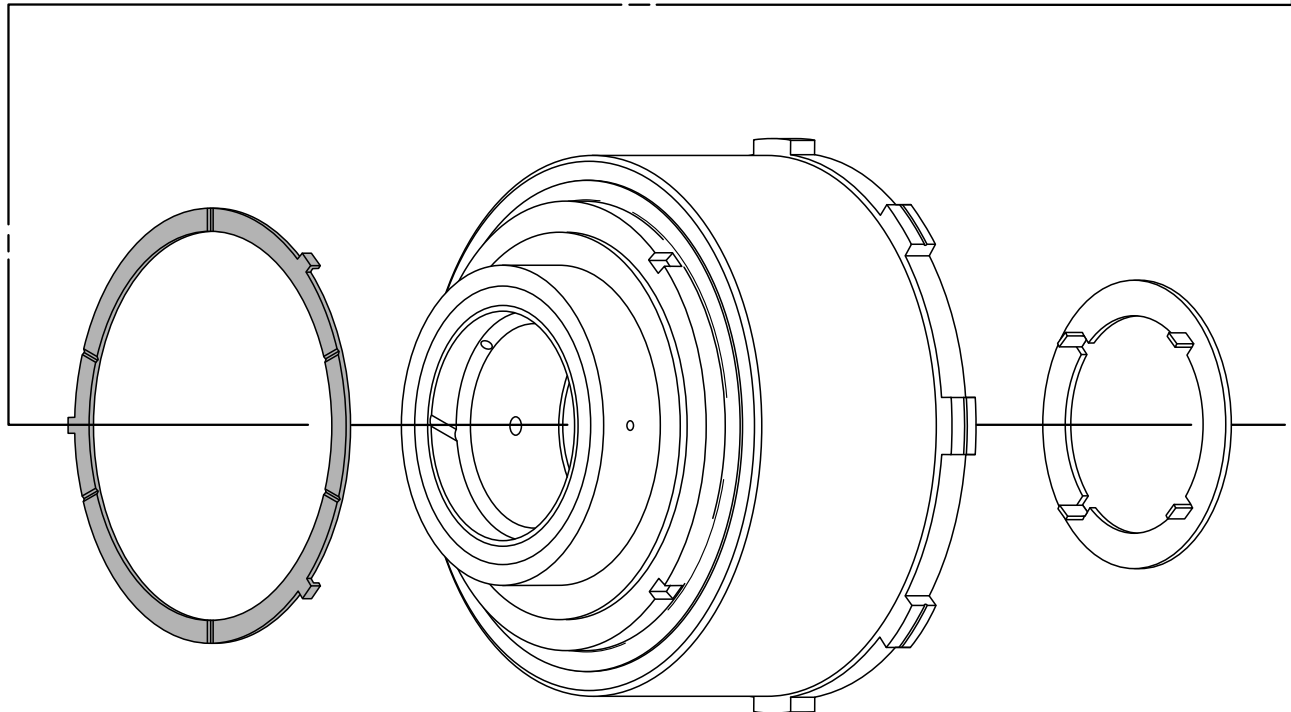
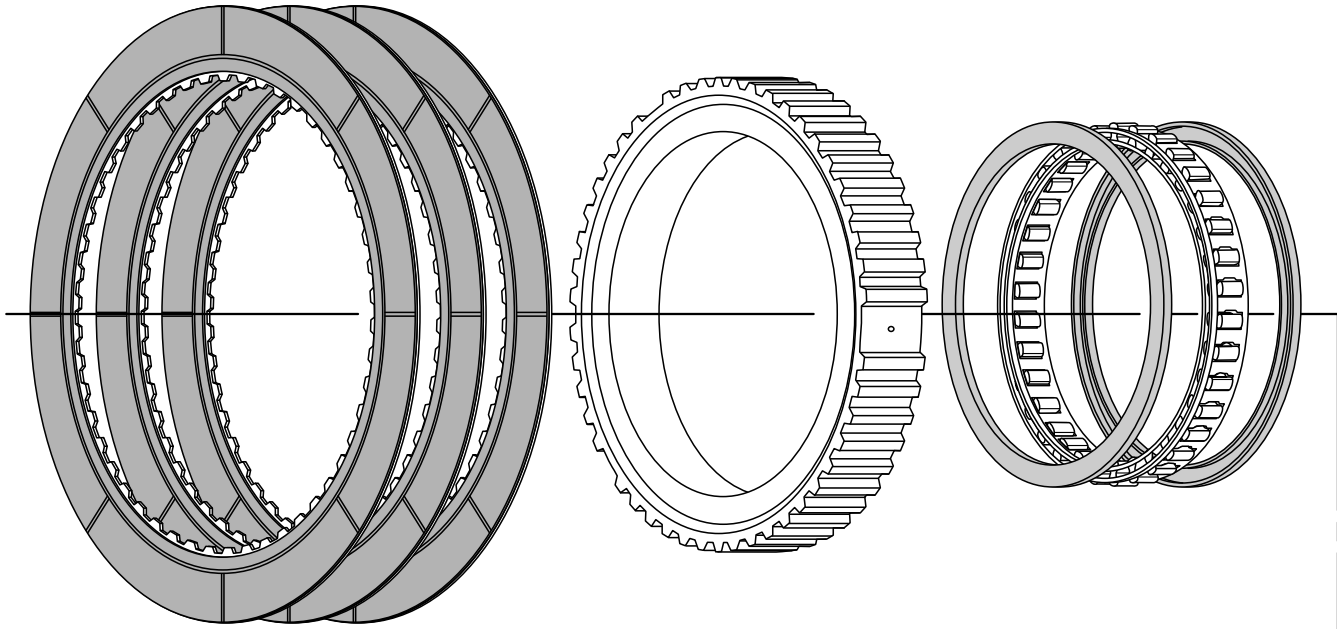


Figure 93

PARTS NEEDED TO REPLACE INTERMEDIATE DIODE

Intermediate Friction Plates
Part Number 1C3Z-7B164-BA
(Or Raybestos Plates OK)
(3 Required)

Intermediate Sprag Assembly
Part Number E9TZ-7A089-B



Outer Race To Drum Thrust Washer
Part Number E9TZ-7G401-A

Direct Clutch Housing
Part No. YC3Z-7D044-BA (No Washer)
Part No. F81Z-7D044-BA (With Washer)

4 Tab Thrust Washer
Part Number E9TZ-7C096-A



**FORD E4OD
PREMATURE OVERDRIVE CLUTCH FAILURE
(INCREASED CAPACITY)**

COMPLAINT: Some vehicles equipped with the E4OD transmission may exhibit premature failure of the overdrive clutches, especially heavier loaded vehicles.

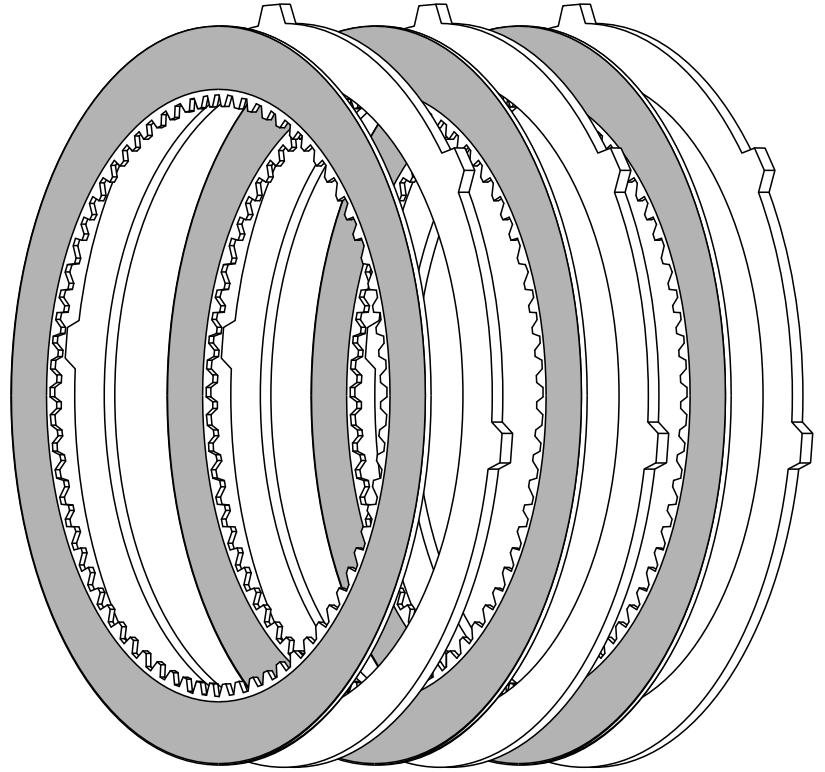
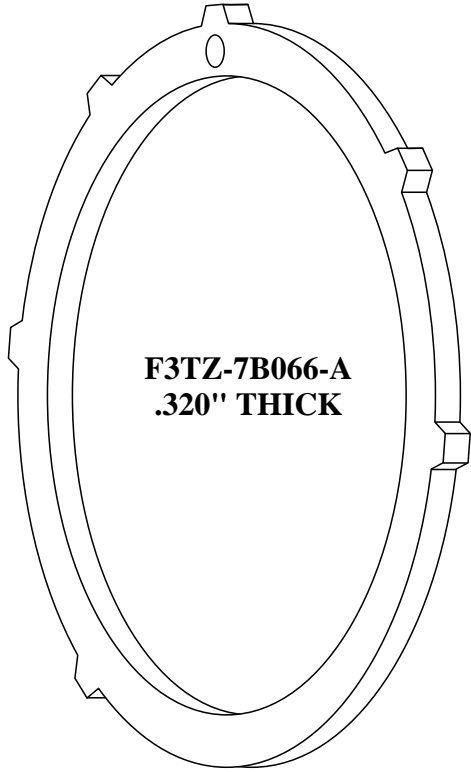
CAUSE: The cause may be, not enough clutch capacity for the overdrive clutch.

CORRECTION: Install 3 clutches in the overdrive clutch pack by purchasing a thinner, .320" thick backing plate, to replace the previous .490" thick backing plate. The 3 clutch backing plate is available under OEM part number F3TZ-7B066-A. Refer to Figure 95 for both the 2 clutch and 3 clutch stack-ups.

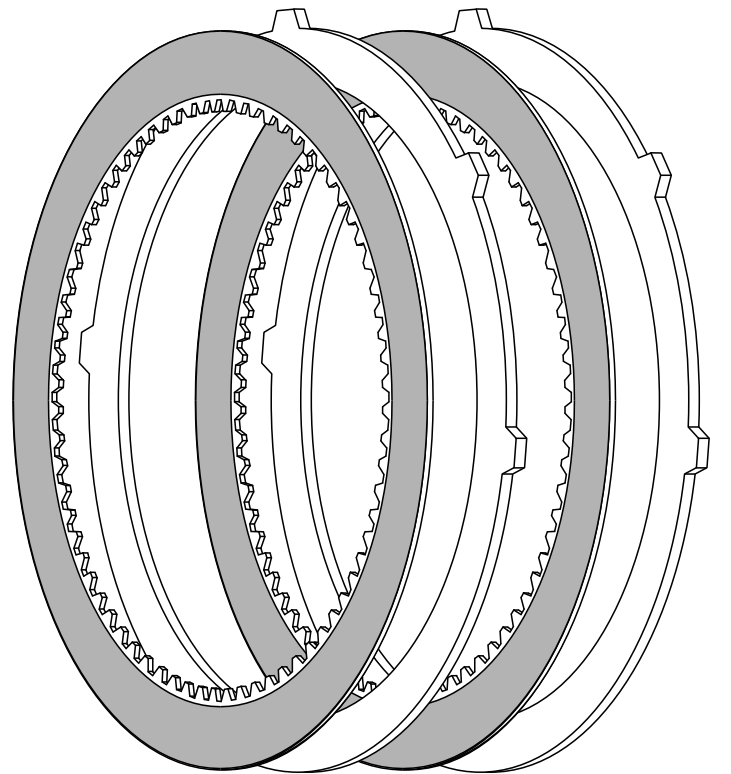
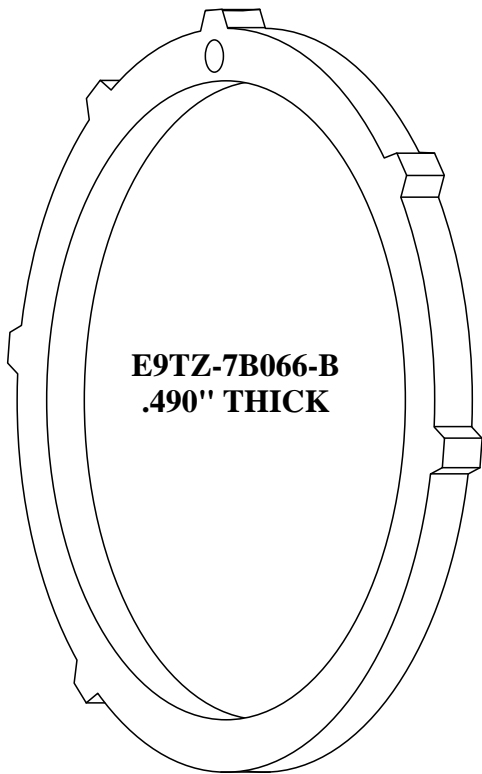
SERVICE INFORMATION:

- Overdrive Clutch Backing Plate (3 Clutch) F3TZ-7B066-A
- Overdrive Clutch Backing Plate (2 Clutch) E9TZ-7B066-B

E4OD 3 PLATE OVERDRIVE CLUTCH STACK-UP



E4OD 2 PLATE OVERDRIVE CLUTCH STACK-UP



Copyright © 2004 ATSG

Figure 95



Technical Service Information

Notes