

12H

Motor Grader



Global Version

Cat® C-9 ETA Engine

Base Power (all gears)	108 kW	145 hp
------------------------	--------	--------

Variable Horsepower Arrangement

- gears 1-3	108 kW	145 hp
-------------	--------	--------

- gears 4-8	123 kW	165 hp
-------------	--------	--------

Variable Horsepower Plus Arrangement

- gears 1-3	108 kW	145 hp
-------------	--------	--------

- gears 4-6	123 kW	165 hp
-------------	--------	--------

- gears 7-8	138 kW	185 hp
-------------	--------	--------

Weights

Gross Vehicle Weight-base	14 200 kg	31,320 lb
---------------------------	-----------	-----------

front axle	3784 kg	8346 lb
------------	---------	---------

rear axle	10 416 kg	22,974 lb
-----------	-----------	-----------

Moldboard

Blade Width	3658 mm	12 ft
-------------	---------	-------

12H Motor Grader

The 12H blends productivity and durability to give you the best return on your investment.

Engine

- ✓ The Cat C-9 engine is designed and rated to handle the tough loads. The Variable Horsepower option maximizes response, power, and efficiency, while the direct drive, power shift transmission optimizes blade control and versatility. **pg. 4**

Power Train

The power shift transmission takes full advantage of the powerful C-9 engine. Variable Horsepower uses specific torque curves for each gear range for optimum performance. Dual air system and multi-disc oil brakes assure reliable braking control. **pg. 5**

Hydraulics

The load-sensing hydraulic system lowers power consumption and system heat. The advanced PPPC control valves provide low lever effort, balanced flow and consistent cylinder speeds for outstanding blade control. Blade float is incorporated into the blade lift valves. **pg. 6**

Operator's Station

- ✓ Low effort blade controls, electronic throttle control, EMS III monitoring system, and improved ventilation provide world-class operator control and comfort. Excellent front and rear visibility can increase operator confidence and productivity. **pg. 10**

Environmentally Responsible Design

- ✓ New engine arrangements and operator station designs reduce emissions to meet current and anticipated regulations for interior and exterior sound levels, emissions, exhaust. **pg. 12**

Matched and balanced components.

The Cat[®] C-9 engine, direct-drive power shift transmission and load-sensing hydraulics are designed to work together to deliver top productivity in all applications.

Superior visibility, control layout and operating ease.

The operator is the single most important factor in maintaining high productivity throughout the work day. By offering the best operator's station in the industry, Caterpillar helps operators achieve peak performance.



Standard Equipment

Standard equipment may vary. Consult your Caterpillar dealer for details.

ELECTRICAL

- Alarm, back-up
- Alternator, 35 ampere, sealed
- Batteries, maintenance free, 750 CCA
- Electrical system, 24 volt
- Lights, stop and tail
- Motor, starting
- Product Link connection

OPERATOR ENVIRONMENT

- Accelerator
- Ashtray and lighter
- Coat hook
- Control console, adjustable
- Cup holder
- EMS III operator warning system
- Panel gauges inside cab
 - fuel
 - articulation
 - engine coolant temp
 - system voltage
 - air brake pressure
- Hydraulic controls, load sensing
 - right/left blade lift with float position
 - blade sideshift and tip
 - circle drive
 - centershift
 - front wheel lean
 - articulation
- Meter, hour, digital
- Mirror, inside rearview, wide angle
- Mounting bracket, general purpose
- Power steering, hydraulic
- ROPS cab, sound suppressed, low profile
- Seat, cloth, static
- Seat belt, retractable 76 mm (3 in)
- Steering wheel, tilt, adjustable
- Storage area for cooler/lunchbox
- Sunscreen, front windshield
- Throttle control, electronic
- Washer/wipers, (3) front windshields
- Windows, fixed lower front

POWERTRAIN

- Air cleaner
 - dry type radial seal
 - service indicator
 - automatic dust ejector
- Air-to-air aftercooler (ATAAC)
- Brakes - oil disc, four-wheel air actuated
- Demand fan
- Differential, lock-unlock
- Engine, C-9 ETA diesel
 - automatic derate
 - automatic idle control
- Fuel tank, sediment drain
- Fuel-water separator
- Lube for life pump drive shaft
- Muffler, under hood
- Parking brake - multi-disc, sealed and oil cooled
- Pre-screener
- Priming pump, fuel
- Serpentine belt, automatic tensioner
- Tandem drive
- Transmission
 - 8 forward/6 reverse speeds
 - power shift
 - direct drive
 - electronic shift control
 - overspeed protection

OTHER STANDARD EQUIPMENT

- Antifreeze -35°C (-30°F)
- Bumper, rear, integrated, with hitch
- Clutch, circle drive slip
- Cutting edges
 - 152 mm × 16 mm (6 in × 5/8 in)
 - curved DH-2 steel
 - 16 mm (5/8 in) mounting bolts
- Doors, engine compartment, locking
- Drawbar
 - 6 shoe
 - replaceable wear strips
- Endbits - 16 mm (5/8 in) DH-2 steel, mounting bolts
- Engine shutdown, ground level
- Frame, articulated with safety lock
- Fuel tank, 100 gallon (378 L)
- Fueling, ground level
- Horn, air
- Moldboard
 - 3658 mm × 610 mm × 22 mm (12 ft × 24 in × 7/8 in)
 - hydraulic sideshift and tip
- Radiator cleanout access
- S•O•SSM ports: engine, hydraulic, transmission, coolant, fuel
- Tool box

TIRES, RIMS, AND WHEELS

- Partial allowance: 13.00-24 10PR on 9" single piece rims

Dimensions

All dimensions are approximate.

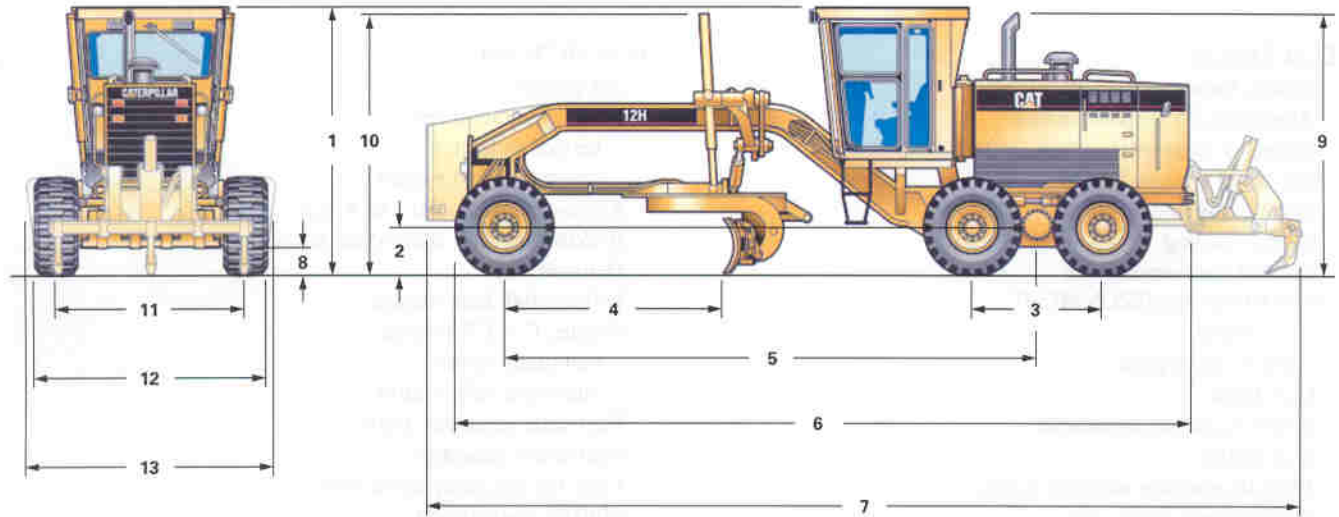

1	Height - low profile cab	3107 mm	122 in
	- high profile cab	3332 mm	131 in
	- no cab	3090 mm	122 in
2	Height to axle	594 mm	23.4 in
3	Length - between tandem axles	1523 mm	59.9 in
4	Length - front axle to moldboard	2565 mm	101 in
5	Length - front axle to mid tandem	6086 mm	239.6 in
6	Length - front tire to end of rear frame	8571 mm	337.4 in

7	Length - counterweight to ripper	10 012 mm	394.2 in
8	Ground clearance at trans. case	341.5 mm	13.4 in
9	Height to exhaust stack	3090 mm	122 in
10	Height to top of cylinders	3030 mm	119 in
11	Width - tire centerlines	2077 mm	81.8 in
12	Width - outside rear tires	2422 mm	95.3 in
13	Width - outside front tires	2440 mm	96 in

Blade Range

Circle centershift - right	728 mm	28.7 in
- left	695 mm	27.4 in
Moldboard sideshift - right	660 mm	26 in
- left	524 mm	20.6 in
Maximum blade position angle	90°	
Blade tip range (forward)	40°	
(backward)	5°	
Maximum shoulder reach outside of tires		
- right	1809 mm	71.2 in
- left	1859 mm	73.6 in
Maximum lift above ground	480 mm	18.9 in
Maximum depth of cut	735 mm	28.9 in

Ripper

Ripping depth, maximum	462 mm	18.2 in
Ripper shank holders	5	
Ripper shank holder spacing	533 mm	21 in
Penetration force	8047 kg	17,740 lb
Pryout force	9281 kg	20,460 lb
Machine length increase, beam raised	970 mm	38.2 in

Scarifier

Front, V-Type: Working width	1184 mm	46.6 in
Scarifying depth, maximum	292 mm	11.5 in
Scarifier shank holders	11	
Scarifier shank holder spacing	116 mm	4.6 in
Front, straight: Working width	1800 mm	71 in
Scarifying depth, maximum	317 mm	12.5 in
Scarifier shank holders	17	
Scarifier shank holder spacing	111 mm	4.38 in
Rear: Working width	2300 mm	91 in
Ripping depth, maximum	411 mm	16.2 in
Scarifier shank holders	9	
Scarifier shank holder spacing	267 mm	10.5 in

Weights

Gross Vehicle Weight - max	20 783 kg	45,818 lb
Front axles	6234 kg	13,744 lb
Rear axles	14 549 kg	32,074 lb
Gross Vehicle Weight - base	14 200 kg	31,320 lb
Front axles	3784 kg	8,346 lb
Rear axles	10 416 kg	22,974 lb

- Base operating weight calculated on standard machine configuration with 13.00-24 10PR (G-2) tires, full fuel tank, coolant, lubricants and operator.

Cab

- ROPS (Rollover Protective Structure) meets the following criteria: SAE J1040 MAY 94, ISO 3471: 1986, ISO 3471:1994
- FOPS (Falling Object Protective Structure) meets the following criteria: ISO 3449:1984, ISO 3449:1992 Level II

Hydraulic System

Circuit type	Closed center load sense	
Pump type	Variable piston	
Pump output	196 L/min	51.9 gal/min
Maximum system pressure	24 150 kPa	3,500 psi
Standby Pressure	3100 kPa	450 psi

- Pump output measured @ 1850 RPM

Operating Specifications

Top Speed - Fwd.	44 kph	27.4 mph
- Rev.	34.7 kph	21.6 mph
Turning radius (outside front tires)	7.4 m	24.25 ft
Steering range - left/right	50°	
Articulation angle - left/right	20°	
Fwd. 1st	3.8 kph	2.3 mph
2nd	5.1 kph	3.2 mph
3rd	7.4 kph	4.6 mph
4th	10.3 kph	6.4 mph
5th	16.2 kph	10 mph
6th	22 kph	13.7 mph
7th	30.3 kph	18.8 mph
8th	44 kph	27.4 mph
Rev. 1st	3 kph	1.8 mph
2nd	5.6 kph	3.5 mph
3rd	8.1 kph	5 mph
4th	12.8 kph	7.9 mph
5th	23.9 kph	14.8 mph
6th	34.7 kph	21.6 mph

Service Refill

Fuel Capacity	378 L	100 gal
Cooling system	44 L	11.6 gal
Hydraulic system - total	74 L	19.5 gal
- tank	38 L	9.9 gal
Engine Oil	24 L	6.3 gal
Differential/Final Drives	47 L	12.2 gal
Tandem housing (each)	64 L	16.9 gal
Front wheel spindle bearing housing	0.5 L	0.13 gal
Circle drive housing	7 L	1.8 gal

Frame

Circle - diameter	1530 mm	60.2 in
- blade beam thickness	30 mm	1.2 in
Drawbar - height	127 mm	5 in
- thickness	76 mm	3 in
Front-top/bottom plate - width	305 mm	12 in
- thickness	25 mm	1 in
Front-side plates - width	242 mm	9.5 in
- thickness	12 mm	0.5 in
Front-linear weights - min	165 kg/m	112 lb/ft
- max	213 kg/m	144 lb/ft
Front-section modulus - min	2083 cm ³	127 in ³
- max	4785 cm ³	291 in ³
Front axle - ground clearance	608 mm	23.75 in
- front wheel lean	18°	
- oscillation angle	32°	

Tandems

Height	506 mm	19.9 in
Width	201 mm	7.9 in
Sidewall thickness - inner	16 mm	0.63 in
- outer	18 mm	0.71 in
Drive chain pitch	51 mm	2 in
Wheel axle spacing	1522 mm	60 in
Tandem oscillation - forward	15°	
- reverse	25°	

Moldboard

Blade Width	3658 mm	12 ft
Moldboard Height	610 mm	24 in
Thickness	22 mm	0.87 in
Arc radius	413 mm	16.25 in
Throat clearance	120 mm	4.7 in
Cutting edge - width	152 mm	6 in
- thickness	16 mm	0.63 in
End Bit - width	152 mm	6 in
- thickness	16 mm	0.63 in
Blade Pull - max GVW	13 094 kg	28,867 lb
- base GVW	9379 kg	20,677 lb
Down Pressure - max GVW	10 799 kg	23,800 lb
- base GVW	6555 kg	14,447 lb

- Blade Pull calculated at 0.9 traction coefficient, which is equal to ideal no-slip conditions, and Gross Vehicle Weight (GVW).

Engine

Engine Model	Cat C-9 ETA VHP	
Base Power (all gears) Net	108 kW	145 hp
VHP - gears 1-3 Net	108 kW	145 hp
- gears 4-8 Net	123 kW	165 hp
VHP Plus - gears 1-3 Net	108 kW	145 hp
- gears 4-6 Net	123 kW	165 hp
- gears 7-8 Net	138 kW	185 hp
Base Power (all gears) Gross	116 kW	156 hp
VHP - gears 1-3 Gross	116 kW	156 hp
- gears 4-8 Gross	131 kW	176 hp
VHP Plus - gears 1-3 Gross	116 kW	156 hp
- gears 4-6 Gross	131 kW	176 hp
- gears 7-8 Gross	146 kW	196 hp
Displacement	8.8 L	537 in ³
Bore	112 mm	4.4 in
Stroke	149 mm	5.9 in
Torque rise	50%	
Max torque @ 1000 rpm	988 N•m	728 lb-ft

Speed @ rated power	2000 RPM	
Number of cylinders	6	
Derating altitude	3048 m	10,000 ft
Std - Fan speed - max	1210 RPM	
- min	500 RPM	
Std - Ambient Capability	47° C	117° F
Hi Ambient - Fan speed - max	1350 RPM	
- min	500 RPM	
Hi - Ambient Capability	50° C	122° F

- Net power is tested per ISO 9249, SAE J1349, and EEC 80/1269 standards in effect at the time of manufacture.
- VHP and VHP Plus are optional arrangements.
- Net power advertised is the power available at rated speed of 2000 rpm, measured at the flywheel when engine is equipped with fan, air cleaner, muffler and alternator.
- No derating required up to 3048 m (10,000 ft) altitude. Deration rate of 1.5% per 304.8 m (1000 feet) above 3048 m (10,000 feet).

Base
VHP
VHP Plus

Gears 1 - 8
Gears 1 - 3
Gears 1 - 3

Gears 4 - 8
Gears 4 - 6

Gears 7 - 8

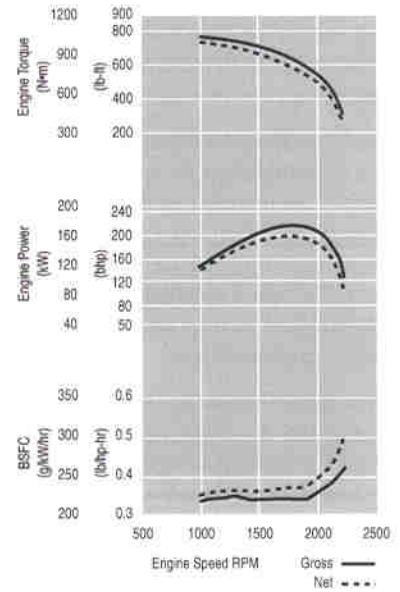
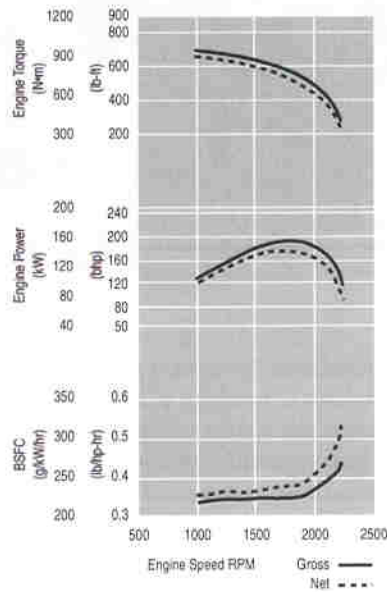
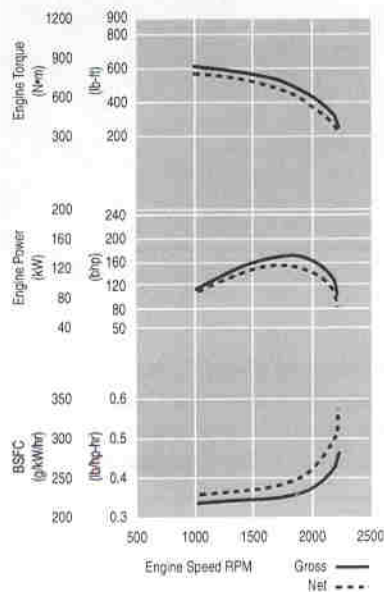

Power Train

Forward/Reverse Gears	8 fwd/6 rev	
Transmission	Direct drive, power shift	
Brakes - Service	Air actuated multiple oil disc	
- Service, surface area	23 948 cm ²	3,712 in ²
- Parking	Air-actuated, multiple oil-disc	
- Secondary	Dual circuit	

- Brakes meet the following standards: SAE J/ISO3450 JAN 98.

Customer Support

Cat dealer services help you operate longer with lower costs.

Product Support. You will find nearly all parts at our dealer parts counter. Cat dealers use a world-wide computer network to find in-stock parts to minimize machine down time. Save money with genuine Cat Reman parts. You receive the same warranty and reliability as new products at substantial cost savings.

Machine Selection. Make detailed comparisons of the machines under consideration before purchase. Cat dealers can estimate component life, preventive maintenance cost, and the true cost of lost production.

Purchase. Look past initial price. Consider the financing options available as well as day-to-day operating costs. Look at dealer services that can be included in the cost of the machine to yield lower equipment owning and operating costs over the long run.

Customer Support Agreements. Cat dealers offer a variety of product support agreements, and work with customers to develop a plan that best meets specific needs. These plans can cover the entire machine, including attachments, to help protect the customer's investment.

Operation. Improving operating techniques can boost your profits. Your Cat dealer has videotapes, literature and other ideas to help you increase productivity, and Caterpillar offers certified operator training classes to help maximize the return on your machine investment.



Maintenance Services. Talk to your dealer about the range of available maintenance services. Repair option programs guarantee the cost of repairs up front. Diagnostic programs such as S•O•SSM Analysis and Coolant Sampling and Technical Analysis help avoid unscheduled repairs.

Replacement. Repair, rebuild or replace? Your Cat dealer can help you evaluate the cost involved so you can make the right choice.

Engine

Engine Model	Cat C-9 ETA VHP	
Base Power (all gears) Net	108 kW	145 hp
VHP - gears 1-3 Net	108 kW	145 hp
- gears 4-8 Net	123 kW	165 hp
VHP Plus - gears 1-3 Net	108 kW	145 hp
- gears 4-6 Net	123 kW	165 hp
- gears 7-8 Net	138 kW	185 hp
Base Power (all gears) Gross	116 kW	156 hp
VHP - gears 1-3 Gross	116 kW	156 hp
- gears 4-8 Gross	131 kW	176 hp
VHP Plus - gears 1-3 Gross	116 kW	156 hp
- gears 4-6 Gross	131 kW	176 hp
- gears 7-8 Gross	146 kW	196 hp
Displacement	8.8 L	537 in ³
Bore	112 mm	4.4 in
Stroke	149 mm	5.9 in
Torque rise	50%	
Max torque @ 1000 rpm	988 N•m	728 lb-ft

Speed @ rated power	2000 RPM	
Number of cylinders	6	
Derating altitude	3048 m	10,000 ft
Std - Fan speed - max	1210 RPM	
- min	500 RPM	
Std - Ambient Capability	47° C	117° F
Hi Ambient - Fan speed - max	1350 RPM	
- min	500 RPM	
Hi - Ambient Capability	50° C	122° F

- Net power is tested per ISO 9249, SAE J1349, and EEC 80/1269 standards in effect at the time of manufacture.
- VHP and VHP Plus are optional arrangements.
- Net power advertised is the power available at rated speed of 2000 rpm, measured at the flywheel when engine is equipped with fan, air cleaner, muffler and alternator.
- No derating required up to 3048 m (10,000 ft) altitude. Deration rate of 1.5% per 304.8 m (1000 feet) above 3048 m (10,000 feet).

Base Gears 1 - 8
VHP Gears 1 - 3
VHP Plus Gears 1 - 3

Gears 4 - 8
Gears 4 - 6

Gears 7 - 8

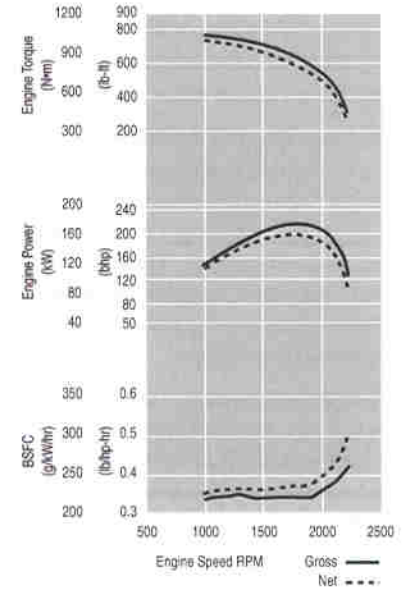
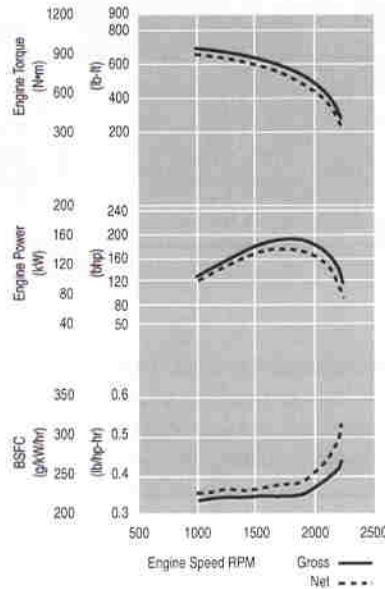
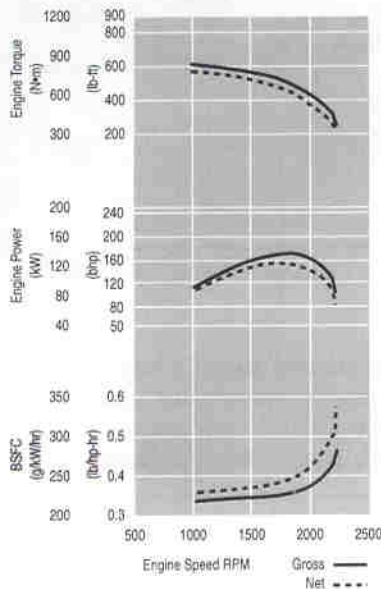

Power Train

Forward/Reverse Gears	8 fwd/6 rev	
Transmission	Direct drive, power shift	
Brakes - Service	Air actuated multiple oil disc	
- Service, surface area	23 948 cm ²	3,712 in ²
- Parking	Air-actuated, multiple oil-disc	
- Secondary	Dual circuit	

- Brakes meet the following standards: SAE J/ISO3450 JAN 98.

Customer Support

Cat dealer services help you operate longer with lower costs.

Product Support. You will find nearly all parts at our dealer parts counter. Cat dealers use a world-wide computer network to find in-stock parts to minimize machine down time. Save money with genuine Cat Reman parts. You receive the same warranty and reliability as new products at substantial cost savings.

Machine Selection. Make detailed comparisons of the machines under consideration before purchase. Cat dealers can estimate component life, preventive maintenance cost, and the true cost of lost production.

Purchase. Look past initial price. Consider the financing options available as well as day-to-day operating costs. Look at dealer services that can be included in the cost of the machine to yield lower equipment owning and operating costs over the long run.

Customer Support Agreements. Cat dealers offer a variety of product support agreements, and work with customers to develop a plan that best meets specific needs. These plans can cover the entire machine, including attachments, to help protect the customer's investment.

Operation. Improving operating techniques can boost your profits. Your Cat dealer has videotapes, literature and other ideas to help you increase productivity, and Caterpillar offers certified operator training classes to help maximize the return on your machine investment.



Maintenance Services. Talk to your dealer about the range of available maintenance services. Repair option programs guarantee the cost of repairs up front. Diagnostic programs such as S•O•SSM Analysis and Coolant Sampling and Technical Analysis help avoid unscheduled repairs.

Replacement. Repair, rebuild or replace? Your Cat dealer can help you evaluate the cost involved so you can make the right choice.

Environmentally Responsible Design

Caterpillar builds machines that help you create a better world.



Quiet Cab. The resiliently mounted engine and transmission reduce interior engine noise and vibration. With the sound suppression group, interior sound levels are 75 dB(A), per ISO 6394. Lower interior noise levels improve operator working conditions.

Quiet Machine. Exterior sound levels are 109 dB(A) per ISO 6395. The sound suppression group lowers exterior sound levels below 108 dB(A), complying with the EU 2000/14/EC sound limit of 109 dB(A). This quiet operation lets the 12H work with minimal disturbance to the surroundings.

Low Emissions. The 12H Motor Grader is even more environmentally friendly than its predecessors with reductions in NOx, hydrocarbon, and particulate emissions. It meets or exceeds all U.S. EPA Tier 2 and EU Stage II emissions control standards worldwide.

Fuel Efficient. Caterpillar state-of-the-art electronically controlled, unit injection fuel system has high injection pressure for complete fuel combustion, increased fuel efficiency and reduced emissions.

Dry Machine. Lubricant fill points and filters are designed to minimize spillage. O-ring face seals, Cat XT hose and Cat hydraulic cylinders protect against leaks.

Extended Oil Change Interval. Operate a full 500 hours between engine oil and filter changes, 4000 hours between hydraulic oil changes, and 6000 hours between engine coolant changes. This reduces downtime and operating expense.

Ecology Drains. Make regular maintenance easier and help prevent spills when changing fluids.

Ozone Protection. To help protect the earth's ozone layer, air-conditioning units use a refrigerant free of chlorofluorocarbons (CFCs).

Comfort and Convenience. Comfort and convenience are designed into every feature of the operator's station.

Autoshift Transmission. Improves ease of operation and maximizes productivity by automatically shifting the transmission at optimal shift points.

Optimized Inching Modulation. The new Electronic Clutch Pressure Control (ECPC) optimizes inching modulation and smoothes shifting. It also eliminates cable control, improving reliability and enhances cold oil characteristics.

Electronic Throttle Control. ETC provides easier, more precise, more consistent throttle operation. Two modes on a single switch offer flexibility for varying applications and operator preference. Like cruise control, ETC improves fuel efficiency.

Electronic Monitoring System. Powerful monitoring and diagnostic capabilities allow more efficient and safer machine operation. The Cat EMS III keeps operators better informed of machine status with:

- Continuous tracking of all critical machine parameters on a dash display
- Warnings/alerts for abnormal conditions
- Retrieval or adjustment of over 200 electronic system parameters using the powerful ET service tool

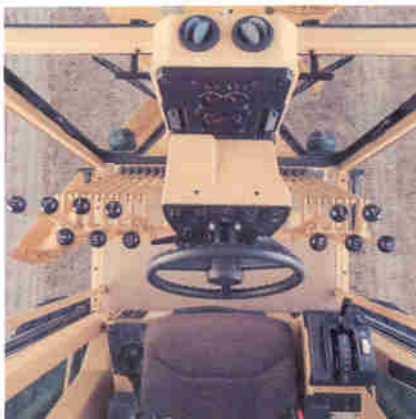

Controls On Steering Console. Controls and switches are located on the steering console, shift console and right cab post, all within easy reach. Gauges are located inside the cab, directly in front of the operator.

Backlit Controls. Rocker switches and transmission shifter are backlit for nighttime operation.

Optional Air Conditioner/Heater. The optional heater and air conditioner arrangements help create a comfortable work environment. The high-capacity systems dehumidify air and pressurize the cab, which circulates fresh air and seals out dust. Multiple additional vents evenly distribute air throughout the cab for clear windows and operator comfort.

Suspension Seat. Optional contour series suspension seat features fold-up armrests and a retractable seat belt. The seat can easily adjust for optimal support and comfort. Seat controls are located within easy reach and in plain view.

Fresh Air Filters. Located above each cab door for quick replacement.

Optional 12V Power Port. Available for use with computers, cellular phones or other electronic equipment.

Exceptional Visibility. Operator's console was redesigned, and large side windows allow a clear view of the moldboard heel and tandem tires. The 12H has a wide rear window and tapered engine hood. The air dryer and air leaner were moved, and the precleaner and muffler were aligned. Operators can work more confidently and efficiently.

Operator's Station

The 12H includes innovative changes to improve operator efficiency and, in turn, greater machine productivity.

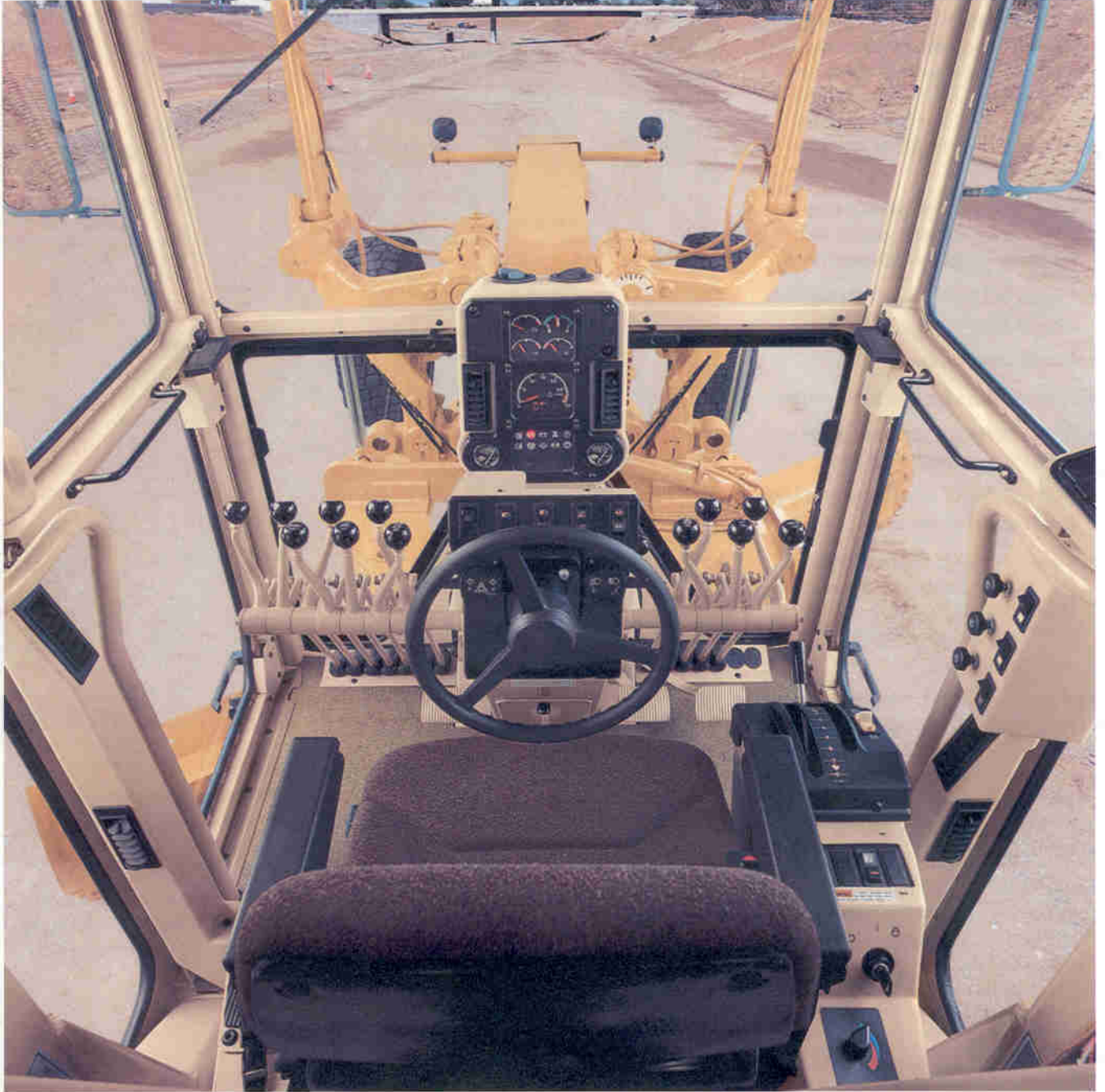

Serviceability

Re-engineered inspection and service points save time and expense.

Service Center. A 'Service Center' on the left-hand side provides easy, centralized access to most check and maintenance points. Routine inspection and service are faster and easier, for better machine availability and lower operating costs.

- Large hinged doors provide easy access to the adjacent engine and maintenance service compartments.
- Engine and hydraulic oil checkpoints, coolant gauges, and air filters
- Tandem oil checkpoint
- Spin-on filters for oils, fuel, coolant
- Remote lubrication points, purge valves and ecology drain lines
- Fuse panel with new automotive style fuses located inside cab
- Sample ports for engine, hydraulic, transmission fluids, coolant and fuel, encourages preventive maintenance and diagnostics like the S•O•SSM Analysis program.

Fuel Tank. The 378 L (100 gal) ground level fuel tank allows longer work shifts and reduces refueling times. An easily accessible fuel tank sediment drain enables the operator to remove sediment accumulation, reducing the risk of fuel system damage.

Extended Oil Change Interval. Operate a full 500 hours between engine oil and filter changes, 4000 hours between hydraulic oil changes, and 6000 hours between engine coolant changes. This reduces downtime and operating expense.



Cat XT Hose. Caterpillar XT hose technology allows high pressures for maximum power and reduced downtime, while excellent routing minimizes exposure to damage.

O-Ring Face Seals. Cat O-ring face seals assure rock-solid connections that maintain pressure and reduce oil leaks. Intelligent hose routing minimizes exposure to damage, increasing hose life and enhancing reliability.

Radiator Cleanout Access. Radiator clean-out access gives the operator the ability to clear away debris and other materials that build up around the radiator. This ensures that the radiator functions properly keeping the engine cool and increasing component life.

Structures

The 12H frame is designed and built to exceed the expectations of the customer.

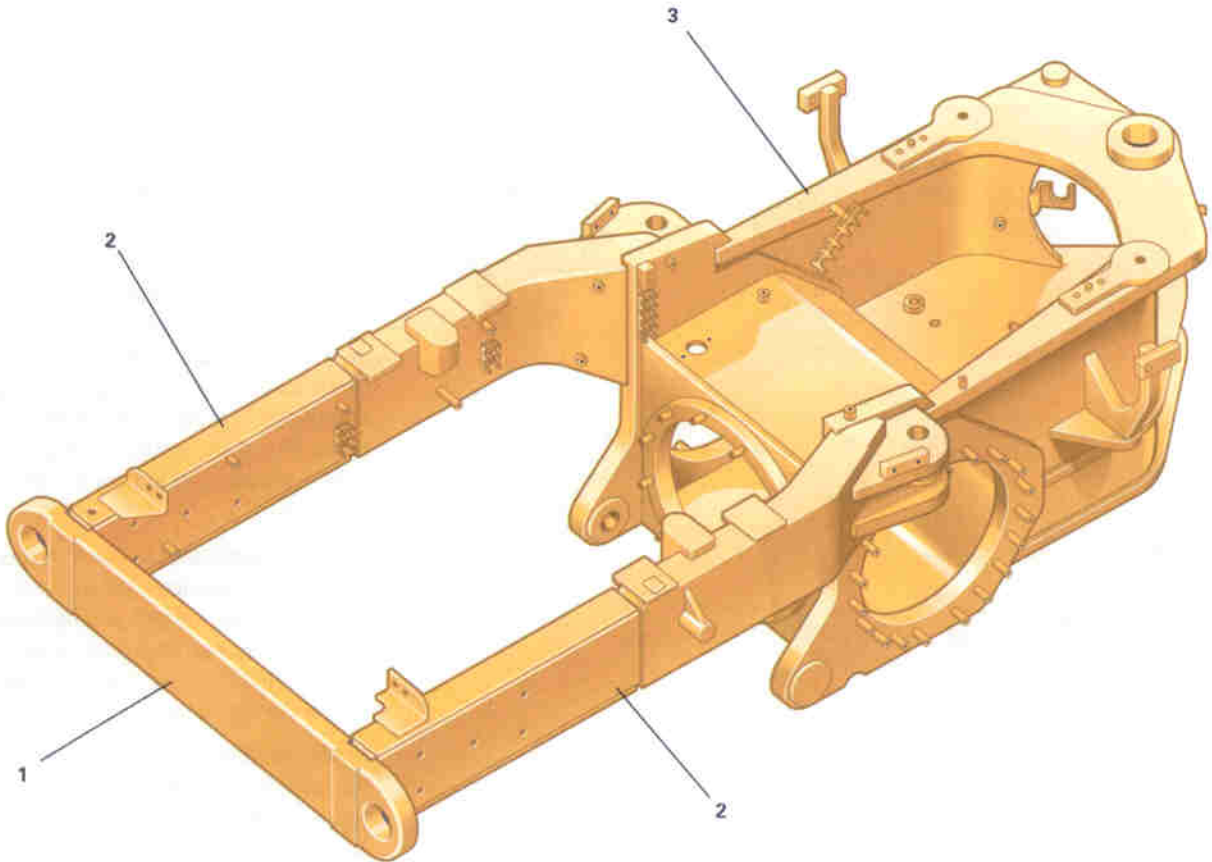

1 Integrated bumper; 2 Box-sectioned channels; 3 Fully welded differential

Integrated Bumper. The integrated bumper ties the rear frame together into a cohesive unit to provide a solid platform for the C-9 power train. This is especially important in ripping and snow removal applications where graders are equipped with snow wing attachments.

Rear Frame. Rear frame has two box-sectioned channels integral with fully welded differential case for a solid working platform.

Front Frame. Continuous top and bottom plate construction provides consistency and strength. The flanged box section design removes welds from high stress areas, improving reliability and durability, and increasing resale values for the customer.

Drawbar, Circle, Moldboard

Every component is designed for maximum productivity and durability.

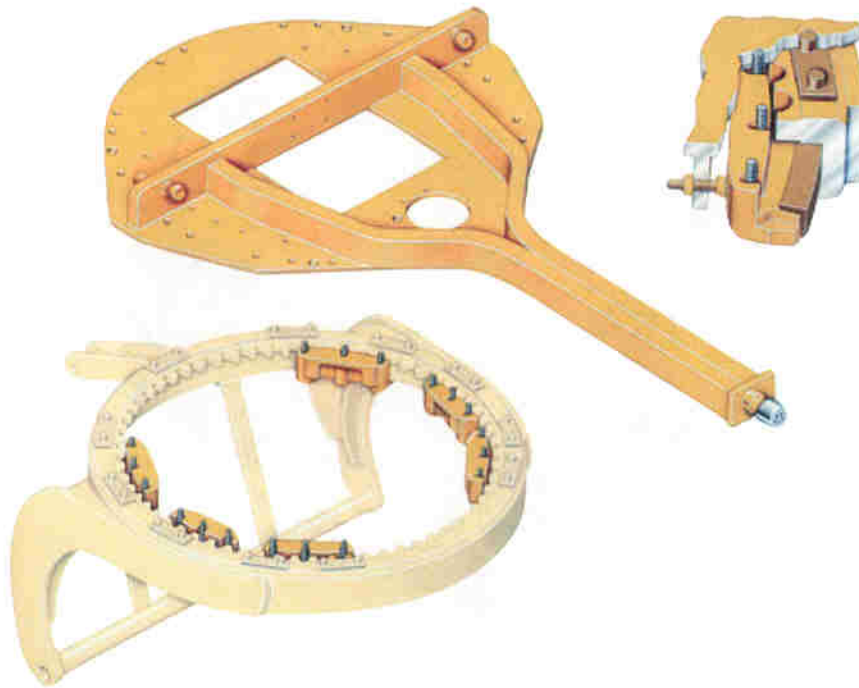

Blade. Heat treated moldboard rails, through-hardened, curved DH-2™ steel cutting edge and end bits, and replaceable metallic wear inserts assure a long, reliable service life. Three sideshift mounting locations for the optional moldboard add flexibility.

Blade Positioning. The blade linkage design provides extensive moldboard positioning, most beneficial in mid-range bank sloping and in ditch cutting and cleaning.

Blade Angle. A long wheelbase allows the operator to obtain an aggressive moldboard angle. This aggressive angle permits material to roll more freely along the blade, which reduces power requirements. This is particularly helpful in handling very dry materials, cohesive soils, snow and ice.

Circle Construction. One-piece forged circle with hydraulically driven motor stands up to high stress loads. Raised wear surfaces prevent circle teeth wear against the drawbar. Sixty-four uniformly spaced teeth on the front 240° of the circle are flame cut and heat induction hardened to resist wear. And the circle, with 360° rotation, is secured to the drawbar by six vertically and horizontally adjustable shoes for maximum support.

Replaceable Wear Items. Tough, durable nylon composite wear inserts are located between the drawbar and circle, and between the support shoes and circle. This sacrificial wear system helps keep components tight for fine grading and allows easy replacement. These inserts reduce rotational friction, resulting in extended component life.

Circle Drive Slip Clutch. The standard circle drive slip clutch protects the drawbar, circle and moldboard from shock loads when the blade encounters immovable objects. It also reduces the possibility of the grader making abrupt directional changes in poor traction conditions.

Drawbar Construction. The Y-frame drawbar is constructed of two solid beams for high strength and optimum durability, as well as precise blading control. And the yoke plate completely covers the top of the circle.

Blade Lift Accumulators. Optional blade lift accumulators absorb vertical shocks encountered when the moldboard contacts immovable objects. This option is especially useful in rough grading and rocky areas.

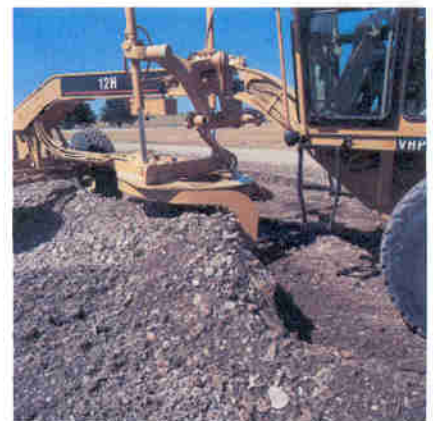

Hydraulics

Balanced hydraulics deliver consistent, precise and responsive control.

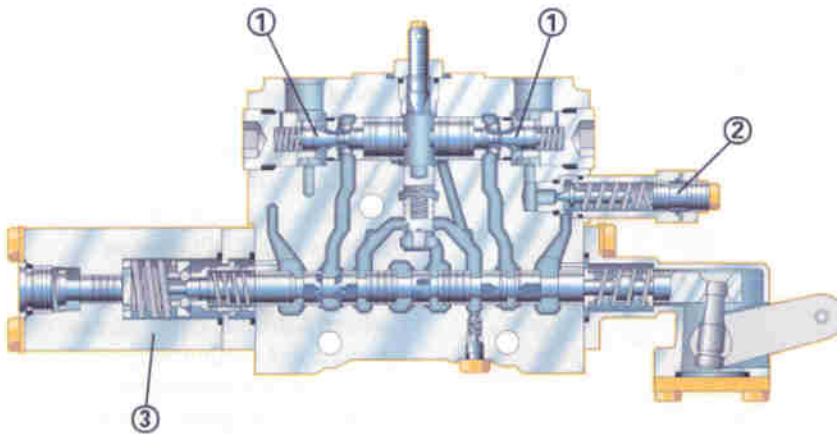

1 Lock valve, 2 Line relief valve, 3 Blade float detent

Load Sensing Hydraulics. A load sensing variable displacement pump and the advanced proportional priority pressure-compensating (PPPC, or "triple-PC") hydraulic valves provide superior implement control and enhanced machine performance and efficiency. Continuously matching hydraulic flow and pressure to power demands creates less heat and reduces power consumption.

Implement Control Valves. PPPC valves have different flow rates for the head and rod ends of the cylinder. This insures consistent extension and retraction properties for each cylinder, and improves operator 'feel' and system response. All control valves use lock valves to maintain blade settings. Line relief valves protect cylinders from excessive pressure.

Balanced Flow. Hydraulic flow is proportioned to ensure all implements operate simultaneously. If demand exceeds pump capacity, all cylinders are reduced by the same ratio. The result is improved productivity in virtually any application.

Blade Float. Blade float, incorporated into the blade lift control valves, allows the blade to move freely under its own weight. By floating both cylinders, the blade can follow the contours of the road when removing snow. Floating only one cylinder permits the toe of the blade to follow a hard surface while the operator controls the slope with the other lift cylinder.

Independent Oil Supply. Large separate hydraulic oil supply prevents cross-contamination and provides proper oil cooling, which reduces heat build-up and extends component life.

Heavy Duty XT™ Hose. Caterpillar hose technology allows high pressures for maximum power and reduced downtime, while excellent routing minimizes exposure to damage.

Optional Hydraulic Lockout. Mechanically locks all moldboard, machine, and attachment control levers during machine roading. This prevents implements from being accidentally engaged when the motor grader is traveling down the road.

Power Train

Matched Caterpillar components deliver smooth, responsive performance and reliability.

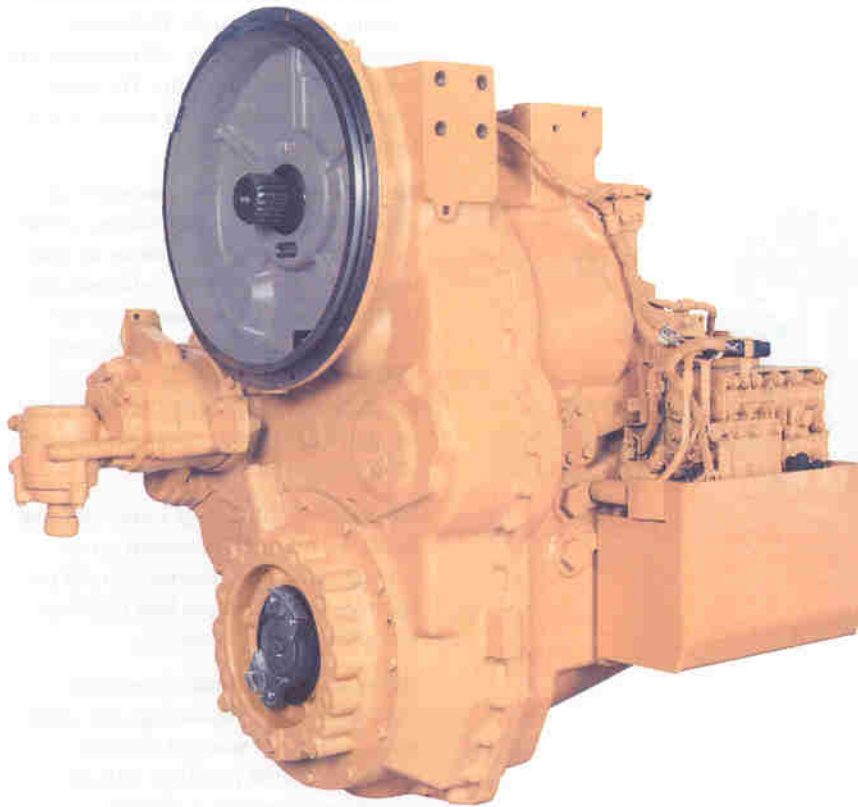

Power Shift Transmission. Designed and built specifically for Cat motor graders, the rugged transmission provides on-the-go, full-power shifting as well as inching capability.

Direct Drive. Delivers superior fuel efficiency and “feel” of blade loads, material hardness and ground speed.

Gear Selection. Eight forward and six reverse speeds offer a wide operating range for maximum flexibility. Four gears below 10.3 km/h (6.4 mph) match working speed to job conditions for maximum productivity in earthmoving jobs. Gears five, six and seven are optimal for efficient snow removal operations. Gear 8 is designed for roading.

Electronic Transmission Control.

Produces easy, smooth shifts to maintain uniform surfaces during shifting, and extends transmission life by reducing stress on transmission clutches. A single lever controls direction, gear and the parking brake.

Electronic Clutch Pressure Control.

ECPC smoothes shifts and improves inching control, which increases operator comfort and productivity. It uses input from the transmission and operator controls to modulate the directional clutches and produce consistent shifting.

Electronic Overspeed Protection.

The transmission control upshifts the transmission to relieve overspeed conditions. The transmission control will also prevent a downshift until machine speed is within the range for the requested gear. This can prevent damage and reduce component wear.

Inching Pedal. Delivers precise control of machine movements in any gear with low pedal effort and excellent modulation, critical in close-quarter work or finish grading. A new pedal design and location improves modulation and operator comfort.

Optional Autoshift. Improves ease of operation and maximizes productivity by automatically shifting the transmission at optimal shift points.

Dual Air Tanks. Supply braking capacity to each side of the machine. This system ensures secondary braking capability in the event a failure occurs in a single brake line. The dual air system also has a large reserve for stalled-engine braking.



Brakes. Caterpillar multi-disc brakes offer a large surface area for dependable, extended-life braking. The air-actuated service brakes, located in each of the four wheel spindle housings, are sealed, adjustment free, and lubricated and cooled by tandem housing oil. The parking/emergency brakes, located in the transmission on the output shaft, are spring actuated and air pressure released. When engaged, they neutralize the transmission and lock the wheels.

Engine

Caterpillar® engines deliver increased performance and lower operating costs.

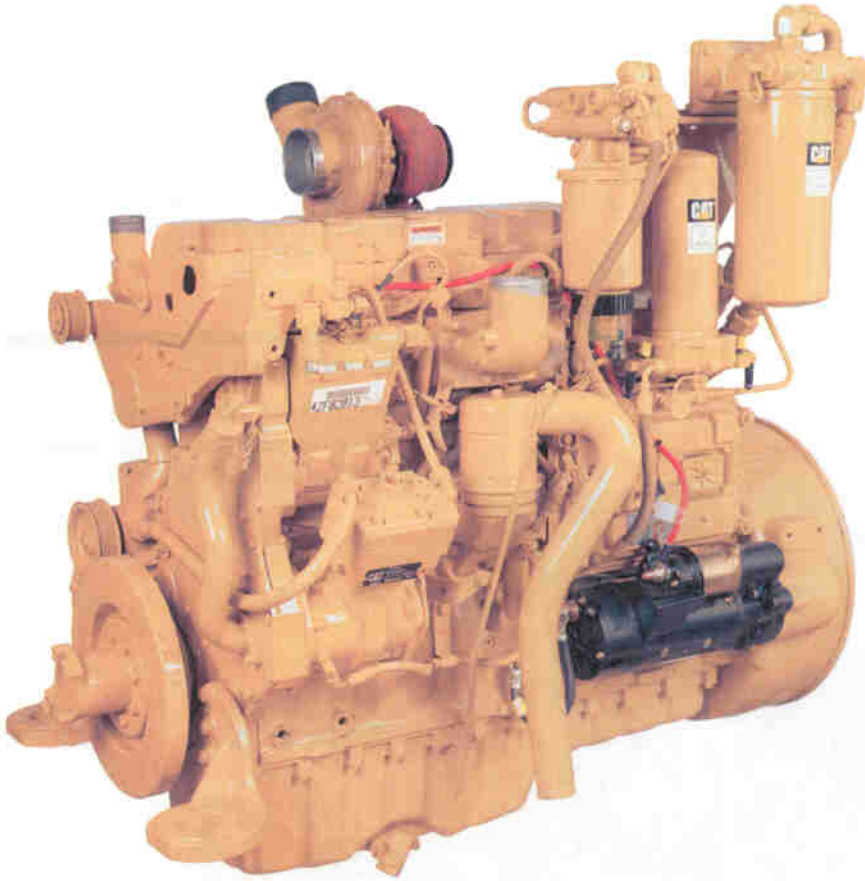

Cat C-9 ETA Engine. The innovative Cat C-9 diesel engine delivers large-engine performance from a compact engine design. This six-cylinder engine is turbocharged and air-to-air aftercooled. With high displacement and low rated speed, the C-9 provides excellent fuel economy and durability that can significantly reduce operating costs.

Variable Horsepower (VHP) and VHP Plus. Automatically increases horsepower in higher gears when the machine can use it. In applications such as snow removal, this power allows higher travel speeds and faster snow removal for more snow clearing in less time. Also, the higher rimpull in all gears maximizes performance during high-speed winging and heavy snow load applications. In lower gears where traction is limited, horsepower is limited, reducing wheel slip and conserving fuel.

- The 12H has a VHP Plus option to provide additional horsepower in forward gears 7-8.

Lugging Performance. High torque output and torque rise makes the C-9 very responsive. Its superior lugging maintains consistent grading speeds without the need to downshift.

Fuel Efficiency. Caterpillar state-of-the-art electronically controlled, unit injection fuel system uses high injection pressures for complete fuel combustion, efficient fuel use and reduced emissions. The dual-filter system reduces component wear.

Turbocharged and Air-To-Air Aftercooled. Turbocharger packs more dense air into the cylinders for more complete combustion and lower emissions, improving performance and engine efficiency. These benefits are especially useful at high altitudes. Air-to-air aftercooler reduces smoke and emissions by providing cooler inlet air for more efficient combustion. This also extends the life of the piston rings and bore.

Extended Engine Life. The large bore-stroke design and conservative power rating minimize internal stresses and increase component life. The low engine speeds reduce engine wear and sound levels.

Hydraulic Demand Fan. Automatically adjusts fan speed according to engine cooling requirements. This system reduces demands on the engine, puts more power to the ground and improves fuel efficiency.

Caterpillar Engine Oil. It is formulated to optimize engine life and performance and is strongly recommended for use in Cat diesel engines. The engine oil change interval is increased to 500 hours.

Improved Torque. Power curves customized for the 12H increase peak torque for higher ground speeds and enhanced productivity. Rimpull has been increased in all gears for greater productivity.

Emissions Compliant. The new 12H has reduced NOx, hydrocarbon, and particulate emissions. The Cat C-9 meets or exceeds all U.S. EPA Tier 2 and EU Stage II emissions control requirements.

Drawbar, Circle, Moldboard

Flexible moldboard positioning and a long wheelbase improve material handling. Rugged construction and replaceable wear parts minimize operation costs. **pg. 7**

Structures

The 12H frame is designed and built to exceed the expectations of the customer. **pg. 8**

Serviceability

- ✓ Caterpillar® re-engineered inspection and service points, grouping them into a convenient left-hand side, ground level 'service center.' Ground level fueling and extended engine and hydraulic oil change intervals help minimize downtime. **pg. 9**

Customer Support

Your Cat dealer offers a range of services that help you operate longer with lower costs. **pg. 13**



✓ *New Feature*

Optional Equipment

Optional equipment may vary. Consult your Caterpillar dealer for details.
All weights approximate.

	kg	lb
Accumulators, blade lift	71	156
Air conditioner with heater and pressurizer	49	107
Air dryer	13	29
Alternator, 75 ampere	7	15
Autoshift, transmission	2	5
Batteries, extreme duty, 1300 CCA	58	128
Batteries, heavy duty, 1100 CCA	42	93
Blade, 3658 mm × 688 mm × 25 mm (12 ft × 27 in × 1 in)	151	340
Blade, 3962 mm × 686 mm × 25 mm (13 ft × 27 in × 1 in)	208	460
Blade, 4267 mm × 610 mm × 22 mm (14 ft × 24 in × 7/8 in)	75	166
Blade, 4267 mm × 688 mm × 25 mm (14 ft × 27 in × 1 in)	261	574
Blade, front-mounted 2750 mm × 980 mm (9 ft × 39 in)	850	1874
Blade, front dozer	1180	2602
Blade, front, narrow	1100	2425
Blade, front, with foldable ends	1525	3362
Cab, ROPS, high profile, sound suppressed	77	170
Canopy, ROPS, high profile, with rear wall and window	-41	-90
Converter, 25-amp, 24-V to 12-V	5	11
Covers, louver with screen	7	15
Covers, lower rear frame	11	25
Covers, metallic, fuel tank	11	25
Cutting edges for 22 mm (7/8 in) thick blade		
203 mm × 19 mm (8 in × 3/4 in) for 3.7 m blade		
203 mm × 19 mm (8 in × 3/4 in) for 4.1 m blade		
203 mm × 16 mm (8 in × 5/8 in) for 3.7 m blade		
203 mm × 16 mm (8 in × 5/8 in) for 4.1 m blade		
Cutting edges for 25 mm (1 in) thick blade		
203 mm × 19 mm (8 in × 3/4 in) for 3.7 m blade		
203 mm × 19 mm (8 in × 3/4 in) for 4.1 m blade		
Endbits, overlay, reversible	11	24
Engine, VHP or VHP Plus	4	10
Ether starting aid	1	2
Extensions, blade 610 mm (2 ft) right and left		
for 22 mm (7/8 in) thick blade	114	250
for 25 mm (1 in) thick blade	148	325
Fan, defroster, front and rear	2	4
Graderbit system, penetration bit type	163	360
Guard, brake lines	8	18
Guard, lower platform	23	50
Guard, transmission	98	215
Hammer, with mounting	5	12
Heater, engine coolant	1	3
Heater, cab	14	30
Heater, cab, with pressurizer	18	40

	kg	lb
Hydraulic arrangements with one or more additional hydraulic valves are available for front scarifier, rear ripper-scarifier, dozer, dozer angle, snow plow and snow wing. See dealer price list.		
Hydraulic lockout	2	5
Lighting systems:		
bar mounted, directional and headlights	13	28
cab mounted, directional and headlights	9	20
cab and bar mounted, directional, headlights and work lights	22	48
cab and bar mounted, high, directional, headlights and work lights	22	48
work lights, front and rear	6	13
snow wing light, right	18	40
warning light, cab or canopy mounted	3	6
Mirrors, dual, inside mounted	-	-
Mirrors, outside mounted	8	18
Mirrors, outside mounted, heated	11	25
Mount, snow wing, frame-ready	91	200
Power port, 12-V	2	5
Precleaner, turbine-type	-	-
Push plate, front mounted	919	2025
Radio ready, entertainment		
Receptacle, starting, plug-in	2	5
Rims, tires - refer to dealer price list		
Ripper-scarifier, rear	961	2119
Ripper-scarifier/tooth, one	33	72
Rear scarifier, shanks/teeth, nine	65	144
Scarifier, front mounted, V-type	845	1862
Scarifier, front mounted, straight	903	1988
Seat, cloth-covered, contour air suspension		
Seat, vinyl-covered, contour suspension		
Snow arrangements, refer to Snow Arrangement Supplement		
Sound suppression	91	200
Speedometer/tachometer	1	2
Steering, secondary	50	111
Sunshade, rear window	3	7
Windows, lower front, opening	3	6
Windows, sliding side	4	8
Wiper and washer, rear, intermittent	7	16
Wiper and washer, front, intermittent		
European roading group which provides an additional air tank, air circuit protection valve and two position lights with integral turn signals. Dealer supplied equipment is required to meet some specific country on-road requirements	23	52