

MARIE LA

▲ WARNING

Failure to follow these safety precautions may increase your risk of injury:

- Wear a helmet, eye protection, and bright protective clothing.
- Don't ride after consuming alcohol or other drugs.
- Slow down on slippery roads, unfamiliar terrain, or when visibility is reduced.
- Read owner's manual carefully.

Part No. 99011-16D31-03A
September, 1993 (1st Ed.)
Printed in Japan

SUZUKI

OWNER'S MANUAL

This owner's manual contains important safety information. Please read it carefully.



DR250SE

IMPORTANT

WARNING/CAUTION/NOTE

Please read this manual and follow its instructions carefully. To emphasize special information, the symbol  and the words WARNING, CAUTION and NOTE have special meanings. Pay special attention to the messages highlighted by these signal words:

WARNING

Indicates a potential hazard that could result in death or injury.

CAUTION

Indicates a potential hazard that could result in motorcycle damage.

NOTE: Indicates special information to make maintenance easier or instructions clearer.

WARNINGS and CAUTIONS are arranged like this:

WARNING - or - CAUTION

The first part will describe a **POTENTIAL HAZARD** and **WHAT CAN HAPPEN** if you ignore the **WARNING** or **CAUTION**.

The second part will describe **HOW TO AVOID THE HAZARD**.

FOREWORD

Motorcycling is one of the most exhilarating sports and to ensure your riding enjoyment, you should become thoroughly familiar with the information presented in this Owner's Manual before riding the motorcycle.

The proper care and maintenance that your motorcycle requires is outlined in this manual. By following these instructions explicitly you will ensure a long trouble-free operating life for your motorcycle. Your Suzuki dealer has experienced technicians that are trained to provide your machine with the best possible service with the right tools and equipment.

All information, illustrations, photographs and specifications contained in this manual are based on the latest product information available at the time of publication. Due to improvements or other changes, there may be some discrepancies in this manual. Suzuki reserves the right to make production changes at any time, without notice and without incurring any obligation to make the same or similar changes to vehicles previously built or sold.

Suzuki Motor Corporation believes in conservation and protection of Earth's natural resources. To that end, we encourage every vehicle owner to recycle, trade in, or properly dispose of, as appropriate, used motor oil, coolant and other fluids: batteries, and tires.

SUZUKI MOTOR CORPORATION

© COPYRIGHT SUZUKI MOTOR CORPORATION 1993

TABLE OF CONTENTS

| | |
|--|----|
| THE SPORT OF MOTORCYCLING | 3 |
| FUEL AND ENGINE OIL RECOMMENDATION | 10 |
| LOCATION OF LABELS | 12 |
| LOCATION OF PARTS | 13 |
| CONTROLS, EQUIPMENT AND ADJUSTMENTS | 14 |
| KEY | 14 |
| IGNITION SWITCH | 14 |
| STEERING LOCK | 15 |
| INSTRUMENT PANEL | 15 |
| LEFT HANDLEBARS | 16 |
| RIGHT HANDLEBARS | 17 |
| FUEL TANK CAP | 18 |
| FUELCOCK | 19 |
| CARBURETOR CHOKE KNOB | 20 |
| GEARSHIFT LEVER | 20 |
| REAR BRAKE PEDAL | 21 |
| HELMET HOLDER | 21 |
| SIDE STAND | 22 |
| FRONT SUSPENSION | 23 |
| REAR SUSPENSION | 24 |
| BREAK-IN | 25 |
| INSPECTION BEFORE RIDING | 26 |
| RIDING TIPS | 27 |
| ACCESSORY USE AND MOTORCYCLE LOADING | 32 |

| | |
|--|----|
| INSPECTION AND MAINTENANCE | 35 |
| MAINTENANCE SCHEDULE | 35 |
| TOOLS | 38 |
| GENERAL LUBRICATION | 38 |
| BATTERY | 38 |
| AIR CLEANER | 39 |
| SPARK PLUG | 41 |
| ENGINE OIL | 43 |
| CARBURETOR | 46 |
| FUEL LINE | 48 |
| CLUTCH ADJUSTMENT | 48 |
| DRIVE CHAIN | 49 |
| BRAKES | 51 |
| TIRES | 55 |
| SPOKE NIPPLE TIGHTNESS | 57 |
| SIDE STAND/IGNITION INTERLOCK SYSTEM | 57 |
| SPARK ARRESTER | 58 |
| FRONT WHEEL REMOVAL | 59 |
| REAR WHEEL REMOVAL | 60 |
| LIGHT BULB REPLACEMENT | 61 |
| FUSE | 63 |
| TROUBLESHOOTING | 64 |
| STORAGE PROCEDURE | 66 |
| APPEARANCE CARE | 67 |
| CONSUMER INFORMATION | 70 |
| EMISSION CONTROL WARRANTY | 70 |
| REPORTING SAFETY DEFECTS... TAMPERING WITH NOISE CONTROL SYSTEM PROHIBITED | 70 |
| SERIAL NUMBER LOCATION | 71 |
| SPECIFICATIONS | 72 |

THE SPORT OF MOTORCYCLING

Your motorcycle and this owner's manual have been designed by people like you who enjoy motorcycling. People become motorcyclists for many reasons. For starters, street riding is fun and invigorating. But no matter why you became a motorcyclist, or how experienced you are, you will eventually face some challenging situations.

In preparing for these challenges, you will be fine-tuning your coordination, concentration, and attitude. Learning the skills and strategies associated with motorcycling is the basis for safely participating in this sport. Many motorcyclists find that as they become better riders, they also get more enjoyment from the freedom unique to motorcycling.

Please remember:

1. **Most accidents can be avoided.**

The most common type of motorcycle accident in the U.S. occurs when a car traveling towards a motorcycle turns left in front of the motorcycle. Is that because other drivers are out to get motorcyclists? No. Other drivers simply don't always notice motorcyclists.

Ride defensively. Wise motorcyclists use a strategy of assuming they are invisible to other drivers, even in broad daylight. Pay careful attention to other motorists, especially at intersections, because they may not be paying attention to you. Select a lane position that gives you the best view of others, and other motorists the best view of you. Wear bright, reflective clothing. Put reflective strips on your helmet.

2. If you don't have a helmet, buy a helmet, and wear it EVERY TIME YOU RIDE.

Most accidents occur within a few miles of home, and almost half occur at speeds of less than 30 mph. So even if you're just going on a quick errand, be prepared — strap on your helmet before you take off.

Helmets do not reduce essential vision or hearing. Generally, helmets do not cause or intensify injury if you crash. Helmets simply help your skull protect your intelligence, your memory, your personality, and your life.

Your eyesight is equally valuable. Wearing suitable eye protection can help keep your vision unblurred by the wind and save your eyes from airborne hazards like bugs, dirt, or pebbles kicked up by tires.

3. If a collision is imminent, DO SOMETHING.

Many riders fear locking up their brakes or haven't learned to swerve to avoid an accident. Many inexperienced riders (and too many seasoned riders) use only their rear brake in an emergency, resulting in unnecessary impacts in some cases and unnecessarily high impact speeds in other cases. Your rear brake can only provide about 30% of your motorcycle's potential stopping power. The front and rear brakes can and should be used together to maximize braking effectiveness.

Experienced motorcyclists learn to "cover" the front brake lever by lightly resting a couple of fingers over the lever when riding in traffic and near intersections to give their reaction time a head start.

Emergency stopping and swerving are techniques that you should practice and master before you find yourself in an emergency situation. The best place to practice such techniques is in a controlled environment such as the Motorcycle Safety Foundation's (MSF) rider training courses. The MSF's Motorcycle RiderCourses (fundamental techniques) and Experienced RiderCourses (advance strategies) present hands-on instruction of the basic principles of motorcycling and a variety of accident-avoidance maneuvers. Even a seasoned motorcyclist can improve his or her riding skills, and pick up a few new skills, through these courses. Some insurance companies even offer discounts to course graduates.

4. Special situations require special care.

Of course, there are some times when full-force braking is not the correct technique. When the road surface is wet, loose, or rough, you should brake with care. When you're leaned over in a corner, avoid braking. Straighten up before braking. Better yet, slow down before entering the corner.

In these situations, the traction available between your tires and the road surface is limited. Overbraking when traction is limited will cause your tires to skid, possibly resulting in loss of directional control or causing you and your motorcycle to fall over.

5. Know your limits.

Always ride within the boundaries of your own skills. Knowing these limits and staying within them will help you avoid accidents.

A major cause of accidents involving only a motorcycle (and no cars) is going too fast through a turn. Before entering a turn, select an appropriately low cornering speed.

Even on straight roads, ride at a speed that is appropriate for the traffic, visibility and road conditions, your motorcycle, and your experience.

Riding a motorcycle safely requires that your mental and physical skills are fully part of the experience. You should not attempt to operate a motor vehicle, especially one with two wheels, if you are tired or under the influence of alcohol or other drugs. Alcohol, illegal drugs, and even some prescription and over-

the-counter drugs can cause drowsiness, loss of coordination, loss of balance, and especially the loss of good judgment. If you are tired or under the influence of alcohol or other drugs, PLEASE DO NOT RIDE your motorcycle.

6. Be extra safety-conscious on bad weather days.

Riding on bad weather days, especially wet ones, requires extra caution. Braking distances increase on a rainy day. Stay off the painted surface marks, manhole covers, and greasy-appearing areas, as they can be especially slippery. Use extra caution at railway crossings and on metal gratings and bridges. When it starts to rain, any oil or grease on the road rises to the surface of the water. Pull over and wait a few minutes until this oil film is washed away before riding. Whenever in doubt about road conditions, slow down!

7. Practice away from traffic.

Your riding skill and your mechanical knowledge form the foundation for safe riding practices. We suggest that you practice riding your motorcycle in a non-traffic situation until you are thoroughly familiar with your machine and its controls. Again, consider taking one of the MSF's RiderCourses.

Even experts will be pleased with the caliber of the information presented in these courses. As the MSF says: "The more you know, the better it gets!"

8. Inspection before riding.

Review the instructions in the "Inspection Before Riding" section of this manual. Perform an entire pre-ride inspection before you head out on the road. Spending a few minutes preparing your machine for a ride can help prevent accidents due to mechanical failure or costly, inconvenient breakdowns far from home.

9. Accessories and Loading

The accessories you use with your motorcycle and the manner in which you load your gear onto the bike might create hazards. Aerodynamics, handling, balance, and cornering clearance can suffer, and the suspension and tires can be overloaded. Read the "Accessory Use and Motorcycle Loading" section.

10. Motorcycle Safety Foundation's "Riding Tips and Practice Guide" Handbook (for owners in USA).

This special handbook, supplied with your owner's manual, contains a variety of safety tips, helpful hints, and practice exercises. This manual can increase your riding enjoyment and safety. You should read it thoroughly.

11. Be street smart.

Always heed speed limits, local laws, and the basic rules of the road. Set a good example for others by demonstrating a courteous attitude and a responsible riding style.

12. Conclusion

Traffic, road and weather conditions vary. Other motorists' actions are unpredictable. Your motorcycle's condition can change. These factors can best be dealt with by giving every ride your full attention.

Circumstances beyond your control could lead to an accident. You need to prepare for the unexpected by wearing a helmet and other protective gear, and learning emergency braking and swerving techniques to minimize the damage to you and your machine.

The best way to learn basic riding skills and evasive maneuvers or refresh your own riding skills is to take one of the courses offered by the Motorcycle Safety Foundation. Your Suzuki dealer can help you locate the fundamental or advanced riding skills course nearest you, or you can call toll-free 1-800-447-4700.

Good riding on your new Suzuki!

ADDITIONAL CONSIDERATION WHEN RIDING OFF-HIGHWAY

A. Off-highway riding calls for off-highway protective gear.

In addition to the reasons cited above for wearing a helmet and eye protection on the street, the trail presents its own hazards. Visibility and trail conditions can vary greatly from section to section and season to season. These changes are sometimes unpredictable, and even an experienced rider can have an accident. There may be branches hanging over the trail at eye level. Wear a helmet and eye protection every time you ride.

Wear protective clothing when you ride. Avoid loose clothes or scarves, which could get caught in moving parts. Abrasion injuries can be minimized by wearing protective clothing including gloves, strong boots that fit over the ankle, long pants, and a long sleeve shirt or jacket. Experienced riders often wear a kidney belt and chest or back protector for additional comfort and protection.

B. **Use the buddy system.**
Share the fun of a good off-road ride. A riding partner can also be a great help if one of you gets stranded or injured. If none of your friends rides off-highway, ask your Suzuki dealer how to go about joining a club. If your friends do ride, you can all join a club — or start one of your own.

C. Obstacles come with the territory.

Negotiating obstacles is a normal part, and often the most fun and challenging part, of off-highway riding. Scan the areas ahead. You may come upon naturally-occurring obstacles such as ruts, bumps. You may encounter animals, other recreational vehicles, trees, low branches, blind corners, or sudden dropoffs, horseback riders, or hikers. The sooner you notice potential obstacles and trail-sharing needs, the sooner you can plan your actions accordingly.

D. Remember: Practice on level ground.

Before you begin riding off-highway, you should find a good place to practice the skills you need to ride safely. Review the Motorcycle Safety Foundation's "Tips and Practice Guide for the Off-Highway Motorcyclist"

Handbook supplied with this owner's manual (for owners in USA). This special handbook contains a variety of safety tips, helpful hints, and practice exercise that can increase your riding enjoyment and safety.

Find a flat, open area with enough space to maneuver. Review local laws to make sure you are not trespassing or violating other ordinances. Check with your Suzuki dealer or call your local park ranger or police department if you do not know where you can ride.

Review the controls on your motorcycle before riding. Learn to find these controls without looking for them. You will not have time to look for them when you are riding, since you will be concentrating on the terrain.

E. Be environmentally conscious.

Protect your right to ride. When you ride, remember to keep the terrain in good condition Tread lightly! Resist the urge to blaze new trails — stay on established trail systems. Don't destroy plant life Leave the area better than you found it. Don't litter — pack out what you packed in. Don't bother wildlife. Don't make your exhaust system

noisier — complaints about noise are one of the biggest threats to the future of our sport. With every rider projecting a courteous and responsible attitude, riding areas can remain open for all to use in the future. You or your riding club may want to volunteer to help your local land manager (usually the U.S. Forest Service, the Bureau of Land Management, or various state agencies) plan, build, and maintain the trail systems you use.

F. Conclusion

If the off-highway environment, visibility and terrain conditions vary. The actions of other users or animals that you encounter on the trail are unpredictable. Your motorcycle's condition can change. These factors can best be dealt with by practicing the appropriate riding techniques and giving every ride your full attention.

FUEL AND ENGINE OIL RECOMMENDATION

FUEL

Suzuki highly recommends that you use alcohol-free unleaded gasoline whenever possible, with a minimum pump octane rating of 87 ((R+M)/2 method) or 91 octane (Research method). In some areas, the only fuels that are available are oxygenated fuels. Oxygenated fuels which meet the minimum octane requirement and the requirements described below may be used in your motorcycle without jeopardizing the New Vehicle Limited Warranty or the Emission Control System Warranty.

NOTE: Oxygenated fuels are fuels which contain oxygen-carrying additives such as MTBE or alcohol.

Gasoline Containing MTBE

Unleaded gasoline containing MTBE (Methyl Tertiary Butyl Ether) may be used in your motorcycle if the MTBE content is not greater than 15%. This oxygenated fuel does not contain alcohol.

Gasoline/Ethanol Blends

Blends of unleaded gasoline and ethanol (grain alcohol), also known as gasohol, may be used in your vehicle if the ethanol content is not greater than 10%.

Gasoline/Methanol Blends

Avoid using blends of unleaded gasoline and methanol (wood alcohol) whenever possible. DO NOT USE fuels containing more than 5% methanol under any circumstances. Fuel system damage or motorcycle performance problems resulting from the use of such fuels are not the responsibility of Suzuki and may not be covered under the New Vehicle Limited Warranty or the Emission Control System Warranty.

Fuel containing 5% or less methanol may be suitable for use in your motorcycle if they contain cosolvents and corrosion inhibitors.

Fuel Pump Labeling

In some states, pumps that dispense oxygenated fuels are required to be labeled for the type and percentage of oxygenate, and whether important additives are present. Such labels may provide enough information for you to determine if a particular blend of fuel meets the requirements listed above. In other states, pumps may not be clearly labeled as to the content or type of oxygenate and additives. If you are not sure that the fuel you intend to use meets these requirements, check with the service station operator or the fuel suppliers.

NOTE:

- *Be sure that any oxygenated fuel blend you use has octane ratings of at least 87 pump octane ((R+M)/2 method).*
- *If you are not satisfied with the driveability or fuel economy of your motorcycle when you are using a gasoline/alcohol blend, you should switch back to unleaded gasoline containing no alcohol.*
- *If engine pinging is experienced, substitute another brand as there are differences between brands.*
- *Unleaded gasoline will extend spark plug life.*

⚠ CAUTION

Spilling gasoline containing alcohol can harm your motorcycle. Alcohol can damage painted surfaces.

Be careful not to spill any fluid when filling the fuel tank. Wipe spilled gasoline up immediately.

ENGINE OIL

Suzuki recommends the use of SUZUKI PERFORMANCE 4 MOTOR OIL or an oil which is rated SE, SF or SG under the API (American Petroleum Institute) classification system. The viscosity rating should be SAE 10W-40. If an SAE 10W-40 oil is not available, select an alternative according to the chart below.

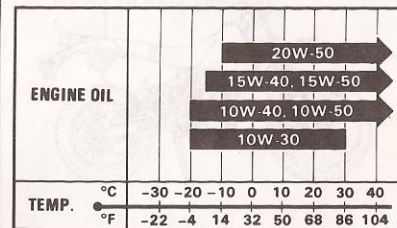

This is a very high performance SAE 10W-40 SG oil with special friction modifier added.

LOCATION OF LABELS

Read and follow all of the warnings labeled on your motorcycle. Make sure you understand all of the labels. Keep the labels on your motorcycle. Do not remove them for any reason.

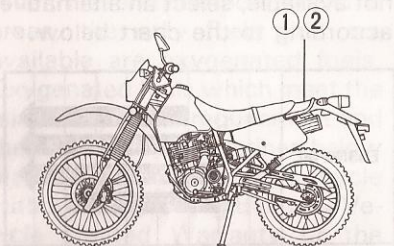

①

⚠ WARNING

Failure to follow these safety precautions may increase your risk of injury:

- Wear a helmet, eye protection, and bright protective clothing.
- Don't ride after consuming alcohol or other drugs.
- Slow down on slippery roads, unfamiliar terrain, or when visibility is reduced.
- Read owner's manual carefully.

②

| TIRE INFLATION PRESSURE PRESSION OU PNEU A L'ETAT GONFLE | SOLO RIDING COURSE SOLO | | | DUAL RIDING COURSE A DEUX CONOUCTEURS | | |
|--|-------------------------|-----|--------------------|---------------------------------------|-----|--------------------|
| | KG/CM ² | kPa | LB/IN ² | KG/CM ² | kPa | LB/IN ² |
| FRONT AVANT | 1.50 | 150 | 22 | 1.50 | 150 | 22 |
| REAR ARRIERE | 1.50 | 150 | 22 | 1.75 | 175 | 25 |
| TIRE SIZE DIMENSIONS OU PNEU | FRONT AVANT | | 80/100-21 51P | | | |
| | REAR ARRIERE | | 110/90-18 61P | | | |
| <ul style="list-style-type: none"> ● TIRE PRESSURE SHOULD BE MEASURED WHEN TIRE IS IN COLD CONDITION. ● MESURER LA PRESSION OU PNEU A FROID. | | | | | | |

LOCATION OF PARTS

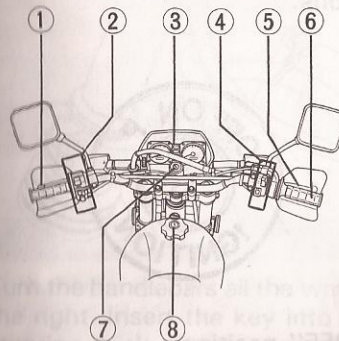

- 1 Clutch lever
- 2 Left handlebar switches
- 3 Instrument panel
- 4 Right handlebar switches
- 5 Front brake lever
- 6 Throttle grip
- 7 Ignition switch
- 8 Fuel tank cap

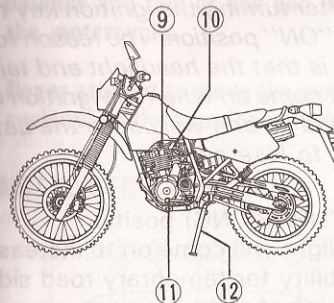

- 9 Fuelcock
- 10 Carburetor choke knob
- 11 Gearshift lever
- 12 Side Stand

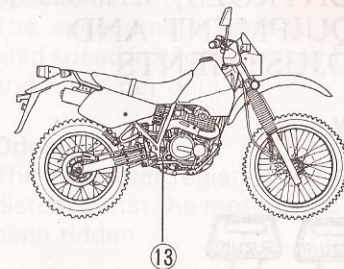

- 13 Rear brake pedal

CONTROLS, EQUIPMENT AND ADJUSTMENTS

KEY

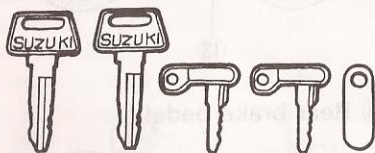

This motorcycle comes equipped with two pairs of keys, one for the ignition switch and the other for the steering lock.

The ignition keys are stamped with an identifying number. The steering lock keys have no number on them and instead the number is stamped on a plate provided with the steering lock keys.

Please write your key numbers in the box provided for your future reference.

| Key No. | Ignition | |
|---------|----------|--|
| | Steering | |

IGNITION SWITCH

The ignition switch has 3 positions.



"OFF" position

All electrical circuits are off. The engine will not start.

"ON" position

The ignition circuit is completed and the engine can run. You cannot remove the key from the ignition switch in this position.

NOTE: Start the engine promptly after turning the ignition key to the "ON" position. The reason for this is that the headlight and taillight come on when the ignition is turned on and will cause the battery to lose power.

"P" (PARKING) position

Taillight will come on to increase visibility for temporary road side parking at night. You can remove the ignition key in this position.

STEERING LOCK

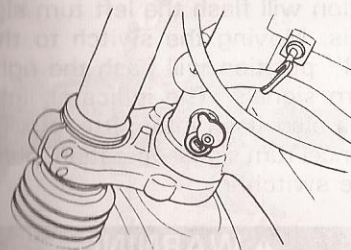

Turn the handlebars all the way to the right. Insert the key into the steering lock, turn it counterclockwise and push it further in. Turn the key clockwise (to normal position) and pull out the key. The steering is now locked.

▲ WARNING

Moving the motorcycle while the steering is locked can be hazardous. You could lose your balance and fall, or you can drop the motorcycle.

Never attempt to move the motorcycle when the steering is locked.

INSTRUMENT PANEL

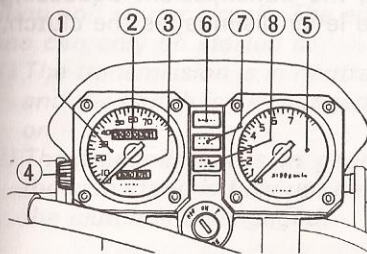

Speedometer ①

The speedometer indicates the road speed in kilometers per hour and miles per hour.

Odometer ②

The odometer registers the total distance that the motorcycle has been ridden.

Trip Meter ③

The trip meter is a resettable odometer located in the speedometer assembly. It can be used to indicate the distance traveled on short trips or between fuel stops. Turning knob ④ counterclockwise will return the meter to zero.

Tachometer ⑤

The tachometer indicates the engine speed in revolutions per minute (r/min).

Turn Signal Indicator Light ⑥

When either the right or left turn signals are being operated, the indicator light will flash intermittently.

NOTE: If a turn signal light is not operating properly due to bulb filament or circuit failure, the indicator light does not flicker but remains lit to notify the rider of the existence of the failure.

High Beam Indicator Light ⑦

The blue indicator light will be lit when the headlight high beam is turned on.

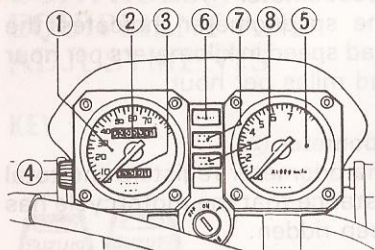

Neutral Indicator Light ⑧

The green indicator light will come on when the transmission is in neutral. The light will go out when you shift into any gear other than neutral.

LEFT HANDLEBARS

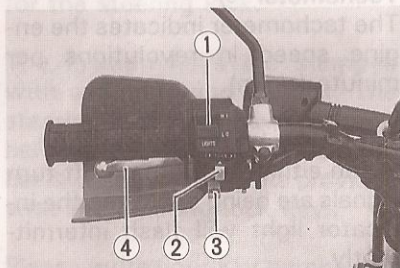

Dimmer Switch ①

"LO" position

The headlight low beam and tail-light turn on.

"HI" position

The headlight high beam and tail-light turn on. The high beam indicator light also turns on.

Turn Signal Switch ②

Moving the switch to the "L" position will flash the left turn signals. Moving the switch to the "R" position will flash the right turn signals. The indicator light will also flash intermittently. To cancel turn signal operation, push the switch in.

▲ WARNING

Failure to use the turn signals, and failure to turn off the turn signals can be hazardous. Other drivers may misjudge your course and this may result in an accident.

Always use the turn signals when you intend to change lanes or make a turn. Be sure to turn off the turn signals after completing the turn or lane change.

Horn Button ③

Press the button to operate the horn.

Clutch Lever ④

The clutch lever is used to disengage the drive to the rear wheel when starting the engine or shifting the transmission. Squeezing the lever disengages the clutch.

RIGHT HANDLEBARS

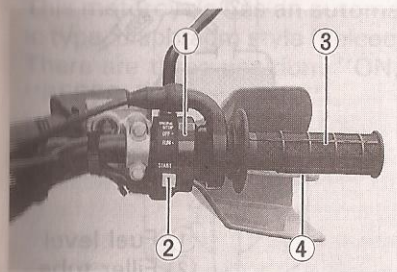

Engine Stop Switch ①

"OFF" position

The ignition circuit is off. The engine cannot start or run.

"RUN" position

The ignition circuit is on and the engine can run.

Electric Starter Button ②

Use this button to turn the starter motor. With the ignition switch in the "ON" position and the engine stop switch in the "RUN" position, and the transmission is in neutral, pull in the clutch lever and push the electric starter button to start the engine.

NOTE: This motorcycle has a starter interlock system for the ignition and starter circuit. The engine can only be started if:

- (1) *The transmission is in neutral and the clutch is disengaged, or*
- (2) *The transmission is in gear, the side stand is fully up, and the clutch is disengaged.*

▲ CAUTION

Engaging the starter motor for more than five seconds at a time can damage the motorcycle. The starter motor and wiring harness may overheat.

If the engine does not start after several attempts, check the fuel supply and ignition system. Refer to the TROUBLESHOOTING section in this manual.

Throttle Grip ③

Engine speed is controlled by the position of the throttle grip. Turn it toward you to increase engine speed. Turn it away from you to decrease engine speed.

Front Brake Lever ④

Apply the front brake by squeezing the front brake lever towards the grip. The brake light will come on when the lever is squeezed.

Front Brake Lever Adjustment

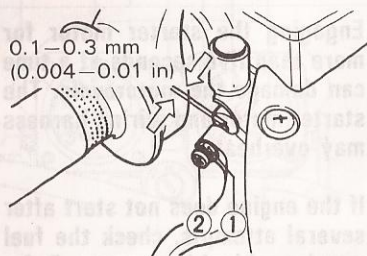

Adjust the front brake lever play as follows:

- (1) Loosen the lock nut ①.
- (2) Turn the adjusting screw ② in or out to obtain the correct clearance of 0.1 – 0.3 mm (0.004 – 0.01 in).
- (3) Tighten the lock nut securely.

FUEL TANK CAP

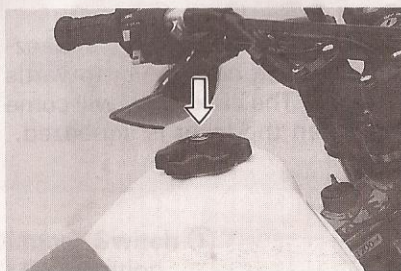

To open the fuel tank cap, insert the ignition key and turn it counterclockwise. Turn the cap counterclockwise and remove it. To close the fuel tank cap, turn it clockwise. The key must be in the cap lock before installing the cap. Turn the key clockwise and remove it.

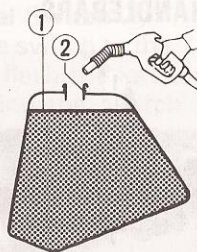

- ① Fuel level
- ② Filler tube

⚠ WARNING

Overfilling the fuel tank can be hazardous. If you overfill the fuel tank, fuel may overflow when it expands. Fuel expands due to engine heat or heating by the sun. Overheated fuel can easily catch fire.

Stop adding fuel when the fuel level reaches the bottom of the filler tube.

⚠ WARNING

Improper fueling of the motorcycle can be hazardous. Failure to follow safety precautions when refueling could result in a fire or cause you to breathe toxic fumes.

Refuel in a well ventilated area. Turn the engine off and avoid spilling fuel on a hot engine. Do not smoke, and make sure there are no open flames or sparks in the area. Avoid breathing gasoline vapors. Keep children away when you refuel the motorcycle.

FUELCOCK

This motorcycle has an automatic type, diaphragm style fuelcock. There are three position: "ON," "RESERVE" and "PRI."

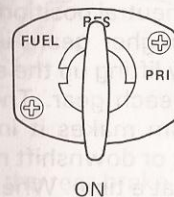

"ON" position

The normal position for the fuelcock is in the "ON" position. In this position, no fuel will flow from the fuelcock to the carburetors unless the engine is running or being started.

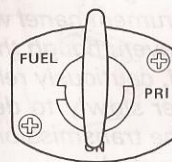

RESERVE

"RESERVE" position

If the fuel level in the fuel tank becomes too low for the engine to operate with the fuelcock lever in the "ON" position, turn the lever to the "RESERVE" position to use the reserve fuel supply. In this position, no fuel will flow from the fuelcock to the carburetors unless the engine is running or being started.

RESERVE FUEL SUPPLY: 2.0 L (0.5 US gal)

NOTE: After switching the fuelcock lever to the "RESERVE" position, it is advisable that the tank be refilled at the closest gas station. After refueling, be sure to move the fuelcock to the "ON" position.

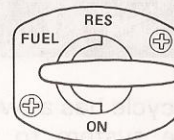

PRI

"PRI" position

If the motorcycle has run out of fuel or has been stored for an extended period, there may not be any gasoline in the carburetors. In this instance the fuelcock should be moved to the "PRI" position. This will allow the fuel to flow directly into the carburetors even though the engine is not operating. Upon starting the engine, be sure to return the fuelcock to the "ON" position.

⚠ WARNING

Leaving the fuelcock in "PRI" position when the engine is off can be hazardous. The carburetor may overflow and fuel may run into the engine. This can cause a fire or cause severe damage when you start the engine.

Always leave the fuelcock in the "ON" or "RESERVE" position when the engine is not running.

CARBURETOR CHOKE KNOB

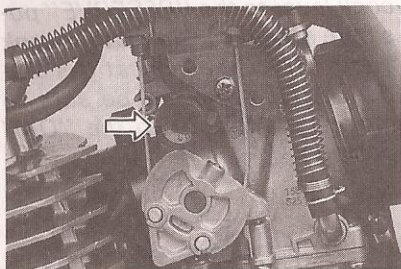

This motorcycle has a two-stage type choke system to provide easy starting when the engine is cold. The choke works by pulling out the choke knob. The choke works best when the throttle is in the closed position. When the engine is warm, you do not need to use the choke for starting.

NOTE: Refer to the **STARTING THE ENGINE** section of the manual for the engine starting procedure.

GEARSHIFT LEVER

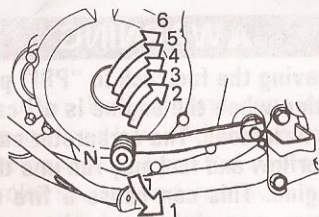

This motorcycle has a 6-speed transmission which operates as shown. This shift lever is attached to a ratchet type mechanism

in the transmission. Each time you select a gear, the gearshift lever will return to its normal position ready to select the next gear. Engage first gear by depressing the lever downward from the neutral position. Shifting into the higher gears is accomplished by lifting up the shift lever once for each gear. The ratchet mechanism makes it impossible to upshift or downshift more than one gear at a time. When shifting from the low to 2nd gear or 2nd gear to low, neutral will be automatically skipped. When neutral is desired, press or lift the lever to a position halfway between low and 2nd gear.

NOTE: When the transmission is in neutral the green indicator light on the instrument panel will be lit. However, even though the light is illuminated, cautiously release the clutch lever slowly to determine whether the transmission is positive in neutral.

REAR BRAKE PEDAL

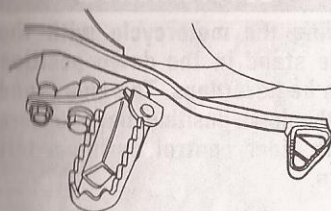

Pressing the rear brake pedal will apply the rear brake. The brake light will come on when the rear brake is operated.

HELMET HOLDER

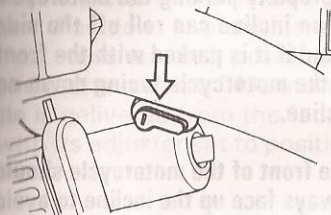

To open the latch of the helmet holder, insert the ignition key into the lock and turn it clockwise. To close the latch, turn the key counterclockwise.

▲ WARNING

Operating the motorcycle with a helmet fastened to the helmet holder can be hazardous. A helmet may interfere with your control while riding.

Do not fasten helmets to the helmet holders before riding.

SIDE STAND

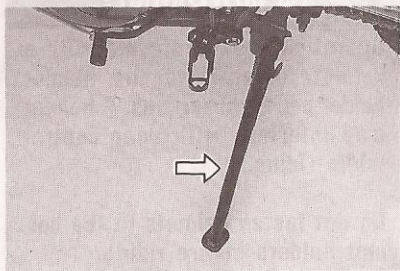

The motorcycle has a side stand. To place the motorcycle on the side stand, place your right foot on the end of the side stand and push down firmly until the stand pivots fully through its arc and comes to rest against it stop.

An interlock system is provided to cut off the ignition circuit when the side stand is down and the transmission is in any gear other than neutral.

The side stand/ignition interlock system works as follows:

- (1) If the side stand is down and the transmission is in gear, the engine can not be started.
- (2) If the engine is running and the transmission is shifted into gear with the side stand down, the engine will stop running.
- (3) If the engine is running and the side stand is put down with the transmission in gear, the engine will stop running.

⚠ WARNING

Riding the motorcycle with the side stand in the down position can be hazardous. The side stand in the down position may interfere with rider control during a left turn.

- Check the side stand/ignition interlock system for proper operation before riding.
- Check that the side stand is returned to its full up position before starting off.

⚠ CAUTION

Improperly parking the motorcycle on an incline can roll off the side stand if it is parked with the front of the motorcycle facing down an incline.

The front of the motorcycle should always face up the incline to avoid rolling forward off the side stand. Put the transmission into 1st gear to help prevent the motorcycle from rolling off the side stand.

FRONT SUSPENSION

Spring Adjustment



The front suspension springs have six adjustable preload positions. To change the spring preload settings, place the motorcycle on level ground and on the side stand. Adjust them by turning the adjuster to the desired position. Position 1 provides the stiffest tension and position 6 provides the softest. This motorcycle is delivered from the factory with its adjuster set to position 3.



Position 1

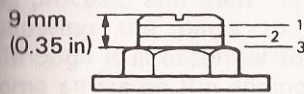

Position 3

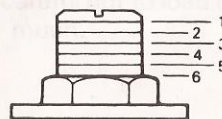

Position 6

⚠ WARNING

Unevenly adjusting the right and left front suspension can be hazardous. Making one spring stiffer than the other can result in handling problems that may cause an accident.

Adjust the right and left springs to the same preload setting.

Damping Force Adjustment

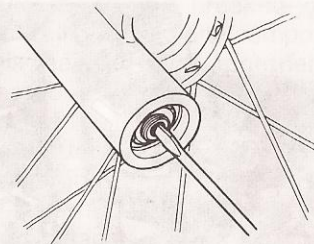

The damping force can be adjusted by turning the adjuster. The damping force adjuster is located at the bottom of the front fork. To adjust the damping force, turn in the adjuster fully and turn it out. As you turn the adjuster, you will notice the clicks. Count the number of clicks from the fully turned-in position. Fully turned-in position provides stiffest damping force and turning out the adjuster will soften damping force. The damping force is set on 7 clicks position at the factory.

⚠ WARNING

Unevenly adjusting the right and left front suspension damping force can result in handling problems that may cause an accident.

Adjust the right and left damping force to the same setting.

REAR SUSPENSION Spring Preload Adjustment

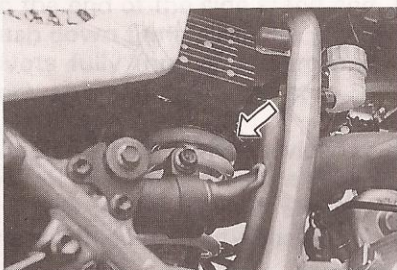

The spring preload adjustment can be performed by changing the adjuster ring position. However, Suzuki recommends that this adjustment be done by your authorized Suzuki dealer since a special tool is necessary for this job.

Damping Force Adjustment

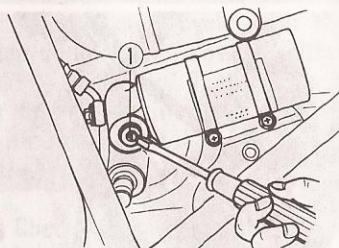

The damping force adjuster is located at the bottom of the front fork. To adjust the damping force, turn in the adjuster fully and turn it out. As you turn the adjuster, you will notice the clicks. Count the number of clicks from the fully turned-in position. Fully turned-in position provides stiffest damping force and turning out the adjuster will soften damping force. The damping force is set on 7 clicks position at the factory.

BREAK-IN

The first 800 km (500 miles) is the most important in the life of your motorcycle. Proper operation during this break-in period will help assure maximum life and performance from your new vehicle. The following guidelines explain proper break-in procedures.

Maximum Engine Speed Recommendation

The table below shows the maximum engine speed recommendation during the break-in period.

| | |
|------------------------------|-------------------|
| Initial 800 km (500 miles) | Below 5 000 r/min |
| Up to 1 600 km (1 000 miles) | Below 6 000 r/min |
| Over 1 600 km (1 000 miles) | Below 9 500 r/min |

Vary the Engine Speed

Vary the engine speed during the break-in period. This allows the parts to "load" (aiding the mating process) and then "unload" (allowing the parts to cool). Although it is essential to place some stress on the engine components during break-in, you must be careful not to load the engine too much.

Allow the Engine Oil to Circulate before Riding

Allow enough idling time after warm or cold engine start up before revving the engine or placing the transmission in gear. This allows time for the lubricating oil to reach all critical engine components.

Observe Your Initial and Most Critical Service

The initial service (break-in maintenance) is the most important service your motorcycle will receive. During break-in operation, all of the engine components will have mated together and seated. Maintenance required as part of the initial service includes correction of all adjustments, tightening of all fasteners and replacement of dirty oil. Timely performance of this service will help make sure you get the best service life and performance from the engine.

INSPECTION BEFORE RIDING

⚠ WARNING

Failure to inspect the motorcycle before operating it can be hazardous. Failure to perform proper maintenance can also be hazardous. Failure to inspect and maintain your motorcycle increases the chance of an accident or equipment damage.

Always inspect your motorcycle each time you use it to make sure it is in safe operating condition. Refer to the INSPECTION AND MAINTENANCE section in this owner's manual.

⚠ WARNING

Operating this motorcycle with improper tires can be hazardous. If you use improper tires, you may lose control of the motorcycle. This will increase your risk of an accident.

Always use the size and type tires specified in this owner's manual. Always maintain proper tire pressure as described in the INSPECTION AND MAINTENANCE section.

Check the condition of the motorcycle to help make sure that you do not have mechanical problems or get stranded somewhere when you ride. Before riding the motorcycle, be sure to check the following items. Be sure your motorcycle is in good condition for the personal safety of the rider, passenger and protection of the motorcycle.

⚠ WARNING

Checking maintenance items when the engine is running can be hazardous. You could be severely injured if your hands or clothing get caught in moving parts.

Shut the engine off when performing maintenance checks, except when checking the engine stop switch and throttle.

| WHAT TO CHECK | CHECK FOR |
|-------------------------|--|
| Steering (Direction) | 1) Smoothness 2) No restriction of movement 3) No play or looseness |
| Brakes (Fronts) | 1) Correct fluid level 2) No fluid leakage 3) No "sponginess" 4) Proper pedal and lever play 5) Brake pad wear |
| Tires (Gomas) | 1) Proper pressure 2) Enough tread depth 3) No cracks, rips, or other damage |
| Fuel tank | Tank cap locked securely |

| | |
|---------------------------------------|---|
| Lighting | Proper operation of all lights - Headlight, Taillight, Brake light, Instrument lights, Turn signals |
| Indicator lights | Proper operation of all lights - High beam, Neutral, Turn signal |
| Engine stop switch | Proper operation |
| Horn | Correct function |
| Engine oil | Correct level |
| Throttle | 1) Proper play 2) Smooth response 3) Quick return to idle position |
| Gearshift lever | 1) No damage 2) Smooth operation |
| Drive chain | 1) Proper tension 2) Adequate lubrication 3) No excessive wear or damage |
| Side stand /ignition interlock system | Proper operation |
| General condition | 1) Bolts and nuts tightness 2) No rattle from any parts of machine with the engine running 3) No visible evidence of damage |

RIDING TIPS

STARTING THE ENGINE

Before attempting to start the engine, make sure:

- (1) The transmission is in neutral.
- (2) The fuelcock is in the "ON" position.
- (3) The engine stop switch is in the "RUN" position.

NOTE: This motorcycle has interlock switches for the ignition circuit and the starter circuit. The engine can only be started if:

- (1) *The transmission is in neutral and the clutch is disengaged, or*
- (2) *The transmission is in gear, the side stand is fully up, and the clutch is disengaged.*

When the Engine Is Cold:

- (1) Pull out the choke knob fully.
- (2) With the throttle grip in the fully closed position, push the electric Starter button.
- (3) Immediately after the engine starts, keep the engine speed at 2 000 r/min by varying the choke knob position.
- (4) Move the choke knob to the "OFF" position approximately 30 seconds after engine starts. It may be necessary to use the choke longer than 30 seconds in extremely cold weather.

When the Cold Engine Is Hard to Start:

- (1) Pull out the choke knob fully.
- (2) With the throttle grip opened 1/8 to 1/4, push the electric starter button.
- (3) Immediately after the engine starts, keep the engine speed at 2 000 r/min by varying the choke knob position.
- (4) Move the choke knob to the "OFF" position approximately 30 seconds after engine starts. It may be necessary to use the choke longer than 30 seconds in extremely cold weather.

When the Engine Is Warm:

- (1) Confirm that the choke knob is in the "OFF" position.
- (2) With the throttle grip in the fully closed position, push the electric starter button.

NOTE: Operation of the carburetor choke system is usually not necessary when the engine is warm.

When the Warm Engine Is Hard to Start:

- (1) Confirm that the choke knob is in the "OFF" position.
- (2) With the throttle grip opened 1/8 to 1/4, push the electric starter button.

▲ WARNING

Never run the engine indoors or in a garage. Exhaust gas contains carbon monoxide, a gas that is colorless and odorless and can cause death or severe injury.

Only run the engine outdoors where there is fresh air.

▲ WARNING

This motorcycle can start moving as soon as you start the engine with the transmission in gear. Unexpected movement can cause you to lose control of the motorcycle.

Be sure to shift into neutral and disengage the clutch before you start the engine.

▲ CAUTION

Running the engine too long without riding may cause the engine to overheat. Overheating can result in damage to internal engine components and discoloration of exhaust pipe.

Shut the engine off if you cannot begin your ride promptly.

STARTING OFF AND SHIFTING

▲ WARNING

Operating this motorcycle at excessive speeds can be hazardous. Riding at excessive speeds increases your chances of losing control of the motorcycle, which can result in an accident.

Always go at a speed that is proper for the terrain, visibility and operating conditions, and your experience.

▲ WARNING

Removing your hands from the handlebars or feet from the footrests during operation can be hazardous. If you remove even one hand or foot from the motorcycle, you can reduce your ability to control the motorcycle.

Always keep both hands on the handlebars and both feet on the footrests of your motorcycle during operation.

▲ WARNING

Riding in sudden side winds can be hazardous. Sudden side winds, which can occur when being passed by larger vehicles, at tunnel exits, or in hilly areas, can upset your control.

Reduce your speed and ride alertly in side winds.

Make sure that the side stand is in the fully up position. Pull the clutch lever in and pause momentarily. Engage first gear by depressing the gearshift lever downward. Turn the throttle grip toward you and at the same time release the clutch lever gently and smoothly. As the clutch engages, the motorcycle will start moving forward. To shift to the next higher gear, accelerate gently, then close the throttle and pull the clutch lever in simultaneously. Lift the gear shift lever upward to select the next gear and release the clutch lever as you open the throttle again. Select the gears in this manner until top gear is reached.

NOTE: This motorcycle has a side stand/ignition interlock switch. If you shift the transmission into gear when the side stand is down, the engine will stop running.

▲ WARNING

Riding the motorcycle with the side stand in the down position can be hazardous. The side stand in the down position may interfere with rider control during a left turn.

Check that the side stand is returned to its full up position before starting off.

USING THE TRANSMISSION

The transmission is provided to keep the engine operating smoothly in its normal operating speed range. The gear ratios have been carefully chosen to meet the characteristics of the engine. The rider should always select the most suitable gear for the prevailing conditions. Never slip the clutch to control road speed, but rather downshift to allow the engine to run within its normal operational range. The table below shows the approximate speed range for each gear.

Shifting up schedule

| Gear position | miles/h | km/h |
|---------------|---------|------|
| 1st→2nd | 12 | 20 |
| 2nd→3rd | 19 | 30 |
| 3rd→4th | 25 | 40 |
| 4th→5th | 31 | 50 |
| 5th→6th | 37 | 60 |

Shifting down schedule

| | | |
|---------|----|----|
| 6th→5th | 31 | 50 |
| 5th→4th | 25 | 40 |
| 4th→3rd | 19 | 30 |
| 3rd→2nd | 12 | 20 |

Disengage the clutch when the motorcycle speed drops below 10 km/h (6 miles/h).

⚠ WARNING

Downshifting at too high a speed can

- 1) **Cause the rear wheel to skid and lose traction due to increased engine braking, resulting in an accident; or**
- 2) **Force the engine to overrev in the lower gear, resulting in engine damage.**

Reduce speed before downshifting.

⚠ WARNING

Downshifting in a corner can be hazardous. Downshifting while the motorcycle is leaned over may cause your rear tire to skid. This may result in an accident.

Reduce your speed or downshift before entering the corner.

⚠ CAUTION

Revvng the engine into the red zone can cause severe engine damage.

Never allow the engine to rev into the red zone in any gear.

RIDING ON HILLS

- When climbing steep hills, the motorcycle may begin to slow down and show lack of power. At this point you should shift to a lower gear so that the engine will again be operating in its normal power range. Shift rapidly to prevent the motorcycle from losing momentum.
- When riding down a steep hill, the engine may be used for braking by shifting to a lower gear.
- Be careful, however, not to allow the engine to overrev.

STOPPING AND PARKING

- Turn the throttle grip away from you to close the throttle completely.
- Apply the front and rear brakes evenly and at the same time.
- Downshift through the gears as motorcycle speed decreases.
- Select neutral with the clutch lever squeezed towards the grip (disengaged position) just before the motorcycle stops. Neutral position can be confirmed by observing the neutral indicator light.

⚠ WARNING

Inexperienced riders tend to underutilize the front brake. This can cause excessive stopping distance and lead to a collision. Using only the front or rear brake can cause skidding and loss of control.

Apply both brakes evenly and at the same time.

⚠ WARNING

Braking while turning the motorcycle can be hazardous. Hard braking while turning could cause loss of control.

Use the brakes to slow down before you begin to turn.

⚠ WARNING

Braking hard on slippery surfaces can be hazardous. The motorcycle can skid and go out of control if you brake too hard.

Apply the brakes lightly and with care on slippery surfaces.

- (5) Backrests, saddlebags, travel trunks, etc., may affect the stability of the motorcycle due to their aerodynamic effects. The motorcycle may be affected by a lifting condition or by an instability in cross winds or when being passed by or passing large vehicles. Improperly mounted or poorly designed accessories can result in an unsafe riding condition, therefore caution should be used when selecting and installing all accessories.
- (6) Certain accessories displace the rider from his or her normal riding position. This limits the freedom of movement of the rider and may limit control ability.
- (7) Additional electrical accessories may overload the existing electrical system. Severe overloads may damage the wiring harness or create a hazardous situation due to the loss of electrical power during the operation of the motorcycle.

When carrying a load on the motorcycle, mount it as low as possible and as close as possible to the machine. An improperly mounted load can create a high center of gravity which is very hazardous and makes the motorcycle difficult to handle. The size of the "load" can also affect the aerodynamics of the motorcycle. Balance the load between the right and left sides of the motorcycle and fasten it securely.

MODIFICATION

Modification of the motorcycle, or removal of original equipment may render the vehicle unsafe or illegal. Obey all applicable equipment regulations in your area.

INSPECTION AND MAINTENANCE

NOTICE

MAINTENANCE, REPLACEMENT OR REPAIR OF THE EMISSION CONTROL DEVICES AND SYSTEMS MAY BE PERFORMED BY ANY MOTORCYCLE REPAIR ESTABLISHMENT OR INDIVIDUAL USING ANY MOTORCYCLE PART WHICH HAS BEEN CERTIFIED UNDER THE PROVISIONS IN THE CLEAN AIR ACT Sec. 207 (a)(2).

MAINTENANCE SCHEDULE

It is very important to inspect and maintain your motorcycle regularly. Follow the guidelines in the chart. The intervals between periodic services in kilometers, miles and months are shown. At the end of each interval, be sure to perform the maintenance listed.

▲ WARNING

Improper maintenance or failure to perform recommended maintenance can be hazardous. Poor maintenance increases the chance of an accident or equipment damage.

Keep your motorcycle in good condition. Ask your Suzuki dealer or a qualified mechanic to do the maintenance items marked with an asterisk (*). You may perform the unmarked maintenance items by referring to the instructions in this section, if you have mechanical experience. If you are not sure how to do any of the jobs, ask your Suzuki dealer to do the maintenance.

▲ WARNING

Never run the engine indoors or in a garage. Exhaust gas contains carbon monoxide, a gas that is colorless and odorless and can cause death or severe injury.

Only run the engine outdoors where there is fresh air.

⚠ CAUTION

If you use your motorcycle under severe conditions, it will need maintenance more often than shown in the chart. Operating your motorcycle under severe conditions causes more wear on your motorcycle.

Perform maintenance more often than shown in the chart. If you have any questions regarding maintenance intervals, consult your Suzuki dealer.

⚠ CAUTION

Using poor quality replacement parts can cause your motorcycle to wear more quickly and may shorten its useful life.

When replacing parts on your motorcycle use only genuine Suzuki replacement parts or their equivalent.



MAINTENANCE CHART

| Item | Interval | X | | | | |
|---|----------|---|------|------|-------|-------|
| | | miles | 600 | 3000 | 6000 | 9500 |
| | | km | 1000 | 5000 | 10000 | 15000 |
| | month | 3 | 15 | 30 | 45 | |
| Battery | | — | I | I | (I) | |
| Cylinder head bolts and nuts, cylinder nuts, exhaust pipe bolts and muffler connections | | T | T | T | (T) | |
| Valve clearance | | I | I | I | (I) | |
| Spark plug (Bosch) | | — | I | R | (I) | |
| Air cleaner | | Clean every 3000 km (2000 miles) | | | | |
| Engine oil hoses | | I | I | I | (I) | |
| Engine oil and oil filter | | R | R | R | (R) | |
| Oil strainer | | C | C | C | (C) | |
| Fuel line | | I | I | I | (I) | |
| Vapor hose (California model) | | * Replace every four years | | | | |
| Carburetor | | I | I | I | (I) | |
| Clutch | | I | I | I | (I) | |
| Drive chain | | Clean and lubricate every 1000 km (600 miles) | | | | |
| | | I | I | I | (I) | |
| Brakes | | I | I | I | (I) | |
| Brake fluid | | I | I | I | (I) | |
| | | * Replace every two years | | | | |
| Brake hose | | I | I | I | (I) | |
| | | * Replace every four years | | | | |
| Tires | | I | I | I | (I) | |
| Spark arrester | | — | C | C | (C) | |
| Steering | | I | I | I | (I) | |
| Front forks | | I | I | — | (I) | |
| Rear suspension | | I | I | — | (I) | |
| Chassis bolts and nuts | | T | T | T | (T) | |

NOTE: C = Clean, R = Replace, T = Tighten (Adjust)

I = Inspect and clean, adjust, lubricate or replace, as necessary

* = This maintenance should be performed by Suzuki dealer.

mile a lot - 19140 - 23358 - 28500 - 32000 - 34500 -

37.000 -

TOOLS

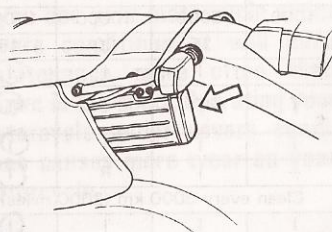

A tool kit is provided with your motorcycle. It is located in the box.

GENERAL LUBRICATION

Proper lubrication is important for safe, smooth operation and a long life for your motorcycle. Be sure that all lubrication is performed during periodic maintenance on the motorcycle. Increase frequency when you use your motorcycle in severe conditions.

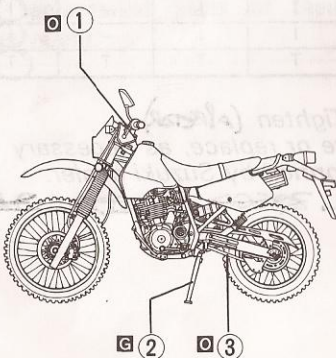

- ①... Clutch lever holder and clutch cable
- ②... Side stand pivot and spring hook
- ③... Drive chain
- ④... Throttle cable
- ⑤... Brake lever holder
- ⑥... Brake pedal pivot

- ... Motor oil
- ... Grease

BATTERY

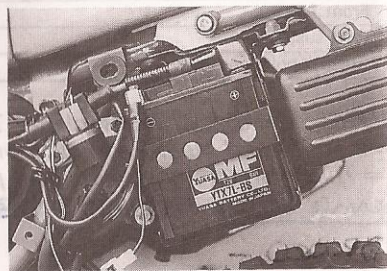

The battery is a sealed type and requires no maintenance. The standard charging rate is 0.7 A x 5 hours and the maximum rate is 3.0 A x 1 hour.

▲ WARNING

Hydrogen gas produced by batteries can explode if exposed to flames or sparks.

Keep flames and sparks away from the battery. Never smoke when working near the battery.

▲ CAUTION

Exceeding the maximum charging rate for the battery can shorten its life.

Never exceed the maximum charging rate.

AIR CLEANER

The air cleaner element must be kept clean to provide good engine power and gas mileage. If you use your motorcycle under normal low-stress conditions, you should service the air cleaner at the intervals specified. If you ride in dusty, wet, or muddy conditions, you will need to inspect the air cleaner element much more frequently. Use the following procedure to remove the element and inspect it.

▲ WARNING

Operating the engine without the air cleaner element in place can be hazardous. A flame can spit back from the carburetor to the air intake box without the air cleaner element to stop it. Severe engine damage can also occur if dirt enters the engine due to running the engine without the air cleaner element.

Never run the engine without the air cleaner element in place.

▲ CAUTION

Failure to inspect the air cleaner element frequently if the motorcycle is used in dusty, wet or muddy conditions can damage your motorcycle. The air cleaner element can become clogged under these conditions, and cause poor performance and fuel economy.

Always check the air cleaner element after riding in severe conditions. Clean or replace the element as necessary. If water gets in the air cleaner case, immediately clean the element and the inside of the case.

Removing the Element

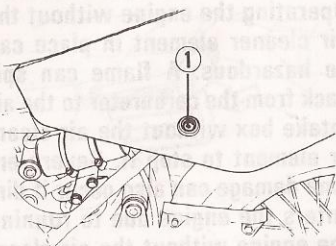

- (1) Loosen the screw ① and remove the left side frame cover.

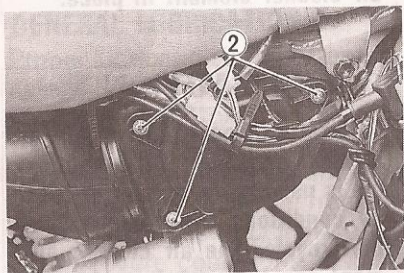

- (2) Remove the air cleaner fitting screws ②.

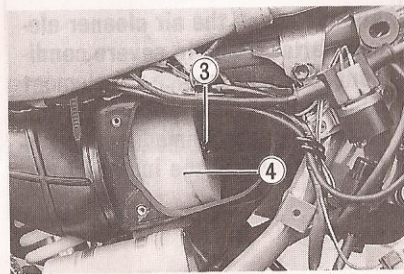

- (3) Remove the nut ③ and take off the polyurethane foam element ④.
- (4) Separate the polyurethane foam element from the frame.

Washing the Element

Wash the element as follows:

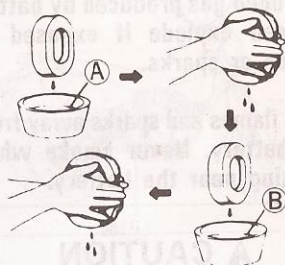

- (1) Fill a wash pan larger than the element with a non-flammable cleaning solvent (A). Dip the element in the solvent and wash it.
- (2) Squeeze the element by pressing it between the palms of both hands to remove the excess solvent. Do not twist or wring the element or it will develop cracks.
- (3) Dry the element.
- (4) Put the element in a plastic bag. Pour in some air filter oil (B) and work the oil into the element.
- (5) Squeeze the element to remove the excess oil.

▲ CAUTION

A torn air filter can damage your motorcycle. Dirt and dust can get inside the engine if the element is torn.

Carefully examine the element for tears before and after cleaning it. Replace the element with a new one if it is torn.

- (6) Clean any dirt or debris from inside the air cleaner case. Be sure no dirt enters the carburetor.
- (7) Reinstall the cleaner element in reverse order of removal. Be sure that the element is securely in position and is properly sealed.

▲ WARNING

Oil and solvent can be hazardous. Children and pets can be harmed from contact with oil and solvent.

Be sure to keep oil and solvent away from children and pets. Dispose of used oil and solvent properly.

▲ CAUTION

Failure to position the air cleaner element properly can damage your motorcycle. Dirt can bypass the air cleaner element if the element is not positioned properly. This will cause the engine parts to wear more rapidly.

Be sure to position the air cleaner element properly.

SPARK PLUG

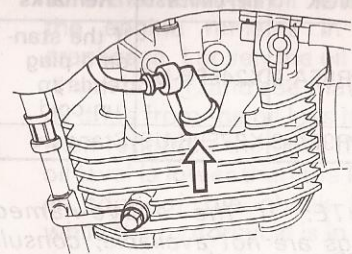

Your motorcycle comes equipped with **NGK DPR9EA-9** or **NIPPON-ONDENSO X27EPR-U9** spark plug. To determine if the standard spark plug is right for your usage, check the color of the plug's porcelain center electrode insulator after motorcycle operation. A light brown color indicates that the plug is correct. A white or dark insulator indicates that the engine may need adjustment, or another plug type may be needed. Consult your Suzuki dealer or qualified mechanic if your plug insulator is not a light brown color.

▲ CAUTION

Failure to use the proper spark plug can be hazardous. An improper spark plug may have an incorrect fit or heat range for your engine. This may cause severe engine damage which may not be covered under warranty.

Use one of the spark plugs listed below or equivalent. Consult you Suzuki dealer if you are not sure which spark plug is correct for your type of usage.

| NGK | NIPPONDENSO | Remarks |
|----------|-------------|--|
| DPR8EA-9 | X24EPR-U9 | If the standard plug tends to run cold |
| DPR9EA-9 | X27EPR-U9 | Standard |

NOTE: If the above-named plugs are not available, consult your Suzuki dealer.

To install a spark plug, turn it in as far as possible with your fingers, then tighten it with a wrench.

⚠ CAUTION

Improper installation of the spark plug can damage your motorcycle. An overly tight or cross threaded plug will damage the aluminum threads of the cylinder head.

Carefully turn the spark plug by hand into the threads. If the spark plug is new, tighten it with a wrench about 1/2 turn past finger tight. If you are reusing the old spark plug, tighten it with a wrench about 1/8 turn past finger tight.

⚠ CAUTION

Dirt can damage your motorcycle if it enters an open spark plug hole. Dirt can damage the engine parts that move.

Cover the spark plug hole while the spark plug is removed.

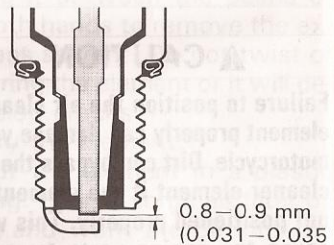
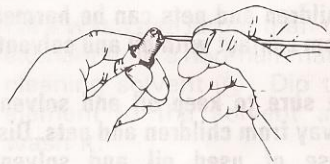

To maintain a hot, strong spark keep the plug free from carbon. Remove carbon deposits from the plug with a wire or pin, and adjust the gap to 0.8 – 0.9 mm (0.031 – 0.035 in) for good ignition. Use a thickness (feeler) gauge to check the gap.

ENGINE OIL

Engine life depends on oil amount and quality. Daily engine oil level checks and periodic changes are two of the most important maintenance items to be performed.

Engine Oil Level Check

Engine oil level

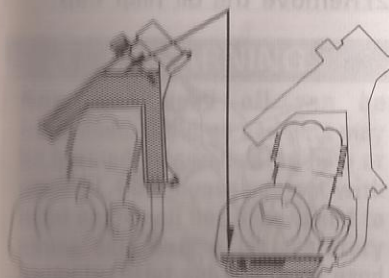

When the engine is operating

When the engine is not operating

The engine oil is pumped up to the engine oil tank while the engine is running. The engine oil tank of this motorcycle is built in an upper part of its frame. When the engine is not operating, most of the oil gathers in its crankcase. To check the engine oil level, follow the procedure below.

(1) Place the motorcycle on the side stand.

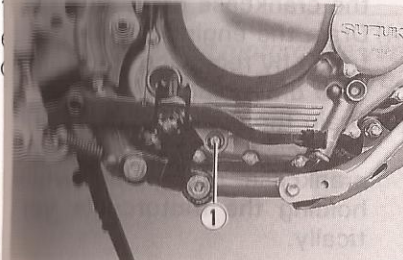

(2) When the engine is cold, make sure that enough oil to start the engine remains in the crankcase. Loosen the oil loss check bolt (1) and see that the oil drips from the oil loss hole, then retighten the bolt. If the oil level is lower than the lower edge of the check hole while the motorcycle is in vertical position, have your Suzuki dealer or a qualified service mechanic inspect the engine for oil leaks.

NOTE: It takes about 4 hours to gather enough amount of oil to perform this check in the crankcase. When the engine is warm and you are sure enough oil to start the engine remains in the engine component, checking the oil loss is not necessary.

- (3) Start the engine and allow it to idle for three minutes.
- (4) Stop the engine and wait one minute.
- (5) Remove the oil filler cap. The engine oil dipstick (2) comes out together with the oil filler cap.

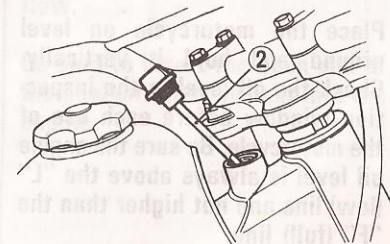

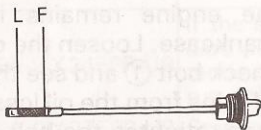

- (6) Wipe the oil from the dipstick with a clean rag.
- (7) Holding the motorcycle vertically, reinsert the dipstick until the threads touch filler neck, but do not screw the cap in.
- (8) Draw out the dipstick and check the oil level. The level found on the dipstick should be between "L" (Low) and "F" (Full) lines. If the oil level is below the "L" line, add fresh oil from the filler hole until the oil level reaches to "F" line.

⚠ CAUTION

Operating the motorcycle with too little or too much oil can damage your engine.

Place the motorcycle on level ground and hold it vertically. Check the oil level in the inspection window before each use of the motorcycle. Be sure the engine oil level is always above the "L" (low) line and not higher than the "F" (full) line.

Engine Oil and Filter Change

Change the engine oil and oil filter at the scheduled times. The engine should always be warm when the oil is changed so the oil will drain easily. The procedure is as follows:

- (1) Place the motorcycle on the side stand.
- (2) Remove the oil filler cap.

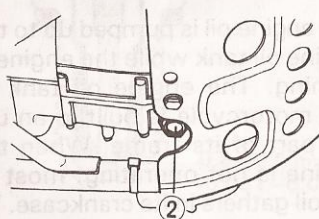
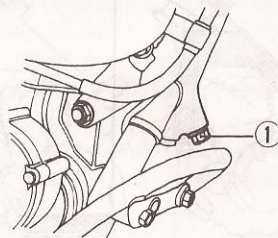

- (3) Place drain pans under the frame tube drain plug (1) and the crankcase drain plug (2).
- (4) Drain the engine oil from the frame by removing the frame tube drain plug.
- (5) Drain the engine oil from the crankcase by removing the crankcase drain plug while holding the motorcycle vertically.

⚠ WARNING

Engine oil and exhaust pipes can be hot enough to burn you.

Wait until the oil drain plug and exhaust pipes are cool enough to touch with bare hands before draining oil.

⚠ WARNING

New and used oil can be hazardous. Children and pets may be harmed by swallowing new or used oil. Continuous contact with used engine oil has been found to cause skin cancer in laboratory animals. Brief contact with used oil may irritate skin.

Keep new and used oil and used oil filter away from children and pets. To minimize your exposure to used oil, wear a long-sleeve shirt and moisture-proof gloves (such as dishwashing gloves) when changing oil. If oil contacts your skin, wash thoroughly with soap and water. Launder any clothing or rags if wet with oil. Recycle or properly dispose of used oil and oil filters.

NOTE: Hold the motorcycle vertically while draining the engine oil to drain all oil.

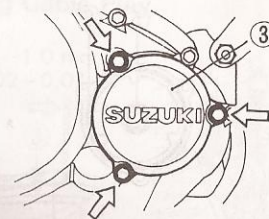

- (6) Remove the three nuts holding the filter cover (3) in place.

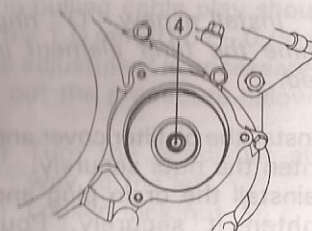

- (7) Remove the filter cover and pull out the oil filter element (4). Insert the new filter in the same position.

⚠ CAUTION

Failure to insert the new element correctly can damage the motorcycle. No oil flow will result if the element is inserted backwards. Engine damage will occur from no oil flow.

Be sure to insert the open end of the new oil filter element into the engine.

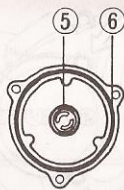

- (8) Check to be sure that the filter spring ⑤ and the cap "O" ring ⑥ are installed correctly.

NOTE: Install a new "O" ring each time the filter element is replaced.

- (9) Reinstall the oil filter cover and tighten the nuts securely.
 (10) Reinstall the drain plug and tighten it securely. Pour about 1 900 ml (2.0 US qt) of the specified oil in the filler hole. (See FUEL AND ENGINE OIL RECOMMENDATION section.)

⚠ CAUTION

Engine damage may occur if you use oil that does not meet Suzuki's specifications.

Be sure to use the oil specified in the FUEL AND ENGINE OIL RECOMMENDATION section.

- (11) Start the engine (while the motorcycle is outside on level ground) and allow it to idle for a few minutes.
 (12) Check the oil level according to oil level check procedure.

CARBURETOR

Undisturbed carburetion is the basis of the performance you ought to expect of your engine. The carburetor is factoryset for the best performance. Do not attempt to alter its setting. There are two items of adjustment, however, under your care: engine idle speed and throttle cable play.

Engine Idle Speed Adjustment

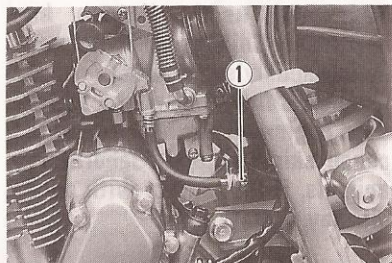

To adjust the idle speed:

- (1) Start the engine and warm it up by running 2 000 r/min for 10 minutes in summer (where ambient temperature is 30°C (86°F) or thereabout) or for 20 minutes in winter (where ambient temperature is down to -5°C (23°F) or thereabout).
 (2) Turn the throttle stop screw ① in or out so that the engine idles at 1 400 - 1 600 r/min.

Throttle Cable Adjustment

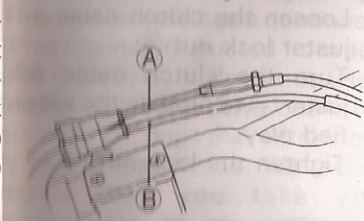

This motorcycle has a twin throttle cable system. Cable A is for pulling cable and cable B is for returning. To adjust the cable play, adjust the returning cable first and then adjust the pulling cable.

Returning Cable Play

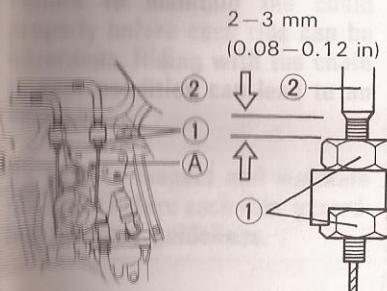

The returning cable adjuster should have 2-3 mm (0.08-0.12 in) of clearance as shown in the illustration.

- If the adjustment is necessary, carry out the procedure below:
 (1) Loosen two lock nuts ①.
 (2) Move adjuster ② to obtain the clearance of 2-3 mm (0.08-0.12 in).
 (3) Tighten two lock nuts ① securely.

Pulling Cable Play

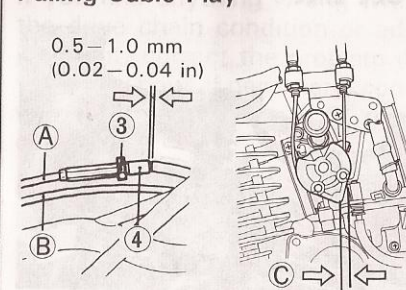

The pulling cable play should be 0.5-1.0 mm (0.02-0.04 in). If the adjustment is necessary, carry out the procedure below:

- (1) Turn the handlebar all the way to the left.
 (2) Loosen lock nut ③.
 (3) Turn adjuster ④ to obtain a cable play of 0.5-1.0 mm (0.02-0.04 in).
 (4) Tighten lock nut ③ securely.
 (5) Make sure that the clearance of ⑤ is less than 1.0 mm (0.04 in) when the throttle is fully opened.

⚠ WARNING

Incorrect throttle cable adjustment can be hazardous. Inadequate outer cable play can raise engine speed when you turn the handlebars to the right or left. This could lead to loss of rider control.

Check that engine idle speed is not increased due to handlebars movement.

FUEL LINE

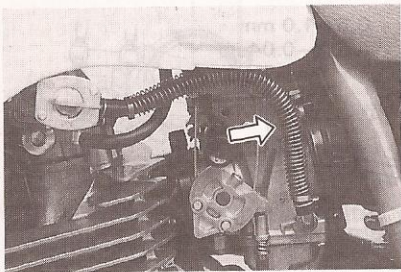

Replace the fuel line every four years, even if it looks OK. Damage from aging may not always be visible.

ENGLISH

CLUTCH ADJUSTMENT

Clutch cable play should be 10 – 15 mm (0.4 – 0.6 in) measured at the clutch lever holder. Adjust the clutch cable play according to the following procedure:

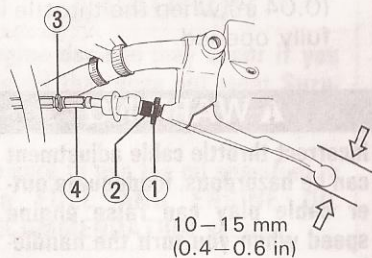

Minor Adjustment

- (1) Loosen the clutch cable adjuster lock nut ①.
- (2) Turn the clutch cable adjuster ② to provide the specified play.
- (3) Tighten the lock nut ①.

Major Adjustment

- (1) Loosen the clutch cable adjuster lock nut ③.
- (2) Turn the clutch cable adjuster ④ to provide the specified play.
- (3) Tighten the lock nut ③.

DRIVE CHAIN

This motorcycle has a continuous drive chain constructed from special materials. It does not use a master link. The drive chain has special "O" rings that permanently seal grease inside. We recommend that you take your motorcycle to an authorized Suzuki dealer if the drive chain needs replacing. The condition and adjustment of the drive chain should be checked before each use of the motorcycle. Always follow the guidelines below for inspecting and servicing the chain.

⚠ WARNING

Failure to maintain the chain properly before each ride can be hazardous. Riding with the chain in poor condition can lead to an accident.

Be sure to inspect and maintain the chain before each ride, according to these guidelines.

Inspecting the Drive Chain

When inspecting the chain, look for the following:

- Loose pins
- Damaged rollers
- Dry or rusted links
- Kinked or binding links
- Excessive wear
- Improper chain adjustment

If you find anything wrong with the drive chain condition or adjustment, correct the problem if you know how. If necessary, consult your authorized Suzuki dealer.

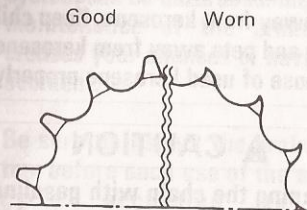

Damage to the drive chain means that the sprockets may also be damaged. Inspect the sprockets for the following:

- (1) Excessively worn teeth
- (2) Broken or damaged teeth
- (3) Loose sprocket mounting nut(s)

If you find any of these problems with your sprocket, consult your Suzuki dealer.

Drive Chain Cleaning and Oiling

Clean and oil the chain as follows:

- (1) Wash the chain with kerosene. Kerosene will lubricate and clean the chain.

⚠ WARNING

Kerosene can be hazardous. Kerosene is flammable. Children or pets may be harmed from contact with kerosene.

Keep flames and smoking materials away from kerosene. Keep children and pets away from kerosene. Dispose of used kerosene properly.

⚠ CAUTION

Cleaning the chain with gasoline, trichlene or other commercial cleaning solvents is not recommended as these fluids can damage the "O" rings and ruin the chain.

Use only kerosene to clean the drive chain.



- (2) Allow the chain dry, then lubricate the links with Suzuki chain lube. If you cannot use Suzuki chain lube, use a motor oil (SAE 20W/50).

⚠ CAUTION

Some drive chain lubricants contain solvents and additives which could damage the "O" rings in your chain.

Use Suzuki chain lube or an equivalent that is specifically intended for use on "O" ring chains.

Drive Chain Adjustment

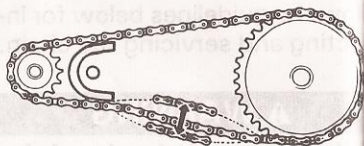

25–40 mm
(1.0–1.6 in)

Inspect the drive chain slack before each use of the motorcycle. The drive chain should be adjusted for 25–40 mm (1.0–1.6 in) of slack, as shown.

⚠ WARNING

Failure to inspect the drive chain slack before each use of the motorcycle could be hazardous. Too much chain slack could cause the chain to come off the sprockets resulting in an accident or serious damage to the motorcycle.

Inspect the drive chain slack before each use.

To adjust the drive chain, follow the procedure below:

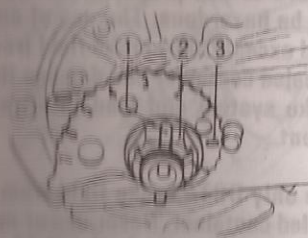

- (1) Place the motorcycle on the side stand.
- (2) Remove the cotter pin ① and loosen the axle nut ②.
- (3) Turn the right and left adjuster ③ until the chain has 25–40 mm (1.0–1.6 in) of slack halfway between the engine sprocket and rear sprocket.
- (4) At the same time that the chain is being adjusted, the rear sprocket must be kept in perfect alignment with the front sprocket. To assist you in performing this procedure, there are reference marks on the adjuster and each chain adjuster which are to be aligned with each other and to be used as a reference from one side to the other.
- (5) Tighten the axle nut ② securely. Replace the cotter pin with a new one.
- (6) Recheck the chain slack after tightening and readjust if necessary.

BRAKES

This motorcycle has front and rear disc brakes.

⚠ WARNING

Failure to properly inspect and maintain your motorcycle's brake system can be hazardous. Improper maintenance of the brakes increases your chances of having an accident.

Be sure to inspect the brake system before each use of the motorcycle according to the **INSPECTION BEFORE RIDING** section. Always maintain or replace your brakes, brake hose, and brake fluid according to the **MAINTENANCE SCHEDULE**.

NOTE: Operating in mud, water, sand or other extreme conditions can cause accelerated brake wear. If you operate your motorcycle under these conditions, the brakes must be inspected more often than recommended in the MAINTENANCE SCHEDULE.

Brake Fluid

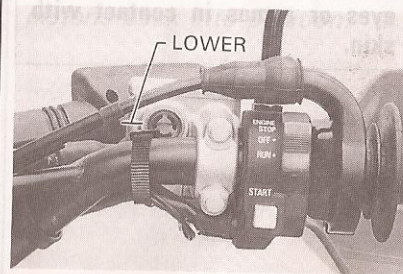

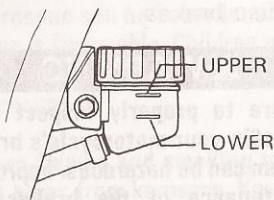

Be sure to check the brake fluid level in both the front and rear brake fluid reservoirs. If the level in either reservoir is below the lower mark, add DOT4 brake fluid. Make sure you do not fill the rear reservoir above the upper level mark.

▲ WARNING

Brake fluid can be hazardous to humans and pets. Brake fluid is harmful or fatal if swallowed, and harmful if it comes in contact with your skin or eyes.

Keep brake fluid away from children. Call your doctor immediately if brake fluid is swallowed, and induce vomiting. Flush eyes or skin with water if brake fluid gets in eyes or comes in contact with skin.

▲ WARNING

Failure to use proper brake fluid can be hazardous. The use of any fluid except DOT4 brake fluid from a sealed container can damage the brake system and lead to an accident.

Use only DOT4 brake fluid from a sealed container. Never use or mix different types of brake fluid.

▲ WARNING

Failure to keep the brake fluid reservoir full can be hazardous. The brakes may not work correctly without the proper amount of brake fluid. This could lead to an accident.

Inspect the brake fluid level before each use. If there is frequent loss of fluid, take your motorcycle to a Suzuki dealer for inspection.

▲ CAUTION

Spilled brake fluid can damage painted surface and plastic parts.

Be careful not to spill any fluid when filling the brake fluid reservoir. Wipe spilled fluid up immediately.

Brake Pads

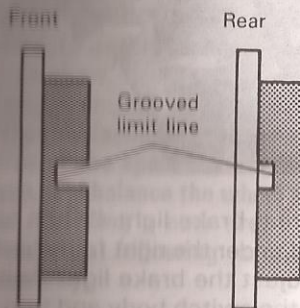
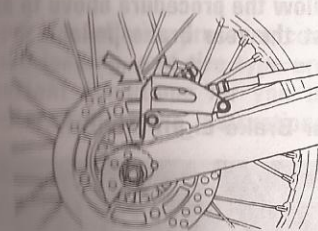
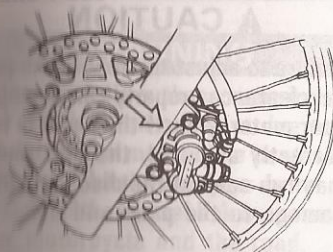

Inspect the front and rear brake pads to see if they are worn down to the grooved wear limit line. If a pad is worn to the grooved wear limit line, it must be replaced with a new one. After replacing either the front or rear brake pads, the brake lever or pedal must be pumped several times. This will extend the pads to their proper position.

▲ WARNING

Failure to maintain the brake pads and replace them when recommended can be hazardous. Riding with worn brake pads, or pads in the front or rear that are unevenly worn will increase your chances of having an accident.

If you need to replace brake pads, have your Suzuki dealer do the work. Inspect and maintain the brake pads as recommend.

▲ WARNING

Failure to extend the brake pads after repair or replacement can be hazardous. Inadequate braking performance could result in an accident.

Before riding "pump" the brake lever/pedal several times to extend the pads and restore the proper lever/pedal stroke and firm feel.

NOTE: Do not squeeze/depress the brake lever/pedal when the pads are not in their positions. It is difficult to push the pistons back into position.

Rear Brake Adjustment

The rear brake pedal must be adjusted to set the clearance between the pedal and the footrest. Adjust the brake pedal as follows:

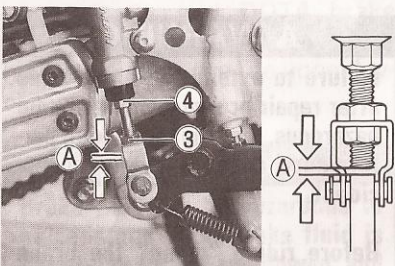
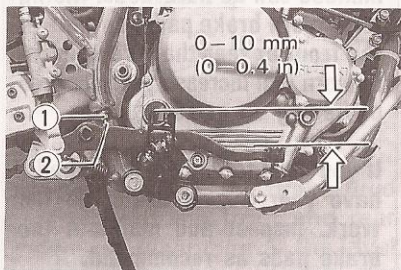

- (1) Loosen lock nut ①.
- (2) Adjust the brake pedal height by turning adjuster ② to locate the pedal 0–10 mm (0–0.4 in) below the top face of the footrest.
- (3) Tighten lock nut ①.
- (4) Loosen lock nut ③.
- (5) Adjust the brake pedal play by turning adjuster ④ to have the play of 5–15 mm (0.2–0.6 in) at the front end of the pedal.
- (6) Check that the clearance of A is at least 0.5 mm (0.02 in).
- (7) Tighten lock nut ③.

⚠ CAUTION

Failure to adjust the rear brake pedal clearance properly can damage your motorcycle. If the pedal is incorrectly adjusted, the disc pads may rub against the disc, causing damage to the pads and disc.

Follow the procedure above to adjust the rear brake pedal.

Rear Brake Light Switch

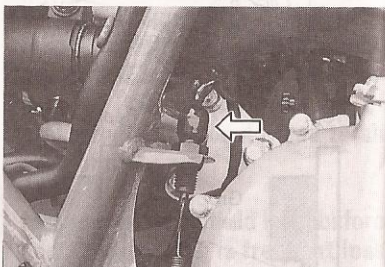

The rear brake light switch is located under the right frame cover. To adjust the brake light switch, hold the switch body and turn the adjuster so that the brake light will come on just before a pressure rise is felt when the brake pedal is depressed.

TIRES

⚠ WARNING

Failure to follow these warnings may result in an accident due to tire failure or motorcycle control difficulty. The tires on your motorcycle form the crucial link between your motorcycle and the road.

Proper tire inflation pressure, condition, loading, and tire type are important conditions for you to monitor. Follow the instructions below:

- Check tire pressure and condition each time before you ride.
- Do not overload your tires.
- Replace tires when tread is worn to specified limit, or if tires show visual evidence of damage, such as cracks or cuts.
- When replacing tires, use only tires of the specified size and type, and balance the wheel after installing a new tire.
- Read the following section carefully.

Tire Pressure and Loading

Proper tire pressure and proper tire loading are important factors. Overloading your tires can lead to tire failure and loss of motorcycle control.

Check tire pressure each time before you ride, according to the table below. Tire pressure should only be checked and adjusted before riding since riding will heat up the tires and lead to higher inflation pressure readings.

Under-inflated tires make smooth cornering difficult and can result in rapid wear. Over-inflated tires have a smaller amount of tire in contact with the road, which can contribute to skidding and loss of control.

| | FRONT | REAR |
|-------------|--|--|
| SOLO RIDING | 1.50 kg/cm ² 150 kPa 22 psi | 1.50 kg/cm ² 150 kPa 22 psi |
| DUAL RIDING | 1.50 kg/cm ² 150 kPa 22 psi | 1.75 kg/cm ² 175 kPa 25 psi |

Tire Condition and Type

Tire condition and tire type affect motorcycle performance. Cuts or cracks in the tires can lead to tire failure and loss of motorcycle control. Worn tires are susceptible to puncture failures and subsequent loss of motorcycle control. Tire wear also affects the tire profile, changing motorcycle handling characteristics.

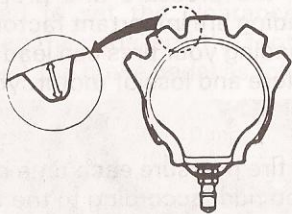

Check tire condition each time before you ride. Replace tires if tires show visual evidence of damage such as cracks or cuts, or if tread depth is less than 4.0 mm (0.16 in).

NOTE: These wear limits will be reached before the wear bars molded into the tire make contact with the road.

When you replace a tire, be sure to replace it with a tire of the size and type listed below. If you use a different size or type of tire, motorcycle handling may be adversely affected, possibly resulting in loss of motorcycle control.

| | |
|-------|---------------|
| FRONT | 80/100-21 51P |
| REAR | 110/90-18 61P |

Be sure to balance the wheel after repairing a puncture or replacing the tire. Proper wheel balance is important to avoid variable wheel-to-road contact and to avoid uneven tire wear.

⚠ WARNING

Improperly repairing or replacing tires is hazardous. Improperly repaired or balanced tires can cause uneven tire wear or poor riding stability.

We recommend that you have an authorized Suzuki dealer or qualified mechanic perform these procedures because proper tools and experience are required.

⚠ WARNING

Using tires that have been installed incorrectly can be hazardous. The motorcycle may have unusual handling if the tires are installed incorrectly.

The tires are intended to rotate in a specified direction, as indicated by the arrows on the sidewall of each tire. Install tires so they rotate in the proper direction.

SPOKE NIPPLE TIGHTNESS

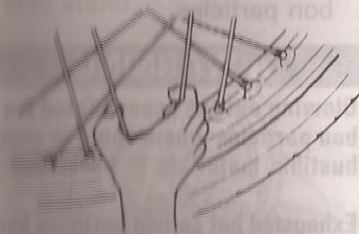

Check the tension to verify the tightness of the spoke nipples. The tension of the spokes can be checked by squeezing the spokes with your fingers. If a spoke nipple is loose, the spoke will bend more than the others. The tension can also be checked by hitting the spokes with a small metal bar. If the spoke nipple is loose, its sound will be dull.

To tighten the spoke nipples properly, tighten them equally to the specified torque. Loose and overtightened spoke nipples may cause unequal spoke tension and may result in wheel rim distortion. Contact your Suzuki dealer for this service.

SIDE STAND/IGNITION INTERLOCK SYSTEM

Check the side stand/ignition interlock system for proper operation as follows:

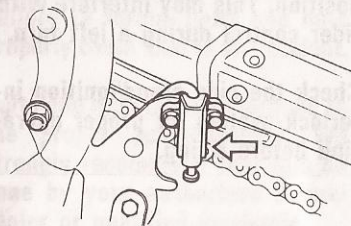

- (1) Sit on the motorcycle in the normal riding position, with the side stand up.
- (2) Shift into first gear, hold the clutch in, and start the engine.
- (3) While continuing to hold the clutch in, move the side stand to the down position.

If the engine stops running when the side stand is moved to the down position, then the side stand/ignition interlock system is working properly. If the engine continues to run with the side stand down and the transmission in gear, then the side stand/ignition interlock system is not working properly. Have your motorcycle inspected by an authorized Suzuki dealer or some other qualified service mechanic.

⚠ WARNING

If the side stand/ignition interlock system is not working properly, it is possible to ride the motorcycle with the side stand in the down position. This may interfere with rider control during a left turn.

Check the side stand/ignition interlock system for proper operation before riding.

SPARK ARRESTER

The muffler has a spark arrester which must be periodically cleaned to maintain good efficiency. At the intervals shown the maintenance chart, clean the spark arrester as follows.

⚠ WARNING

A hot muffler can burn you.

Wait until the muffler cools to avoid burns.

- 1) Shift into neutral.

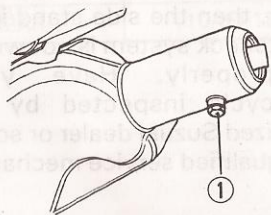

- 2) Remove the drain bolt ①.

- 3) Start the engine and rev it to blow out the accumulated carbon particles.

⚠ WARNING

Blowing out the accumulated carbon particles where there is combustible materials is hazardous.

Exhausted hot carbon particles can start a fire.

Clean the spark arrester in an open area away from combustible materials.

- 4) Reinstall the drain bolt.

⚠ WARNING

Running the engine with loosen drain bolts or without drain bolt can be hazardous.

Hot carbon particles can blow out if there are no drain bolts. This can cause a fire.

Be sure to tighten the drain bolt securely.

FRONT WHEEL REMOVAL

- 1) Place the motorcycle on the side stand.

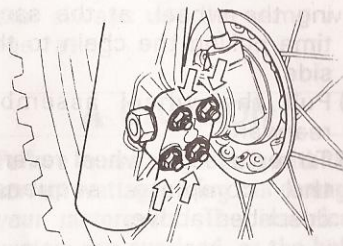

- 2) Loosen the four axle holder bolts.
- 3) Lift the front end of the motorcycle up and place a jack or a block under the engine or chassis tubes.

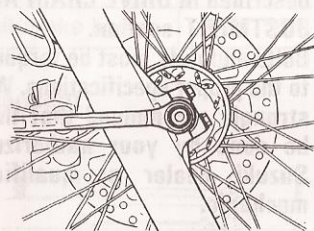

- 4) Turn the axle shaft counter-clockwise and draw it out.

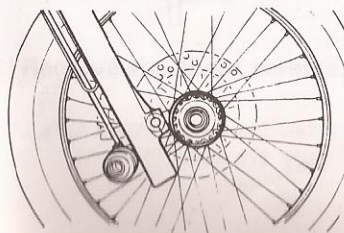

- 5) Slide the front wheel forward.
- 6) To reinstall the wheel assembly reverse the sequence as described above.

⚠ WARNING

Failure to torque bolts and nuts properly could lead to an accident.

Bolts and nuts must be torqued to the proper specifications. We strongly recommend that this be done by your authorized Suzuki dealer or qualified mechanic.

Front axle shaft tightening torque:
50–80 N·m (5.0–8.0 kg·m,
36.0–58.0 lb·ft)

Axle holder bolt tightening torque:
6–8 N·m (0.6–0.8 kg·m,
4.5–6.0 lb·ft)

REAR WHEEL REMOVAL

1) Place the motorcycle on the side stand.

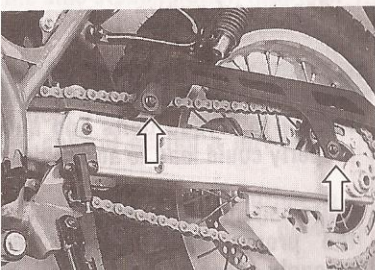

2) Remove the two chain guard screws and then remove the chain guard.

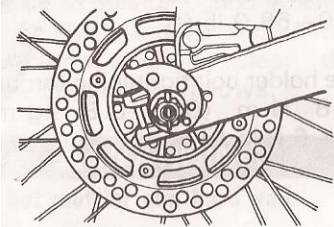

3) Remove the cotter pin and axle nut.

4) Lift the rear wheel up and place a jack or a block under the engine or chassis tubes.

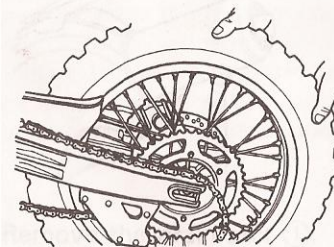

- (5) Draw out the axle shaft.
- (6) With the wheel moved forward, remove the chain from the sprocket by slowly rotating the wheel, at the same time pulling the chain to the side.
- (7) Pull the wheel assembly rearward.
- (8) To replace the wheel reverse the complete sequence described above.

▲ WARNING

Failure to adjust the chain and failure to torque bolts and nuts properly could lead to an accident.

- After re-installing the rear wheel, adjust the chain as described in **DRIVE CHAIN ADJUSTMENT** section.
- Bolts and nuts must be torqued to the proper specifications. We strongly recommend that this be done by your authorized Suzuki dealer or qualified mechanic.

Rear axle nut tightening torque:
85–115 N·m (8.5–11.5 kg·m,
61.5–83.0 lb·ft)

LIGHT BULB REPLACEMENT

The wattage rating of each bulb is shown in the following chart. When replacing a burned out bulb, always use the same wattage rating.

▲ CAUTION

Failure to use a light bulb with the correct wattage rating can damage your motorcycle. The electrical system can overload, or the bulb may burn out sooner.

Use only the light bulbs shown in the chart as replacement bulbs.

| | |
|-------------------|------------|
| Headlight | 12V 60/55W |
| Turn signal light | 12V 21W |
| Tail/Brake light | 12V 5/21W |

Headlight

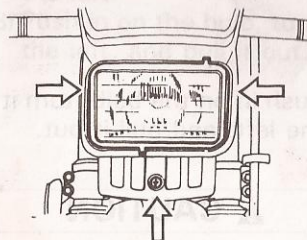

(1) Remove the three screws.

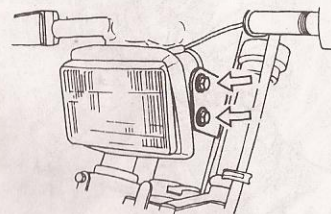

(2) Remove the four bolts.

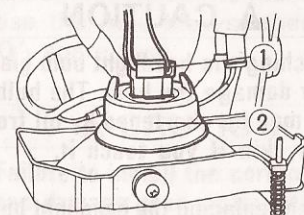

(3) Disconnect socket ① from the headlight and remove the rubber cap ②.

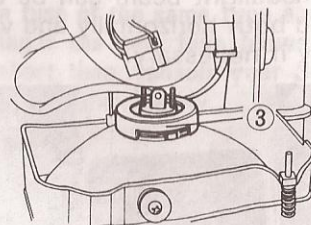

(4) Push the ring ③ and turn it clockwise.

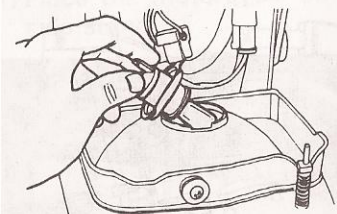

5) Remove the bulb.

▲ CAUTION

Touching the headlight bulb glass may damage the bulb. The bulb's life may be shortened by oil from your skin if you touch it.

When replacing the headlight bulb, be careful not to touch the glass. Grasp the new bulb with a clean cloth.

Headlight Beam Adjustment

The headlight beam can be adjusted both horizontally and vertically if necessary.

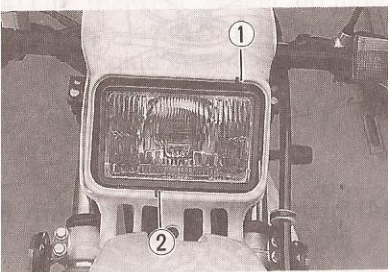

To adjust the beam horizontally: Turn the adjuster ① clockwise or counterclockwise.

To adjust the beam vertically: Turn the adjuster ② clockwise or counterclockwise.

Turn Signal Light

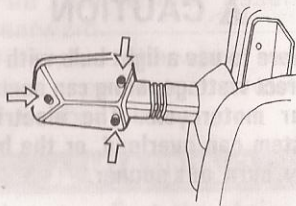

(1) Remove the screws and take off the lens.

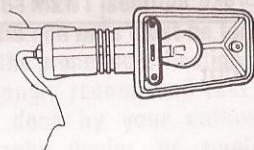

(2) Push in on the bulb, turn it to the left, and pull it out.

▲ CAUTION

Overtightening the screws may cause the lens to crack.

Tighten the lens screws only until they are snug.

Tail/Brake Light

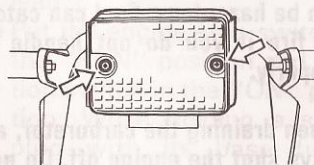

(1) Loosen the screws and remove the lens.

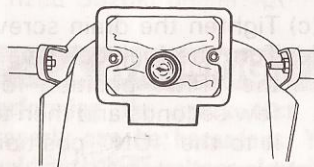

(2) Remove the socket, turn it to the left.
 (3) Push in on the bulb, turn it to the left, and pull it out.

FUSE

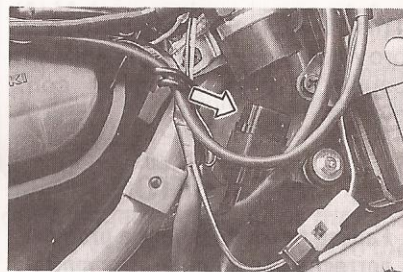

If there is any electrical system failure, first check the fuse. In the case the fuse blows, there is a 20A spare fuse.

▲ CAUTION

Failure to install the correct fuse can damage your motorcycle. Installing a fuse of incorrect rating or using aluminum foil or wire instead of a fuse may seriously damage the electrical system.

Always replace a blown fuse with a fuse of the same type and rating. If the new fuse blows in a short time, consult your Suzuki dealer immediately.

TROUBLESHOOTING

This troubleshooting guide is provided to help you find the cause of some common complaints.

CAUTION

Failure to troubleshoot a problem correctly can damage your motorcycle. Improper repairs or adjustments may damage the motorcycle instead of fixing it. Such damage may not be covered under warranty.

If you are not sure about the proper action, consult your Suzuki dealer about the problem.

COMPLAINT: Engine is hard to start or does not start at all.

Something is probably wrong with the fuel system or ignition system.

Fuel System Check

- Make sure there is enough fuel in the fuel tank.
- Make sure there is enough fuel reaching the carburetor from the fuelcock.
 - Turn the fuelcock lever to the "ON" position.
 - Loosen the drain screw located under the carburetor. Drain the fuel from the carburetor into a container.

WARNING

Draining fuel from the carburetor can be hazardous. Fuel can catch on fire if you do not handle it properly.

When draining the carburetor, always shut the engine off. Do not smoke, and never drain or refuel in an area where there are open flames or sparks. Do not spill the fuel or you may create a fire hazard. Dispose of drained fuel properly.

- Tighten the drain screw.
- Turn the fuelcock lever to the "PRI" position for a few seconds and then turn it to the "ON" position.
- Loosen the drain screw and check that the carburetor is filled back up with fuel.
- If fuel is reaching the carburetor, ignition system should be checked next.

AFLO DEL TORNILLO DRENAJE DEBIDO CARBURADOR

Ignition System Check

- Remove the spark plug and reattach it to the spark plug lead.
- Put the engine stop switch in the "RUN" position and ignition switch in the "ON" position. While holding a spark plug with its base firmly against the engine, push the electric starter button. If the ignition system is operating properly, a blue spark should jump across the spark plug gap. If there is no spark, take your machine to your authorized Suzuki dealer.

WARNING

Performing the spark test improperly can be hazardous. You could get a high voltage electrical shock if you are not familiar with this procedure.

Do not perform this check if you are not familiar with the procedure. Do not point the spark plug near the spark plug hole during this test. Do not do this test if you have a heart condition or wear a pacemaker.

COMPLAINT: Engine Stalls

- Make sure there is enough fuel in the fuel tank.
- Check to see that the spark plug is not fouled. Remove the plug and clean it. Replace it, if necessary.
- Make sure the fuelcock is not clogged. Also check that the air vent hose connected to the fuel tank is not clogged.
- Check the engine idle speed. If necessary, adjust it using a tachometer. The correct idle speed is 1 400 — 1 600 r/min.

STORAGE PROCEDURE

Your motorcycle is to be left unattended for an extended period of time, it needs special servicing requiring appropriate materials, equipment and skill. For this reason, Suzuki recommends that you just this maintenance work to your Suzuki dealer. If you wish to service the machine for storage yourself, follow the general guidelines below:

MOTORCYCLE

Place the motorcycle on the side stand and thoroughly clean the entire motorcycle.

FUEL

- Fill the fuel tank to the top with fuel mixed with the amount of gasoline stabilizer recommended by the stabilizer manufacturer.
- Drain the carburetor or run the engine for a few minutes until the stabilized gasoline fills the carburetor.

▲ WARNING

Draining the fuel tank can be hazardous. Fuel can catch on fire if you do not handle it properly.

When draining the fuel tank, always shut the engine off. Do not smoke, and never drain fuel in an area where there are open flames or sparks. Keep pets and children away from fuel, and dispose of fuel properly.

ENGINE

- Pour one tablespoon of motor oil into each spark plug hole. Reinstall the spark plugs and crank the engine a few times.
- Drain the engine oil thoroughly and refill the crankcase with fresh engine oil all the way up to the filler hole.
- Cover the air cleaner intake and the muffler outlet with oily rags to prevent humidity from entering.

BATTERY

- Remove the battery from the motorcycle.
- Clean the outside of the battery with a mild soap and remove corrosion from the terminals and wiring harness.
- Store the battery in a room above freezing.

TIRES

Inflate tires to the normal pressure.

EXTERNAL

- Spray all vinyl and rubber parts with rubber protectant.
- Spray unpainted surface with rust preventative.
- Coat painted surfaces with car wax.

MAINTENANCE DURING STORAGE

Once a month, recharge the battery. The standard charging rate is 0.7 A x 5 hours.

PROCEDURE FOR RETURNING STORAGE

- Clean the entire motorcycle.
- Remove the oily rags from the air cleaner intake and muffler outlet.
- Drain all the transmission oil. Fill the engine with fresh oil as outlined in this manual.
- Drain all the engine oil. Install a new oil filter and fill the engine with fresh oil as outlined in this manual.
- Remove the spark plug. Turn the engine a few times. Reinstall the spark plug.
- Reinstall the battery.
- Make sure that the motorcycle is properly lubricated.
- Perform the INSPECTION BEFORE RIDING as listed in this manual.
- Start the motorcycle as outlined in this manual.

APPEARANCE CARE

CORROSION PREVENTION

It is important to take good care of your motorcycle to protect it from corrosion. Listed below are instructions on how to maintain your motorcycle to prevent corrosion and keep it looking new for years to come.

Important Information About Corrosion

Common cause of corrosion

- (1) Accumulation of road salt, dirt moisture, or chemicals in hard-to-reach areas.
- (2) Chipping, scratches, and any damage to treated or painted metal surfaces resulting from minor accidents or impacts from stones and gravel.

Road salt, dust-control chemicals, sea air, industrial pollution, and high humidity will all contribute to, or accelerate, corrosion.

The above signifies the necessity of keeping your motorcycle as clean and dry as possible. It is equally important to repair any damage to the paint or protective coatings as soon as possible.

How to Help Prevent Corrosion

1) Wash your motorcycle frequently

The best way to preserve the finish on your motorcycle and to help avoid corrosion is to keep it clean with frequent washing. Wash your motorcycle at least once a month. Keep your motorcycle as dry and clean as possible.

2) Remove foreign material deposits

Foreign material such as road salt, chemicals, road oil or tar, tree sap, bird droppings and industrial fall-out may damage the finish of your motorcycle if it is left on painted surfaces. Remove these types of deposits as quickly as possible. If these deposits are difficult to wash off, an additional cleaner may be required. Be sure that any cleaner you use is not harmful to painted surfaces and is specifically intended for your purposes. Follow the manufacturer's directions when using these special cleaners.

3) Repair finish damage

Carefully examine your motorcycle for damage to the painted surfaces. Should you find any chips or scratches in the paint, touch them up immediately to prevent corrosion from starting. If the chips or scratches have gone through to the bare metal, have a Suzuki dealer make the repair.

(4) Store your motorcycle in a dry, well-ventilated area

Do not park your motorcycle in a damp, poorly ventilated area. If you often wash your motorcycle in the garage or if you frequently park it inside when wet, your garage may be damp. The high humidity in the garage may cause or accelerate corrosion. A wet motorcycle may corrode even in a heated garage if the ventilation is poor.

(5) Cover your motorcycle

Years of exposure to mid-day sun can cause the colors in paint, plastic parts, and instrument faces to fade. Covering your motorcycle with a high-quality, "breathable" motorcycle cover can help protect the finish from the harmful UV rays in sunlight, and can reduce the amount of dust and air pollution reaching the surface. Your Suzuki dealer can help you select the right cover for your motorcycle.

MOTORCYCLE CLEANING

Washing the Motorcycle

When washing the motorcycle, follow the instructions below:

- (1) Remove dirt and mud from the motorcycle with running water. You may use a soft sponge or brush. Do not use hard materials which can scratch the paint.
- (2) Wash the entire motorcycle with a mild detergent or car wash soap using a sponge or soft cloth. The sponge or cloth should be frequently soaked in the soap solution.

NOTE: Avoid spraying or allowing water to flow over the following places:

- Ignition switch
- Spark plug
- Fuel tank cap
- Carburetor
- Brake master cylinders

- (3) Once the dirt has been completely removed, rinse off the detergent with running water.
- (4) After rinsing, wipe off the motorcycle with a wet chamois or cloth and allow it to dry in the shade.
- (5) Check carefully for damage to painted surfaces. If there is any damage, obtain "touch-up" paint and "touch-up" the damage following the procedure below:

- (a) Clean all damaged spots and allow them to dry.

- (b) Stir the paint and "touch-up" the damaged spots lightly with a small brush.
- (c) Allow the paint to dry completely.

Waxing the Motorcycle

After washing the motorcycle, waxing and polishing are recommended to further protect and beautify the paint.

- Only use waxes and polishes of good quality.
- When using waxes and polishes, observe the precautions specified by the manufacturers.

INSPECTION AFTER CLEANING

For extended life of your motorcycle, lubricate according to "GENERAL LUBRICATION" section.

⚠ WARNING

Operating the motorcycle with wet brakes can be hazardous. Wet brakes may not provide as much stopping power as dry brakes. This could lead to an accident.

Test your brakes after washing the motorcycle, while riding at slow speed. If necessary, apply brakes several times to let friction dry out the lining.

Follow the procedures in the "INSPECTION BEFORE RIDING" section to check your motorcycle for any problems that may have arisen during your last ride.

CONSUMER INFORMATION

EMISSION CONTROL WARRANTY

Suzuki Motor Corporation warrants to the ultimate purchaser and each subsequent purchaser that this vehicle is designed, built, and equipped so as to conform at the time of sale with all U.S. emission standards applicable at the time of manufacture, and that it is free from defects in materials and workmanship which would cause it not to meet these standards within its useful life. Useful life is defined for each class of motorcycle as 5 years or the corresponding number of kilometers (miles) shown in the chart below, whichever occurs first.

| Vehicle class | Engine displacement | Useful Life Distance |
|---------------|---------------------|---------------------------|
| Class I | 50 to 169 cc | 12000 km (7456 miles) |
| Class II | 170 to 279 cc | 18000 km (11185 miles) |
| Class III | 280 cc and over | 30000 km (18641 miles) |

Failure, other than those resulting from defects in material or workmanship, which arise solely as a result of owner abuse and/or lack of proper maintenance are not covered by the warranty.

REPORTING SAFETY DEFECTS

If you believe that your vehicle has a defect which could cause a crash or could cause injury or death, you should immediately inform the National Highway Traffic Safety Administration (NHTSA) in addition to notifying American Suzuki Motor Corp.

If NHTSA receives similar complaints, it may open an investigation, and if it finds that a safety defect exists in a group of vehicles, it may order a recall and remedy campaign. However, NHTSA cannot become involved in individual problems between you, your dealer, American Suzuki Motor Corp.

To contact NHTSA, you may either call the Auto Safety Hotline toll-free at 1-800-424-9393 (or 366-0123 in Washington, D.C. area) or write to: NHTSA, U.S. Department of Transportation, Washington, D.C. 20590. You can also obtain other information about motor vehicle safety from the Hotline.

To contact American Suzuki, owners in the continental United States can call toll-free 1-800-444-5077, or write to: American Suzuki Motor Corporation Motorcycle Customer Service P.O. Box 1100, Brea, CA 92622-1100.

For owners outside the continental United States, please refer to the distributor's address listed on your Warranty Information brochure.

TAMPERING WITH NOISE CONTROL SYSTEM PROHIBITED

Federal law prohibits the following acts or the causing thereof;

- (1) The removal or rendering inoperative by any person other than for purposes of maintenance, repair, or replacement, of any device or element of designed incorporated into any new vehicle for the purpose of noise control prior to its sale or delivery to the ultimate purchaser or while it is in use, or
- (2) The use of the vehicle after such device or element of designed has been removed or rendered inoperative by any person.

Among those acts presumed to constitute tampering are the acts listed below:

- Removing or puncturing the muffler, baffles, header pipes, or any other component which conducts exhaust gases.
- Replacing the exhaust system or muffler with a system or muffler not marked with the same model specific code as the code listed on the Motorcycle Noise Emission Control Information label, and certified to appropriate EPA noise standards.

- Removing or puncturing the air cleaner case, air cleaner cover, baffles, or any other component which conducts intake air.

Whenever replacing parts on your motorcycle, Suzuki recommends that you use genuine Suzuki replacement parts or their equivalent.



The frame number (1) is stamped on the starting head tube as shown in the illustration. The engine serial number (2) is stamped on the right side of the crankcase assembly.

Write down the serial numbers here for your future reference.

Frame No. _____

Engine No. _____

SERIAL NUMBER LOCATION

You need to know the frame and engine serial numbers to get title documents for your motorcycle. You also need these numbers to help your dealer when you order parts.

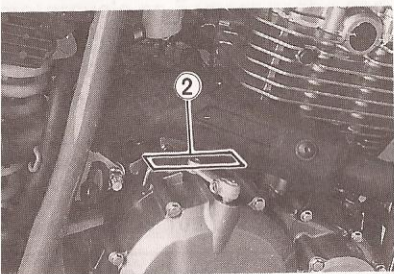
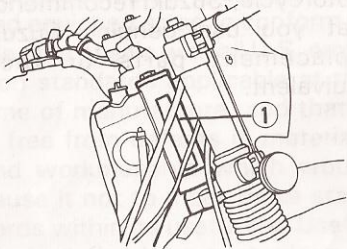

The frame number ① is stamped on the steering head tube as shown in the illustration. The engine serial number ② is stamped on the right side of the crankcase assembly.

Write down the serial numbers here for your future reference.

Frame No.:

Engine No.:

— MEMO —

SPECIFICATIONS

DIMENSIONS AND DRY MASS

| | |
|------------------|--------------------|
| Overall length | 2 235 mm (88.0 in) |
| Overall width | 885 mm (34.8 in) |
| Overall height | 1 245 mm (49.0 in) |
| Wheelbase | 1 445 mm (56.9 in) |
| Ground clearance | 290 mm (11.4 in) |
| Seat height | 890 mm (35.0 in) |
| Dry mass | 130 kg (287 lbs) |

ENGINE

| | |
|-----------------------|--|
| Type | Four-stroke, air-cooled with SACS, OHC |
| Valve clearance, IN | 0.05—0.10 mm (0.002—0.004 in) |
| EX | 0.17—0.22 mm (0.007—0.009 in) |
| Number of cylinder | 1 |
| Bore | 73.0 mm (2.874 in) |
| Stroke | 59.6 mm (2.346 in) |
| Cylinder displacement | 249 cm ³ (15.2 cu. in) |
| Compression ratio | 10.0 : 1 |
| Carburetor | MIKUNI BST33SS, single |
| Air cleaner | Polyurethane foam element |
| Starting system | Electric starter motor |
| Lubrication system | Dry sump |

TRANSMISSION

| | |
|-------------------------|--|
| Clutch | Wet multi-plate type |
| Transmission | 6-speed constant mesh |
| Gearshift pattern | 1-down, 5-up |
| Primary reduction ratio | 3.200 (64/20) |
| Gear ratios, Low | 2.416 (29/12) |
| 2nd | 1.733 (26/15) |
| 3rd | 1.333 (24/18) |
| 4th | 1.111 (20/18) |
| 5th | 0.952 (20/21) |
| Top | 0.826 (19/23) |
| Final reduction ratio | 3.000 (42/14) |
| Drive chain | TAKASAGO RK520SO or DAIDO DID520VC.5, 108 links |

CHASSIS

| | |
|------------------|--|
| Front suspension | Telescopic, coil spring, oil dampened, spring preload fully adjustable, compression damping force 8-way adjustable |
| Rear suspension | Link type suspension, coil spring, gas/oil dampened, spring preload fully adjustable, compression damping adjustable |
| Caster | 61° |
| Trail | 123 mm (4.8 in) |
| Steering angle | 45° (right & left) |
| Turning radius | 2.3 m (7.5 ft) |
| Front brake | Disc |
| Rear brake | Disc |
| Front tire size | 80/100-21 51P |
| Rear tire size | 110/90-18 61P |

ELECTRICAL

| | |
|-----------------------------|--|
| Ignition type | Electronic ignition |
| Ignition timing | 15° B.T.D.C. at 1 500 r/min and 27° B.T.D.C. above 4 400 r/min NGK DPR9EA-9 or NIPPONDENSO |
| Spark plug | X27EPR-U9 |
| Battery | 12V 21.6 kC(6 Ah)/10HR |
| Generator | Three-phase A.C. generator |
| Fuse | 20A |
| Headlight | 12V 60/55W |
| Turn signal light | 12V 21W |
| Tail/Brake light | 12V 5/21W |
| License plate light | 12V 5W |
| Speedometer light | 12V 1.7W (x2 pcs.) |
| Tachometer light | 12V 3W |
| Neutral indicator light | 12V 1.7W |
| High beam indicator light | 12V 1.7W |
| Turn signal indicator light | 12V 1.7W |

CAPACITIES

| | |
|------------------------------|--|
| Fuel tank, including reserve | 9.0 L (2.4 US gal) |
| Reserve | 8.0 L (2.1 US gal) |
| Engine oil, oil change | 2.0 L (0.5 US gal) |
| with filter change | 1 700 ml (1.8 US gal) 1 900 ml (2.0 US gal) |